

PROJECT MANUAL FOR

New Beaufort County PK-3 School

Beaufort County Schools
Washington, North Carolina

Hite associates

ARCHITECTURE / PLANNING / TECHNOLOGY

2600 Meridian Drive / Greenville, NC 27834 / tel 252.757.0333 / www.hiteassoc.com

CIVIL ENGINEERING CONSULTANT: Rivers and Associates, Inc.

107 East 2nd Street, Greenville, NC 27858, (252) 752-4135

STRUCTURAL ENGINEERING CONSULTANT: Queen Engineering & Design, P.A.

5530 Munford Road, Raleigh, NC 27612, (919) 420-0480

MECHANICAL / ELECTRICAL ENGINEERING CONSULTANT: Engineering Source of NC, P.A.

102-A2 Regency Blvd., Greenville, NC 27859, (252) 439-0338

Volume I

July 2024

NOTICE TO BIDDERS

INSTRUCTIONS TO BIDDERS

SUPPLEMENTARY INSTRUCTIONS TO BIDDERS

FORM OF PROPOSAL

HUB INSTRUCTIONS AND FORMS FOR BIDS

FORM OF CONTRACT

PERFORMANCE BOND

LABOR AND MATERIAL PAYMENT BOND

AHERA INSPECTION REPORTS

DIVISION 1 - GENERAL REQUIREMENTS

- Section 01010 - General Conditions
 - 01012 - Supplementary Conditions
 - 01013 – Additional Supplementary Conditions
 - 01040 - General Requirements & Construction Schedule
 - 01041 - Sales Tax Form
 - 01050 - Special Conditions for Utilities Construction
 - 01055 - Alternates
 - 01056 - Allowances
 - 01060 - Geotechnical Subsurface Report
 - 01062 - Testing Laboratory Services
 - 01065 - Project Sign
 - 01068 - Index of Industry Standards Abbreviations

DIVISION 2 - SITE WORK

- Section 02070 – Selective Demolition
 - 02110 - Site Clearing
 - 02200 - Earthwork
 - 02210 – Trenching and Backfilling for Utilities
 - 02281 - Termite Control
 - 02400 - Erosion Control
 - 02401 - Soil Erosion and Sedimentation Control Plan Narrative
 - 02402 – Stormwater Narrative and Calculations
 - 02403 – Stormwater Narrative and Nutrient Calculations
 - 02480 - Landscape Work
 - 02485 – Synthetic Grass Playground Safety Surface
 - 02500 - Concrete Curb, Gutter, and Sidewalk
 - 02513 - Asphalt Concrete Paving
 - 02713 - Water Mains
 - 02730 – Gravity Sanitary Sewer System
 - 02736 - Storm Sewer System
 - 02827 – Ornamental Picket Security Fencing
 - 02830 - Chain Link Fencing and Gates
 - 02835 – Concrete Segmental Retaining Wall System

DIVISION 3 - CONCRETE

- Section 03100 - Concrete Formwork
03200 - Cast-In-Place Concrete
03250 - Concrete Finishes
03300 - Concrete Reinforcement
03450 – Architectural Precast Concrete Units

DIVISION 4 - MASONRY

- Section 04200 - Unit Masonry
04340 - Reinforced Unit Masonry
Brick Technical Notes 7B; Water Resistance – Construction and Workmanship

DIVISION 5 - METALS

- Section 05120 - Structural Steel
05210 - Steel Joists and Joist Girders
05311 - Steel Roof Deck
05313 - Steel Floor Deck
05400 - Cold-Formed Metal Stud Framing System
05500 - Metal Fabrications
05800 - Expansion Controls

DIVISION 6 - WOOD AND PLASTICS

- Section 06100 - Rough Carpentry
06400 - Architectural Woodwork

DIVISION 7 - THERMAL AND MOISTURE PROTECTION

- Section 07200 - Building Insulation
07218 – Sprayed-On Acoustical Insulation
07220 - Roof Insulation
07415 – Aluminum Composite Panels
07600 - Flashing and Sheetmetal
07610 - Metal Roofing
07900 - Joint Sealers

DIVISION 8 - DOORS AND WINDOWS

- Section 08100 - Hollow Metal Doors and Frames
08200 - Wood Doors
08210 – FRP Doors and Frames
08255 – Rolling Counter Shutter Curtains
08410 - Aluminum Swing Entrances
08418 - Aluminum Storefront Systems
08452 – Insulated Translucent Fiberglass Panel Wall System
08700 - Finish Hardware
08800 - Glass and Glazing
08870 – Security Glazing Films
08954 – Architectural Louvers

DIVISION 9 - FINISHES

Section 09250 - Gypsum Drywall Systems
09260 - Gypsum Drywall Framing
09300 - Tile
09400 – Terrazzo
09500 – Acoustical Panels
09510 - Acoustical Ceilings
09600 – Interior Stonework
09624 – Special Athletic Flooring
09650 - Resilient Flooring
09671 – Resinous Flooring
09781 – Carpeting
09860 – Intumescent Fireproofing
09900 - Painting

DIVISION 10 - SPECIALTIES

Section 10100 - Markerboards and Tackboards
10280 - Flagpoles
10440 - Specialty Signs and Building Equipment
10445 – Storage Shelving
10500 – Metal Lockers
10520 - Fire Extinguishers, Cabinets, and Accessories
10535 - Pre-Engineered Walkway Covers, Canopies and Awnings
10655 – Folding Partitions
10800 - Toilet Accessories
10850 – Miscellaneous Specialties
10900 - Plastic Toilet Partitions

DIVISION 11 - EQUIPMENT

Section 11132 – Projection Screens
11140 – Stage Curtains
11150 – Basketball Goals and Athletic Equipment
11200 – Kitchen Equipment
11450 - Residential Kitchen Equipment
11780 – Video Display Monitors and Mounting Equipment

DIVISION 12 - FURNISHINGS

(NOT USED)

DIVISION 13 - SPECIAL CONSTRUCTION

Section 13900 - Wet Pipe Sprinkler Systems with Storage Tank

DIVISION 14 - CONVEYING SYSTEMS

(NOT USED)

DIVISION 15 - MECHANICAL

Section 15000 - General Provisions for Plumbing and HVAC
15050 - Basic Mechanical Materials and Methods
15060 - Hanger and Supports

- 15100 - Valves
- 15150 - Excavating and Backfilling
- 15170 - Motors
- 15190 - Mechanical Identification

DIVISION 15A - PLUMBING

- Section 15200 - Water Supply Systems
- 15250 - DWV Piping Systems
- 15400 - Fixture & Equipment
- 15405 - Plumbing Specialties
- 15430 - Domestic Water Heaters
- 15475 - Natural Gas Piping System

DIVISION 15B - HEATING, VENTILATION, & AIR CONDITIONING

- Section 15500 - Mechanical Insulation
- 15682 - Air Cooled Liquid Chiller
- 15735 - Condensate Piping System
- 15740 - Hydronic Piping
- 15740A - Hydronic Piping Systems
- 15745 - Water Treatment Systems
- 15750 - Pumps, Air Control and Accessories
- 15800 - Air Distribution and Accessories
- 15825 - Fire Dampers
- 15830 - Louvers
- 15857 - Fan Coil Equipment
- 15860 - Exhaust Fans
- 15870 - Air Filters
- 15963 - Control Valves & Actuator Systems
- 15965 - Variable Frequency Drives
- 15975 - Electrical Work
- 15980 - Systems Test & Balance
- 15981 - Air Balance Report

DIVISION 16 - ELECTRICAL

- Section 16000 - General Provision
- 16100 - Raceways and Conduits
- 16140 - Conductors and Wiring Devices
- 16400 - Service and Distribution
- 16460 - Dry-Type Transformers
- 16500 - Lighting System
- 16800 - Fire Alarm System Expansion
- 16825 - Multi Purpose Room Sound System
- 16899 - Fire Alarm System Inspection and Testing Form
- 16900 - Tests and Project Close-Out

DIVISION 17 INTERGRATED COMMUNICATIONS

- Section 17000 - General Provisions
- 17200 - Data Cabling Systems
- 17250 - Backbone Cabling
- 17300 - Bogen Nyquist E700 Series IP Based Communication System
- 17700 - Security Systems

17900 - Tests, Commissioning and Project Closeout

END OF TABLE OF CONTENTS

NOTICE TO BIDDERS

Sealed proposals from selected bidders will be received by Beaufort County Schools Board of Education, at the office of the Superintendent, 321 Smaw Road, Washington, NC 27889 on, Wednesday, November 13, 2024, AT 3:00 pm for the furnishing of labor, material and equipment entering into the construction of the **New Beaufort PK-3 School**. Bids will immediately thereafter be publicly opened and read. Bidders are welcome to attend the bid opening, but bidder presence is not required and no weight or other consideration toward any award decision will be given to any bidder's attendance or absence at the bid opening. Bids shall be marked "SEALED BID", addressed to the attention of Dr. Dr. Matthew Cheeseman, Superintendent, Beaufort County Schools, and shall include the Name, Address, and License Number of the Bidder, and the type proposal enclosed.

Bids will be received as follows:

1. Single Prime Contract (All Work)

Complete plans, specifications and contract documents are available on the Hite Associates website, www.hiteassoc.com, and will be open for inspection in the office of the Architect, Hite Associates, 2600 Meridian Drive, Greenville, North Carolina, 27834, during normal office hours, and may be obtained for purchase by calling Speedyblue Reprographics at (252) 758-1616, print@speedyblue.com.

There will be a Pre-Bid Conference on Wednesday, October 23 at 3:00 PM, at Beaufort County Schools, 321 Smaw Road, Washington, NC 27889.

In accordance with federal regulations, the contractor must provide certification that it will not and has not used federal appropriated funds to pay any person or organization for influencing or attempting to influence an officer or employee of any agency, a member of Congress, an officer or employee of Congress, or an employee of a member of Congress in connection with obtaining any federal contract, grant or any other award covered by this amendment. Each must also disclose any lobbying with non-federal funds that takes place in connection with obtaining any federal award.

All Contractors are hereby notified that they must have proper license under the State laws governing their respective trades.

General Contractors are notified that Chapter 87, Article I, General Statutes of North Carolina, will be observed in receiving bids and awarding the General Contract. General Contractors submitting bids on this project must have proper license classification.

Each proposal shall be accompanied by a cash deposit or a certified check drawn on some bank or trust company insured by the Federal Deposit Insurance Corporation, of an amount equal to not less than five

NOTICE TO BIDDERS

percent (5%) of the proposal, or in lieu thereof, a bidder may offer a bid bond of five percent (5%) of the bid executed by a surety company licensed under the laws of North Carolina to execute such bonds, conditioned that the surety will, upon demand forthwith make payment to the obligee upon said bond if the bidder fails to execute the contract in accordance with the bid bond. Said deposit shall be retained by the Owner as liquidated damages in event of failure of the successful bidder to execute the contract within ten days after the award or to give satisfactory surety as required by law. In determining the value of the bid bond, additive or deductive alternates shall be considered as they are accepted by the Owner.

A Performance Bond and a Labor and Materials Payment Bond will be required for one hundred percent (100%) of the contract price.

Payment will be made on the basis of ninety-five percent (95%) of monthly estimates and final payment made upon completion and acceptance of work.

No Bid may be withdrawn after the scheduled closing time for the receipt of bids, and shall remain valid and good for a period of 90 days after the bid date.

The Owner reserves the right to reject any or all bids and to waive informalities.

SIGNED: Dr. Matthew Cheeseman, Superintendent
Beaufort County Schools
321 Smaw Road
Washington, NC 27889

DESIGNER: HITE ASSOCIATES, P.C.
2600 Meridian Drive
Greenville, NC 27834

GO TO NEXT PAGE

AIA[®] Document A701[®] – 2018

Instructions to Bidders

for the following Project:
(Name, location, and detailed description)

Beaufort Intermediate School

THE OWNER:

(Name, legal status, address, and other information)

Beaufort County Schools
321 Smaw Road
Washington, NC 27889

THE ARCHITECT:

(Name, legal status, address, and other information)

Hite Associates, P.C.
2600 Meridian Drive
Greenville, NC 27834
Telephone Number: 252-757-0333

TABLE OF ARTICLES

- 1 DEFINITIONS**
- 2 BIDDER'S REPRESENTATIONS**
- 3 BIDDING DOCUMENTS**
- 4 BIDDING PROCEDURES**
- 5 CONSIDERATION OF BIDS**
- 6 POST-BID INFORMATION**
- 7 PERFORMANCE BOND AND PAYMENT BOND**
- 8 ENUMERATION OF THE PROPOSED CONTRACT DOCUMENTS**

ADDITIONS AND DELETIONS:

The author of this document has added information needed for its completion. The author may also have revised the text of the original AIA standard form. An *Additions and Deletions Report* that notes added information as well as revisions to the standard form text is available from the author and should be reviewed. A vertical line in the left margin of this document indicates where the author has added necessary information and where the author has added to or deleted from the original AIA text.

This document has important legal consequences. Consultation with an attorney is encouraged with respect to its completion or modification.

FEDERAL, STATE, AND LOCAL LAWS MAY IMPOSE REQUIREMENTS ON PUBLIC PROCUREMENT CONTRACTS. CONSULT LOCAL AUTHORITIES OR AN ATTORNEY TO VERIFY REQUIREMENTS APPLICABLE TO THIS PROCUREMENT BEFORE COMPLETING THIS FORM.

It is intended that AIA Document G612™–2017, Owner's Instructions to the Architect, Parts A and B will be completed prior to using this document.

ARTICLE 1 DEFINITIONS

§ 1.1 Bidding Documents include the Bidding Requirements and the Proposed Contract Documents. The Bidding Requirements consist of the advertisement or invitation to bid, Instructions to Bidders, supplementary instructions to bidders, the bid form, and any other bidding forms. The Proposed Contract Documents consist of the unexecuted form of Agreement between the Owner and Contractor and that Agreement's Exhibits, Conditions of the Contract (General, Supplementary and other Conditions), Drawings, Specifications, all Addenda, and all other documents enumerated in Article 8 of these Instructions.

§ 1.2 Definitions set forth in the General Conditions of the Contract for Construction, or in other Proposed Contract Documents apply to the Bidding Documents.

§ 1.3 Addenda are written or graphic instruments issued by the Architect, which, by additions, deletions, clarifications, or corrections, modify or interpret the Bidding Documents.

§ 1.4 A Bid is a complete and properly executed proposal to do the Work for the sums stipulated therein, submitted in accordance with the Bidding Documents.

§ 1.5 The Base Bid is the sum stated in the Bid for which the Bidder offers to perform the Work described in the Bidding Documents, to which Work may be added or deleted by sums stated in Alternate Bids.

§ 1.6 An Alternate Bid (or Alternate) is an amount stated in the Bid to be added to or deducted from, or that does not change, the Base Bid if the corresponding change in the Work, as described in the Bidding Documents, is accepted.

§ 1.7 A Unit Price is an amount stated in the Bid as a price per unit of measurement for materials, equipment, or services, or a portion of the Work, as described in the Bidding Documents.

§ 1.8 A Bidder is a person or entity who submits a Bid and who meets the requirements set forth in the Bidding Documents.

§ 1.9 A Sub-bidder is a person or entity who submits a bid to a Bidder for materials, equipment, or labor for a portion of the Work.

ARTICLE 2 BIDDER'S REPRESENTATIONS

§ 2.1 By submitting a Bid, the Bidder represents that:

- .1 the Bidder has read and understands the Bidding Documents;
- .2 the Bidder understands how the Bidding Documents relate to other portions of the Project, if any, being bid concurrently or presently under construction;
- .3 the Bid complies with the Bidding Documents;
- .4 the Bidder has visited the site, become familiar with local conditions under which the Work is to be performed, and has correlated the Bidder's observations with the requirements of the Proposed Contract Documents;
- .5 the Bid is based upon the materials, equipment, and systems required by the Bidding Documents without exception; and
- .6 the Bidder has read and understands the provisions for liquidated damages, if any, set forth in the form of Agreement between the Owner and Contractor.

ARTICLE 3 BIDDING DOCUMENTS

§ 3.1 Distribution

§ 3.1.1 Bidders shall obtain complete Bidding Documents, as indicated below, from the issuing office designated in the advertisement or invitation to bid, for the deposit sum, if any, stated therein.

(Indicate how, such as by email, website, host site/platform, paper copy, or other method Bidders shall obtain Bidding Documents.)

§ 3.1.2 Any required deposit shall be refunded to Bidders who submit a bona fide Bid and return the paper Bidding Documents in good condition within ten days after receipt of Bids. The cost to replace missing or damaged paper documents will be deducted from the deposit. A Bidder receiving a Contract award may retain the paper Bidding Documents, and the Bidder's deposit will be refunded.

§ 3.1.3 Bidding Documents will not be issued directly to Sub-bidders unless specifically offered in the advertisement or invitation to bid, or in supplementary instructions to bidders.

§ 3.1.4 Bidders shall use complete Bidding Documents in preparing Bids. Neither the Owner nor Architect assumes responsibility for errors or misinterpretations resulting from the use of incomplete Bidding Documents.

§ 3.1.5 The Bidding Documents will be available for the sole purpose of obtaining Bids on the Work. No license or grant of use is conferred by distribution of the Bidding Documents.

§ 3.2 Modification or Interpretation of Bidding Documents

§ 3.2.1 The Bidder shall carefully study the Bidding Documents, shall examine the site and local conditions, and shall notify the Architect of errors, inconsistencies, or ambiguities discovered and request clarification or interpretation pursuant to Section 3.2.2.

§ 3.2.2 Requests for clarification or interpretation of the Bidding Documents shall be submitted by the Bidder in writing and shall be received by the Architect at prior to the date for receipt of Bids.
(Indicate how, such as by email, website, host site/platform, paper copy, or other method Bidders shall submit requests for clarification and interpretation.)

§ 3.2.3 Modifications and interpretations of the Bidding Documents shall be made by Addendum. Modifications and interpretations of the Bidding Documents made in any other manner shall not be binding, and Bidders shall not rely upon them.

§ 3.3 Substitutions

§ 3.3.1 The materials, products, and equipment described in the Bidding Documents establish a standard of required function, dimension, appearance, and quality to be met by any proposed substitution.

§ 3.3.2 Substitution Process

§ 3.3.2.1 Written requests for substitutions shall be received by the Architect at least ten days prior to the date for receipt of Bids. Requests shall be submitted in the same manner as that established for submitting clarifications and interpretations in Section 3.2.2.

§ 3.3.2.2 Bidders shall submit substitution requests on a Substitution Request Form if one is provided in the Bidding Documents.

§ 3.3.2.3 If a Substitution Request Form is not provided, requests shall include (1) the name of the material or equipment specified in the Bidding Documents; (2) the reason for the requested substitution; (3) a complete description of the proposed substitution including the name of the material or equipment proposed as the substitute, performance and test data, and relevant drawings; and (4) any other information necessary for an evaluation. The request shall include a statement setting forth changes in other materials, equipment, or other portions of the Work, including changes in the work of other contracts or the impact on any Project Certifications (such as LEED), that will result from incorporation of the proposed substitution.

§ 3.3.3 The burden of proof of the merit of the proposed substitution is upon the proposer. The Architect's decision of approval or disapproval of a proposed substitution shall be final.

§ 3.3.4 If the Architect approves a proposed substitution prior to receipt of Bids, such approval shall be set forth in an Addendum. Approvals made in any other manner shall not be binding, and Bidders shall not rely upon them.

§ 3.3.5 No substitutions will be considered after the Contract award unless specifically provided for in the Contract Documents.

§ 3.4 Addenda

§ 3.4.1 Addenda will be transmitted to Bidders known by the issuing office to have received complete Bidding Documents.

(Indicate how, such as by email, website, host site/platform, paper copy, or other method Addenda will be transmitted.)

§ 3.4.2 Addenda will be available where Bidding Documents are on file.

§ 3.4.3 Addenda will be issued prior to the date for receipt of Bids, except an Addendum withdrawing the request for Bids or one which includes postponement of the date for receipt of Bids.

§ 3.4.4 Prior to submitting a Bid, each Bidder shall ascertain that the Bidder has received all Addenda issued, and the Bidder shall acknowledge their receipt in the Bid.

ARTICLE 4 BIDDING PROCEDURES

§ 4.1 Preparation of Bids

§ 4.1.1 Bids shall be submitted on the forms included with or identified in the Bidding Documents.

§ 4.1.2 All blanks on the bid form shall be legibly executed. Paper bid forms shall be executed in a non-erasable medium.

§ 4.1.3 Sums shall be expressed in both words and numbers, unless noted otherwise on the bid form. In case of discrepancy, the amount entered in words shall govern.

§ 4.1.4 Edits to entries made on paper bid forms must be initialed by the signer of the Bid.

§ 4.1.5 All requested Alternates shall be bid. If no change in the Base Bid is required, enter "No Change" or as required by the bid form.

§ 4.1.6 Where two or more Bids for designated portions of the Work have been requested, the Bidder may, without forfeiture of the bid security, state the Bidder's refusal to accept award of less than the combination of Bids stipulated by the Bidder. The Bidder shall neither make additional stipulations on the bid form nor qualify the Bid in any other manner.

§ 4.1.7 Each copy of the Bid shall state the legal name and legal status of the Bidder. As part of the documentation submitted with the Bid, the Bidder shall provide evidence of its legal authority to perform the Work in the jurisdiction where the Project is located. Each copy of the Bid shall be signed by the person or persons legally authorized to bind the Bidder to a contract. A Bid by a corporation shall further name the state of incorporation and have the corporate seal affixed. A Bid submitted by an agent shall have a current power of attorney attached, certifying the agent's authority to bind the Bidder.

§ 4.1.8 A Bidder shall incur all costs associated with the preparation of its Bid.

§ 4.2 Bid Security

§ 4.2.1 Each Bid shall be accompanied by the following bid security:

(Insert the form and amount of bid security.)

§ 4.2.2 The Bidder pledges to enter into a Contract with the Owner on the terms stated in the Bid and shall, if required, furnish bonds covering the faithful performance of the Contract and payment of all obligations arising thereunder. Should the Bidder refuse to enter into such Contract or fail to furnish such bonds if required, the amount

of the bid security shall be forfeited to the Owner as liquidated damages, not as a penalty. In the event the Owner fails to comply with Section 6.2, the amount of the bid security shall not be forfeited to the Owner.

§ 4.2.3 If a surety bond is required as bid security, it shall be written on AIA Document A310™, Bid Bond, unless otherwise provided in the Bidding Documents. The attorney-in-fact who executes the bond on behalf of the surety shall affix to the bond a certified and current copy of an acceptable power of attorney. The Bidder shall provide surety bonds from a company or companies lawfully authorized to issue surety bonds in the jurisdiction where the Project is located.

§ 4.2.4 The Owner will have the right to retain the bid security of Bidders to whom an award is being considered until (a) the Contract has been executed and bonds, if required, have been furnished; (b) the specified time has elapsed so that Bids may be withdrawn; or (c) all Bids have been rejected. However, if no Contract has been awarded or a Bidder has not been notified of the acceptance of its Bid, a Bidder may, beginning days after the opening of Bids, withdraw its Bid and request the return of its bid security.

§ 4.3 Submission of Bids

§ 4.3.1 A Bidder shall submit its Bid as indicated below:

(Indicate how, such as by website, host site/platform, paper copy, or other method Bidders shall submit their Bid.)

§ 4.3.2 Paper copies of the Bid, the bid security, and any other documents required to be submitted with the Bid shall be enclosed in a sealed opaque envelope. The envelope shall be addressed to the party receiving the Bids and shall be identified with the Project name, the Bidder's name and address, and, if applicable, the designated portion of the Work for which the Bid is submitted. If the Bid is sent by mail, the sealed envelope shall be enclosed in a separate mailing envelope with the notation "SEALED BID ENCLOSED" on the face thereof.

§ 4.3.3 Bids shall be submitted by the date and time and at the place indicated in the invitation to bid. Bids submitted after the date and time for receipt of Bids, or at an incorrect place, will not be accepted.

§ 4.3.4 The Bidder shall assume full responsibility for timely delivery at the location designated for receipt of Bids.

§ 4.3.5 A Bid submitted by any method other than as provided in this Section 4.3 will not be accepted.

§ 4.4 Modification or Withdrawal of Bid

§ 4.4.1 Prior to the date and time designated for receipt of Bids, a Bidder may submit a new Bid to replace a Bid previously submitted, or withdraw its Bid entirely, by notice to the party designated to receive the Bids. Such notice shall be received and duly recorded by the receiving party on or before the date and time set for receipt of Bids. The receiving party shall verify that replaced or withdrawn Bids are removed from the other submitted Bids and not considered. Notice of submission of a replacement Bid or withdrawal of a Bid shall be worded so as not to reveal the amount of the original Bid.

§ 4.4.2 Withdrawn Bids may be resubmitted up to the date and time designated for the receipt of Bids in the same format as that established in Section 4.3, provided they fully conform with these Instructions to Bidders. Bid security shall be in an amount sufficient for the Bid as resubmitted.

§ 4.4.3 After the date and time designated for receipt of Bids, a Bidder who discovers that it made a clerical error in its Bid shall notify the Architect of such error within two days, or pursuant to a timeframe specified by the law of the jurisdiction where the Project is located, requesting withdrawal of its Bid. Upon providing evidence of such error to the reasonable satisfaction of the Architect, the Bid shall be withdrawn and not resubmitted. If a Bid is withdrawn pursuant to this Section 4.4.3, the bid security will be attended to as follows:

(State the terms and conditions, such as Bid rank, for returning or retaining the bid security.)

ARTICLE 5 CONSIDERATION OF BIDS

§ 5.1 Opening of Bids

If stipulated in an advertisement or invitation to bid, or when otherwise required by law, Bids properly identified and received within the specified time limits will be publicly opened and read aloud. A summary of the Bids may be made available to Bidders.

§ 5.2 Rejection of Bids

Unless otherwise prohibited by law, the Owner shall have the right to reject any or all Bids.

§ 5.3 Acceptance of Bid (Award)

§ 5.3.1 It is the intent of the Owner to award a Contract to the lowest responsive and responsible Bidder, provided the Bid has been submitted in accordance with the requirements of the Bidding Documents. Unless otherwise prohibited by law, the Owner shall have the right to waive informalities and irregularities in a Bid received and to accept the Bid which, in the Owner's judgment, is in the Owner's best interests.

§ 5.3.2 Unless otherwise prohibited by law, the Owner shall have the right to accept Alternates in any order or combination, unless otherwise specifically provided in the Bidding Documents, and to determine the lowest responsive and responsible Bidder on the basis of the sum of the Base Bid and Alternates accepted.

ARTICLE 6 POST-BID INFORMATION

§ 6.1 Contractor's Qualification Statement

Bidders to whom award of a Contract is under consideration shall submit to the Architect, upon request and within the timeframe specified by the Architect, a properly executed AIA Document A305™, Contractor's Qualification Statement, unless such a Statement has been previously required and submitted for this Bid.

§ 6.2 Owner's Financial Capability

A Bidder to whom award of a Contract is under consideration may request in writing, fourteen days prior to the expiration of the time for withdrawal of Bids, that the Owner furnish to the Bidder reasonable evidence that financial arrangements have been made to fulfill the Owner's obligations under the Contract. The Owner shall then furnish such reasonable evidence to the Bidder no later than seven days prior to the expiration of the time for withdrawal of Bids. Unless such reasonable evidence is furnished within the allotted time, the Bidder will not be required to execute the Agreement between the Owner and Contractor.

§ 6.3 Submittals

§ 6.3.1 After notification of selection for the award of the Contract, the Bidder shall, as soon as practicable or as stipulated in the Bidding Documents, submit in writing to the Owner through the Architect:

- .1 a designation of the Work to be performed with the Bidder's own forces;
- .2 names of the principal products and systems proposed for the Work and the manufacturers and suppliers of each; and
- .3 names of persons or entities (including those who are to furnish materials or equipment fabricated to a special design) proposed for the principal portions of the Work.

§ 6.3.2 The Bidder will be required to establish to the satisfaction of the Architect and Owner the reliability and responsibility of the persons or entities proposed to furnish and perform the Work described in the Bidding Documents.

§ 6.3.3 Prior to the execution of the Contract, the Architect will notify the Bidder if either the Owner or Architect, after due investigation, has reasonable objection to a person or entity proposed by the Bidder. If the Owner or Architect has reasonable objection to a proposed person or entity, the Bidder may, at the Bidder's option, withdraw the Bid or submit an acceptable substitute person or entity. The Bidder may also submit any required adjustment in the Base Bid or Alternate Bid to account for the difference in cost occasioned by such substitution. The Owner may accept the adjusted bid price or disqualify the Bidder. In the event of either withdrawal or disqualification, bid security will not be forfeited.

§ 6.3.4 Persons and entities proposed by the Bidder and to whom the Owner and Architect have made no reasonable objection must be used on the Work for which they were proposed and shall not be changed except with the written consent of the Owner and Architect.

ARTICLE 7 PERFORMANCE BOND AND PAYMENT BOND

§ 7.1 Bond Requirements

§ 7.1.1 If stipulated in the Bidding Documents, the Bidder shall furnish bonds covering the faithful performance of the Contract and payment of all obligations arising thereunder.

§ 7.1.2 If the furnishing of such bonds is stipulated in the Bidding Documents, the cost shall be included in the Bid. If the furnishing of such bonds is required after receipt of bids and before execution of the Contract, the cost of such bonds shall be added to the Bid in determining the Contract Sum.

§ 7.1.3 The Bidder shall provide surety bonds from a company or companies lawfully authorized to issue surety bonds in the jurisdiction where the Project is located.

§ 7.1.4 Unless otherwise indicated below, the Penal Sum of the Payment and Performance Bonds shall be the amount of the Contract Sum.

(If Payment or Performance Bonds are to be in an amount other than 100% of the Contract Sum, indicate the dollar amount or percentage of the Contract Sum.)

§ 7.2 Time of Delivery and Form of Bonds

§ 7.2.1 The Bidder shall deliver the required bonds to the Owner not later than three days following the date of execution of the Contract. If the Work is to commence sooner in response to a letter of intent, the Bidder shall, prior to commencement of the Work, submit evidence satisfactory to the Owner that such bonds will be furnished and delivered in accordance with this Section 7.2.1.

§ 7.2.2 Unless otherwise provided, the bonds shall be written on AIA Document A312, Performance Bond and Payment Bond.

§ 7.2.3 The bonds shall be dated on or after the date of the Contract.

§ 7.2.4 The Bidder shall require the attorney-in-fact who executes the required bonds on behalf of the surety to affix to the bond a certified and current copy of the power of attorney.

ARTICLE 8 ENUMERATION OF THE PROPOSED CONTRACT DOCUMENTS

§ 8.1 Copies of the proposed Contract Documents have been made available to the Bidder and consist of the following documents:

- .1 AIA Document A101™–2017, Standard Form of Agreement Between Owner and Contractor, unless otherwise stated below.
(Insert the complete AIA Document number, including year, and Document title.)

- .2 AIA Document A101™–2017, Exhibit A, Insurance and Bonds, unless otherwise stated below.
(Insert the complete AIA Document number, including year, and Document title.)

- .3 AIA Document A201™–2017, General Conditions of the Contract for Construction, unless otherwise stated below.
(Insert the complete AIA Document number, including year, and Document title.)

- .4 Building Information Modeling Exhibit, if completed:

.5 Drawings

Number	Title	Date
---------------	--------------	-------------

.6 Specifications

Section	Title	Date	Pages
----------------	--------------	-------------	--------------

.7 Addenda:

Number	Date	Pages
---------------	-------------	--------------

.8 Other Exhibits:

(Check all boxes that apply and include appropriate information identifying the exhibit where required.)

AIA Document E204™-2017, Sustainable Projects Exhibit, dated as indicated below:
(Insert the date of the E204-2017.)

The Sustainability Plan:

Title	Date	Pages
--------------	-------------	--------------

Supplementary and other Conditions of the Contract:

Document	Title	Date	Pages
-----------------	--------------	-------------	--------------

.9 Other documents listed below:

(List here any additional documents that are intended to form part of the Proposed Contract Documents.)

Additions and Deletions Report for AIA® Document A701® – 2018

This Additions and Deletions Report, as defined on page 1 of the associated document, reproduces below all text the author has added to the standard form AIA document in order to complete it, as well as any text the author may have added to or deleted from the original AIA text. Added text is shown underlined. Deleted text is indicated with a horizontal line through the original AIA text.

Note: This Additions and Deletions Report is provided for information purposes only and is not incorporated into or constitute any part of the associated AIA document. This Additions and Deletions Report and its associated document were generated simultaneously by AIA software at 16:11:44 ET on 09/30/2024.

PAGE 1

Beaufort Intermediate School
Beaufort County Schools
321 Smaw Road
Washington, NC 27889

...

Hite Associates, P.C.
2600 Meridian Drive
Greenville, NC 27834
Telephone Number: 252-757-0333

PAGE 3

§ 3.2.2 Requests for clarification or interpretation of the Bidding Documents shall be submitted by the Bidder in writing and shall be received by the Architect at ~~least seven days~~ prior to the date for receipt of Bids.

PAGE 4

§ 3.4.3 Addenda will be issued ~~no later than four days~~ prior to the date for receipt of Bids, except an Addendum withdrawing the request for Bids or one which includes postponement of the date for receipt of Bids.

Certification of Document's Authenticity

AIA® Document D401™ – 2003

I, , hereby certify, to the best of my knowledge, information and belief, that I created the attached final document simultaneously with its associated Additions and Deletions Report and this certification at 16:11:44 ET on 09/30/2024 under Order No. 4104247004 from AIA Contract Documents software and that in preparing the attached final document I made no changes to the original text of AIA® Document A701™ - 2018, Instructions to Bidders, other than those additions and deletions shown in the associated Additions and Deletions Report.

(Signed)

(Title)

(Dated)

SUPPLEMENTARY INSTRUCTIONS TO BIDDERS

ARTICLE 3

ADD subparagraph 3.4: In addition to obtaining Bidding Documents from the Hite Associates website, qualified bidders, subcontractors, material suppliers may obtain complete or partial sets of the Drawings Bidding Documents and specifications from SpeedyBlue Printers for the cost of printing and mailing.

ADD subparagraph 3.5: All Bidders, subcontractors, and material suppliers are to use the Hite Associates website only, for accurate and complete Bid Documents. The Owner nor the Designers will be responsible for information accessed from any other source.

ARTICLE 4

ADD: Bidders must identify the type of proposal clearly on the Bid Envelope, and include State License number thereon.

ADD: No Bid may be withdrawn after the scheduled closing time for receipt of bids, and shall remain valid and good for 90-days after the bid date.

ARTICLE 7

ADD: Furnish a Performance Bond and a Labor and Material Payment Bond in the amount of the Contract Price, covering faithful performance of contract and payment of all obligations arising thereunder on AIA Document A312.

FORM OF PROPOSAL

From: _____ Contract: GENERAL

Address: _____

To: Beaufort County Schools Date: _____

The undersigned, as bidder, hereby declares that the only person or persons interested in this proposal as principal or principals is or are named herein and that no other person than herein mentioned has any interest in this proposal or in the contract to be entered into; that this proposal is made without connection with any other person, company or parties making a bid or proposal; and that it is in all respects fair and in good faith without collusion or fraud.

The bidder further declares that he has examined the site of the work and informed himself fully in regard to all conditions pertaining to the places where the work is to be done, that he has examined the specifications for the work and the contract documents relative thereto, and has read all special provisions furnished prior to the opening of bids; that he has satisfied himself relative to the work to be performed.

The Bidder proposes and agrees if this proposal is accepted to contract with the Beaufort County Board of Education in the form of contract specified below, to furnish all necessary materials, equipment, machinery, tools, apparatus, means of transportation and labor necessary to complete the construction of the: New Beaufort PK-3 School in full in complete accordance with the plans, specifications and contract documents, to the full and entire satisfaction of the Owner and / or Architect, with a definite understanding that no money will be allowed for extra work except as set forth in the General Conditions and the Contract Documents, for the sum of:

SINGLE PRIME CONTRACT ALL WORK:

_____ Dollars(\$)

Plumbing subcontractor: _____

Mechanical subcontractor: _____

Electrical subcontractor: _____

ALTERNATES:

Should any of the alternates described in the contract documents be accepted, the amount written below shall be the amount to be added to the base bid.

ALTERNATE NO. G-1 Shall be the amount added to the Base Bid to provide 08700 finish door hardware as specified, in lieu of other, equivalent manufacturers, AND shall be the amount added to the Base Bid to provide preferred manufacturer Special-Lite FRP/aluminum doors and frames, in lieu of other equivalent manufacturers, as per Specification 08210:

(Add) _____ Dollars (\$)

ALTERNATE NO. G-2: Shall be the amount added to the Base Bid to provide preferred manufacturer ASI Accurate for toilet partitions, with vandal resistant anti-graffiti surface texture, Black Tough Texture (TT) raised profile dimple texture, in lieu of other equivalent manufacturers, as per Specification 10900.

(Add) _____ Dollars(\$)

ALTERNATE NO. G-3 Shall be the amount added to the Base Bid to provide 11200 Kitchen Equipment as specified and scheduled, in lieu of other, equivalent manufacturers:

(Add) _____ Dollars (\$)

ALTERNATE NO. G-4 Shall be the amount added to the Base Bid to provide 09650 Tarkett Luxury Vinyl Tile and Plank products as specified and scheduled, in lieu of other, equivalent manufacturers:

(Add) _____ Dollars (\$)

ALTERNATE NO. G-5 Shall be the amount added to the Base Bid to provide a terrazzo floor finish as specified in Section 09400 and scheduled, in lieu of other scheduled floor finishes:

(Add) _____ Dollars(\$)

ALTERNATE NO. P-1 Shall be the amount added to the Base Bid to provide Zurn or Sloan Regal Series flush valves, in lieu of other, equivalent manufacturers.

(Add) _____ Dollars(\$)

ALTERNATE NO. P-2 Shall be the amount added to the Base Bid to provide Moen or Delta faucets, in lieu of other, equivalent manufacturers.

(Add) _____ Dollars(\$)

ALTERNATE NO. P-3 Shall be the amount added to the Base Bid to provide Kohler plumbing fixtures, in lieu of other, equivalent manufacturers.

(Add) _____ Dollars(\$)

ALTERNATE NO. P-4 Shall be the amount added to the Base Bid to provide AO Smith Tank type and Rinnai Tankless water heaters, in lieu of other, equivalent manufacturers.

(Add) _____ Dollars(\$)

ALTERNATE NO. M-1 Shall be the amount added to the Base Bid to provide Trane Chillers and Climate Changer Air Handler equipment, in lieu of other, equivalent manufacturers.

(Add) _____ Dollars(\$)

ALTERNATE NO. M-2 Shall be the amount added to the Base Bid to provide Belimo actuators and Sq. D motor starters, in lieu of other, equivalent manufacturers.

(Add) _____ Dollars(\$)

ALTERNATE NO. M-3 Shall be the amount added to the Base Bid to provide Weil-McLain Boilers and Bell & Gosset pumps, in lieu of other, equivalent manufacturers.

(Add) _____ Dollars(\$)

ALTERNATE NO. M-4 Shall be the amount added to the Base Bid to provide Daikin or Mitsubishi ductless mini split units, in lieu of other, equivalent manufacturers.

(Add) _____ Dollars(\$)

ALTERNATE NO. E-1 Shall be the amount added to the Base Bid to provide Square D electrical equipment in lieu of other, equivalent manufacturers.

(Add) _____ Dollars (\$)

ALTERNATE NO. E-2 Shall be the amount added to the Base Bid to provide a fire alarm system manufactured by Notifier Fire Systems (to integrate with existing system) as specified, in lieu of other, equivalent manufacturers.

(Add) _____ Dollars (\$)

ALTERNATE NO. E-3 Shall be the amount added to the Base Bid to provide PA and VOIP System by Bogen Nyquest, in lieu of other, equivalent manufacturers.

(Add) _____ Dollars (\$)

UNIT PRICES:

Unit prices quoted and accepted shall apply throughout the life of the contract, except as otherwise specifically noted. Unit prices will include all costs, and shall be applied, as appropriate, to compute the total value of changes in the scope of the installed work, all in accordance with the contract documents. Unit prices listed shall include all overhead and profit costs.

ITEM #	DESCRIPTION	UNIT PRICE
1	Mass Under Cut Excavation (Disposal OFF Site)	_____ c.y. (cubic yard)
2	Foundation Under Cut Excavation (Disposal OFF Site)	_____ c.y. (cubic yard)
3	Off-Site Select Borrow Fill	_____ c.y. (cubic yard)
4	#57 or #67 Stone (Building foundations)	_____ c.y. (cubic yard)
5	CABC Stone Base (drives and parking)	_____ c.y. (cubic yard)
6	Tensar BX-1100 Geogrid	_____ s.y. (square yard)
7	4" Thick Concrete Sidewalk	_____ s.y. (square yard)
8	Conflict Box	_____ Each
9	Fire Alarm Voice/Strobe Device	_____ Each
10	Fire Alarm Activation Device (Smoke, Heat or Pull)	_____ Each

NOTE: "Installed" means undercut and fill are measured compacted and in place complete assembly, not by truckload or prior to compaction.

TIME

The Bidder further proposes and agrees hereby to commence work on a date specified in the Architect's Notice to Proceed, and to complete all work according to the schedule of dates set under Article 8 "Time" of the Supplementary Conditions, WHICH ARE DATES CERTAIN, with no allowance for delays except as may be caused by the Owner. Applicable liquidated damages shall be as stated in the Supplementary General Conditions.

HUB PARTICIPATION REQUIREMENTS;

Provide with the bid - Under GS 143-128.2(c) the undersigned bidder shall identify **on its bid** (Identification of HUB Participation Form) the HUB businesses that it will use on the project with the total dollar value of the bids that will be performed by the HUB businesses. **Also** list the good faith efforts (Affidavit **A**) made to solicit HUB participation in the bid effort.

NOTE: A contractor that performs all of the work with its own workforce may submit an Affidavit (**B**) to that effect in lieu of Affidavit (**A**) required above. The HUB Participation Form must still be submitted even if there is zero participation.

After the bid opening - The Owner will consider all bids and alternates and determine the lowest responsible, responsive bidder. Upon notification of being the apparent low bidder, the bidder shall then file within 72 hours of the notification of being the apparent lowest bidder, the following:

An Affidavit (**C**) that includes a description of the portion of work to be executed by HUB businesses, expressed as a percentage of the total contract price, which is equal to or more than the 10% goal established. This affidavit shall give rise to the presumption that the bidder has made the required good faith effort and Affidavit **D** is not necessary;

OR

If less than the 10% goal, Affidavit (**D**) of its good faith effort to meet the goal shall be provided. The document must include evidence of all good faith efforts that were implemented, including any advertisements, solicitations and other specific actions demonstrating recruitment and selection of HUB businesses for participation in the contract.

Note:

Bidders must always submit **with their bid** the Identification of HUB Participation Form listing all HUB contractors, vendors and suppliers that will be used. If there is no HUB participation, then enter none or zero on the form. Affidavit A or Affidavit B, as applicable, also must be submitted with the bid. Failure to file a required affidavit or documentation with the bid or after being notified apparent low bidder is grounds for rejection of the bid.

BYRD ANTI-LOBBYING AMENDMENT CERTIFICATION

In submitting a bid, the undersigned bidder certifies that:

In accordance with federal regulations, it will not and has not used federal appropriated funds to pay any person or organization for influencing or attempting to influence an officer or employee of any agency, a member of Congress, an officer or employee of Congress, or an employee of a member of Congress in connection with obtaining any federal contract, grant or any other award covered by this amendment in connection with this bid, and that it will disclose any lobbying with non-federal funds that takes place in connection with obtaining any federal award in connection with this bid.

Proposal Signature Page

The undersigned further agrees that in the case of failure on his part to execute the said contract and the bonds within ten (10) consecutive calendar days after being given written notice of the award of contract by the Designer, as agent for the Owner, the certified check, cash or bid bond accompanying this bid shall be paid into the funds of the Owner's account set aside for the project, as liquidated damages for such failure; otherwise the certified check, cash or bid bond accompanying this proposal shall be returned to the undersigned.

Respectfully submitted this day of _____

(Name of firm or corporation making bid)

WITNESS:

By: _____
Signature

(Proprietorship or Partnership)

Name: _____
Print or type

Title _____
(Owner / Partner / President / Vice President)

Address _____

ATTEST:

By: _____

License No. _____

Title: _____
(Corp. Sec. or Asst. Sec. only)

Federal I.D. No. _____

(CORPORATE SEAL)

Addendum received and used in computing bid:

Addendum No. 1 _____ Addendum No. 3 _____ Addendum No. 5 _____ Addendum No. 6 _____

Addendum No. 2 _____ Addendum No. 4 _____ Addendum No. 6 _____ Addendum No. 7 _____

GUIDELINES FOR RECRUITMENT AND SELECTION OF MINORITY BUSINESSES FOR PARTICIPATION IN CONSTRUCTION CONTRACTS

In accordance with G.S. 143-128.2 (effective January 1, 2002) these guidelines establish goals for minority participation in single-prime bidding, separate-prime bidding, construction manager at risk, and alternative contracting methods. The legislation provides that the Public Owner shall have a verifiable ten percent (10%) goal for participation by minority businesses in the total value of work for each project for which a contract or contracts are awarded. These requirements are published to accomplish that end.

SECTION A: INTENT

It is the intent of these guidelines that the Owner, as awarding authority for construction projects, and the contractors and subcontractors performing the construction contracts awarded shall cooperate and in good faith do all things legal, proper and reasonable to achieve the statutory goal of ten percent (10%) for participation by minority businesses in each construction project as mandated by GS 143-128.2. Nothing in these guidelines shall be construed to require contractors or awarding authorities to award contracts or subcontracts to or to make purchases of materials or equipment from minority-business contractors or minority-business subcontractors who do not submit the lowest responsible, responsive bid or bids.

SECTION B: DEFINITIONS

1. Minority - a person who is a citizen or lawful permanent resident of the United States and who is:
 - a. Black, that is, a person having origins in any of the black racial groups in Africa;
 - b. Hispanic, that is, a person of Spanish or Portuguese culture with origins in Mexico, South or Central America, or the Caribbean Islands, regardless of race;
 - c. Asian American, that is, a person having origins in any of the original peoples of the Far East, Southeast Asia and Asia, the Indian subcontinent, the Pacific Islands;
 - d. American Indian, that is, a person having origins in any of the original peoples of North America; or
 - e. Female
2. Minority Business - means a business:
 - a. In which at least fifty-one percent (51%) is owned by one or more minority persons, or in the case of a corporation, in which at least fifty-one percent (51%) of the stock is owned by one or more minority persons or socially and economically disadvantaged individuals; and
 - b. Of which the management and daily business operations are controlled by one or more of the minority persons or socially and economically disadvantaged individuals who own it.
3. Socially and economically disadvantaged individual - means the same as defined in 15 U.S.C. 637. "Socially disadvantaged individuals are those who have been subjected to racial or ethnic prejudice or cultural bias because of their identity as a member of a group without regard to their individual qualities". "Economically disadvantaged individuals are those socially disadvantaged individuals whose ability to compete in the free enterprise system has been impaired due to diminished capital and credit opportunities as compared to others in the same business area who are not socially disadvantaged".
4. Public Entity - means the Owner and all public subdivisions and local governmental units.
5. Owner - The public institution named in the contract.

6. Designer – Any person, firm, partnership, or corporation, which has contracted with the Owner to perform architectural or engineering work.
7. Bidder - Any person, firm, partnership, corporation, association, or joint venture seeking to be awarded a public contract or subcontract.
8. Contract - A mutually binding legal relationship or any modification thereof, obligating the seller to furnish equipment, materials or services, including construction, and obligating the buyer to pay for them.
9. Contractor - Any person, firm, partnership, corporation, association, or joint venture which has contracted with the State of North Carolina to perform construction work or repair.
10. Subcontractor - A firm under contract with the prime contractor or construction manager at risk for supplying materials or labor and materials and/or installation. The subcontractor may or may not provide materials in his subcontract.

SECTION C: RESPONSIBILITIES

1. Office for Historically Underutilized Businesses, Department of Administration (hereinafter referred to as HUB Office).

The HUB Office has established a program, which allows interested persons or businesses qualifying as a minority business under G.S. 143-128.2, to obtain certification in the State of North Carolina procurement system. The information provided by the minority businesses will be used by the HUB Office to:

- a. Identify those areas of work for which there are minority businesses, as requested.
- b. Make available to interested parties a list of prospective minority business contractors and subcontractors.
- c. Assist in the determination of technical assistance needed by minority business contractors.

In addition to being responsible for the certification/verification of minority businesses that want to participate in the State construction program, the HUB Office will:

- (1) Maintain a current list of minority businesses. The list shall include the areas of work in which each minority business is interested.
- (2) Inform minority businesses on how to identify and obtain contracting and subcontracting opportunities through the State and other public entities.
- (3) Inform minority businesses of the contracting and subcontracting process for public construction building projects.
- (4) Work with the North Carolina trade and professional organizations to improve the ability of minority businesses to compete in the State construction projects.
- (5) The HUB Office also oversees the minority business program by:
 - a. Monitoring compliance with the program requirements.
 - b. Assisting in the implementation of training and technical assistance programs.
 - c. Identifying and implementing outreach efforts to increase the utilization of minority businesses.
 - d. Reporting the results of minority business utilization to the Secretary of the Department of Administration, the Governor, and the General Assembly.

2. The Owner
The Owner will be responsible for the following:

- a. Reviewing the apparent low bidders' statutory compliance with the requirements listed in the proposal prior to award of contracts. The Owner reserves the right to reject any or all bids and to waive informalities.
 - b. Monitoring of contractors' compliance with minority business requirements in the contract documents during construction.
 - c. Providing statistical data and required reports to the HUB Office.
 - d. Resolving any protest and disputes arising after implementation of the plan.
3. Constituent Institutions of The State of North Carolina
Before awarding a contract, a constituent institution shall do the following:
- a. Implement the constituent institution HUB plan.
 - b. Attend the scheduled prebid conference.
 - c. At least 10 days prior to the scheduled day of bid opening, notify minority businesses that have requested notices from the public entity for public construction or repair work and minority businesses that otherwise indicated to the Office for Historically Underutilized Businesses an interest in the type of work being bid or the potential contracting opportunities listed in the proposal. The notification shall include the following:
 1. A description of the work for which the bid is being solicited.
 2. The date, time, and location where bids are to be submitted.
 3. The name of the individual within the owner's organization who will be available to answer questions about the project.
 4. Where bid documents may be reviewed.
 5. Any special requirements that may exist.
 - d. Utilize other media, as appropriate, likely to inform potential minority businesses of the bid being sought.
 - e. Maintain documentation of any contacts, correspondence, or conversation with minority business firms made in an attempt to meet the goals.
 - f. Review, jointly with the designer, all requirements of G.S. 143-128.2(c) and G.S. 143-128.2(f) – (i.e. bidders' proposals for identification of the minority businesses that will be utilized with corresponding total dollar value of the bid and affidavit listing good faith efforts, or affidavit of self-performance of work, if the contractor will perform work under contract by its own workforce) - prior to recommendation of award.
 - g. Evaluate documentation to determine good faith effort has been achieved for minority business utilization prior to recommendation of award.
 - h. Review prime contractors' pay applications for compliance with minority business utilization commitments prior to payment.
 - i. Document evidence of implementation of Owner's responsibilities.
4. Designer
Under the single-prime bidding, separate prime bidding, construction manager at risk, or alternative contracting method, the designer will:
- a. Attend the scheduled prebid conference to explain minority business requirements to the prospective bidders.
 - b. Assist the owner to identify and notify prospective minority business prime and subcontractors of potential contracting opportunities.
 - c. Maintain documentation of any contacts, correspondence, or conversation with minority business firms made in an attempt to meet the goals.
 - d. Review jointly with the owner, all requirements of G.S. 143-128.2(c) and G.S.143-128.2(f) – (i.e. bidders' proposals for identification of the minority businesses that will be utilized with corresponding total dollar value of the bid and affidavit listing Good Faith Efforts, or affidavit of self-performance of work, if the contractor will perform work under contract by its own workforce) - prior to recommendation of award.

- e. During construction phase of the project, review “MBE Documentation for Contract Payment” – (Appendix E) for compliance with minority business utilization commitments. Submit Appendix E form with monthly pay applications to the owner and forward copies to the Owner.
- f. Make documentation showing evidence of implementation of Designer’s responsibilities available for review by the Owner and HUB Office, upon request.

5. Prime Contractor(s), CM at Risk, and Its First-Tier Subcontractors

Under the single-prime bidding, the separate-prime bidding, construction manager at risk and alternative contracting methods, contractor(s) will:

- a. Attend the scheduled prebid conference.
- b. Identify or determine those work areas of a subcontract where minority businesses may have an interest in performing subcontract work.
- c. At least ten (10) days prior to the scheduled day of bid opening, notify minority businesses of potential subcontracting opportunities listed in the proposal. The notification will include the following:
 - (1) A description of the work for which the subbid is being solicited.
 - (2) The date, time and location where subbids are to be submitted.
 - (3) The name of the individual within the company who will be available to answer questions about the project.
 - (4) Where bid documents may be reviewed.
 - (5) Any special requirements that may exist, such as insurance, licenses, bonds and financial arrangements.

If there are more than three (3) minority businesses in the general locality of the project who offer similar contracting or subcontracting services in the specific trade, the contractor(s) shall notify three (3), but may contact more, if the contractor(s) so desires.

- d. During the bidding process, comply with the contractor(s) requirements listed in the proposal for minority participation.
- e. Identify on the bid, the minority businesses that will be utilized on the project with corresponding total dollar value of the bid and affidavit listing good faith efforts as required by G.S. 143-128.2(c) and G.S. 143-128.2(f).
- f. Make documentation showing evidence of implementation of PM, CM-at-Risk and First-Tier Subcontractor responsibilities available for review by the constituent institution and HUB Office, upon request.
- g. Upon being named the apparent low bidder, the Bidder shall provide one of the following: (1) an affidavit (Affidavit C) that includes a description of the portion of work to be executed by minority businesses, expressed as a percentage of the total contract price, which is equal to or more than the applicable goal; (2) if the percentage is not equal to the applicable goal, then documentation of all good faith efforts taken to meet the goal. Failure to comply with these requirements is grounds for rejection of the bid and award to the next lowest responsible and responsive bidder.
- h. The contractor(s) shall identify the name(s) of minority business subcontractor(s) and corresponding dollar amount of work on the schedule of values. The schedule of values shall be provided as required in Article 31 of the General Conditions of the Contract to facilitate payments to the subcontractors.
- i. The contractor(s) shall submit with each monthly pay request(s) and final payment(s), “MBE Documentation for Contract Payment” – (Appendix E), for designer’s review.
- j. During the construction of a project, at any time, if it becomes necessary to replace a minority business subcontractor, immediately advise the Owner, and the Director of the HUB Office in writing, of the circumstances involved. The prime contractor shall make a good faith effort to replace a minority business subcontractor with another minority business subcontractor.
- k. If during the construction of a project additional subcontracting opportunities become available, make a good faith effort to solicit subbids from minority businesses.
- l. It is the intent of these requirements apply to all contractors performing as prime contractor and first tier subcontractor under construction manager at risk on state projects.

6. Minority Business Responsibilities

While minority businesses are not required to become certified in order to participate in the State construction projects, it is recommended that they become certified and should take advantage of the appropriate technical assistance that is made available. In addition, minority businesses who are contacted by owners or bidders must respond promptly whether or not they wish to submit a bid.

SECTION D: DISPUTE PROCEDURES

It is the policy of this state that disputes that involves a person's rights, duties or privileges, should be settled through informal procedures. To that end, minority business disputes arising under these guidelines should be resolved as governed under G.S. 143-128(g).

SECTION E: These guidelines shall apply upon promulgation on University construction projects.

Copies of these guidelines may be obtained from:

<http://www.NorthCarolina.edu/finance/projects/projects.cfm#attachments>

SECTION F: In addition to these guidelines, there will be issued with each construction bid package provisions for contractual compliance providing MBE participation in State building projects. An explanation of the process follows, titled “MINORITY BUSINESS CONTRACT PROVISIONS (CONSTRUCTION)” along with relevant forms for its implementation (“Identification of Minority Business Participation” form, Affidavits A, B, C, D and Appendix E).

MINORITY BUSINESS CONTRACT PROVISIONS (CONSTRUCTION)

APPLICATION:

The **Guidelines for Recruitment and Selection of Minority Businesses for Participation in State Construction Contracts** are hereby made a part of these contract documents. These guidelines shall apply to all contractors regardless of ownership. Copies of these guidelines may be obtained from: <http://www.NorthCarolina.edu/finance/projects/projects.cfm#attachments>

MINORITY BUSINESS SUBCONTRACT GOALS:

The goals for participation by minority firms as subcontractors on this project have been set at 10%.

The bidder must identify on its bid, the minority businesses that will be utilized on the project with corresponding total dollar value of the bid and affidavit (Affidavit A) listing good faith efforts **or** affidavit (Affidavit B) of self-performance of work, if the bidder will perform work under contract by its own workforce, as required by G.S. 143-128.2(c) and G.S. 143-128.2(f).

The lowest responsible, responsive bidder must provide Affidavit C, that includes a description of the portion of work to be executed by minority businesses, expressed as a percentage of the total contract price, which is equal to or more than the applicable goal.

OR

Provide Affidavit C, that includes a description of the portion of work to be executed by minority businesses, expressed as a percentage of the total contract price, **with documentation of Good Faith Effort, if the percentage is not equal to the applicable goal.**

OR

Provide Affidavit B, which includes sufficient information for the State to determine that the bidder does not customarily subcontract work on this type project.

The above information must be provided as required. Failure to submit these documents is grounds for rejection of the bid.

MINIMUM COMPLIANCE REQUIREMENTS:

All written statements, affidavits or intentions made by the Bidder shall become a part of the agreement between the Contractor and the Owner for performance of this contract. Failure to comply with any of these statements, affidavits, or intentions, or with the minority business Guidelines shall constitute a breach of the contract. A finding by the Owner that any information submitted either prior to award of the contract or during the performance of the contract is inaccurate, false or incomplete, shall also constitute a breach of the contract. Any such breach may result in termination of the contract in accordance with the termination provisions contained in the contract. It shall be solely at the option of the Owner whether to terminate the contract for breach.

In determining whether a contractor has made Good Faith Efforts, the Owner will evaluate all efforts made by the Contractor and will determine compliance in regard to quantity, intensity, and results of these efforts. Good Faith Efforts include:

- (1) Contacting minority businesses that reasonably could have been expected to submit a quote and that were known to the contractor or available on State or local government maintained lists at least 10 days before the bid or proposal date and notifying them of the nature and scope of the work to be performed.
- (2) Making the construction plans, specifications and requirements available for review by prospective minority businesses, or providing these documents to them at least 10 days before the bid or proposals are due.
- (3) Breaking down or combining elements of work into economically feasible units to facilitate minority participation.
- (4) Working with minority trade, community, or contractor organizations identified by the Office for Historically Underutilized Businesses and included in the bid documents that provide assistance in recruitment of minority businesses.
- (5) Attending any prebid meetings scheduled by the public owner.
- (6) Providing assistance in getting required bonding or insurance or providing alternatives to bonding or insurance for subcontractors.
- (7) Negotiating in good faith with interested minority businesses and not rejecting them as unqualified without sound reasons based on their capabilities. Any rejection of a minority business based on lack of qualification should have the reasons documented in writing.
- (8) Providing assistance to an otherwise qualified minority business in need of equipment, loan capital, lines of credit, or joint pay agreements to secure loans, supplies, or letters of credit, including waiving credit that is ordinarily required. Assisting minority businesses in obtaining the same unit pricing with the bidder's suppliers in order to help minority businesses in establishing credit.
- (9) Negotiating joint venture and partnership arrangements with minority businesses in order to increase opportunities for minority business participation on a public construction or repair project when possible.
- (10) Providing quick pay agreements and policies to enable minority contractors and suppliers to meet cash-flow demands.

AFFIDAVIT A – Listing of the Good Faith Effort

County of _____

Affidavit of _____
(Bidder)

I have made a good faith effort to comply under the following areas checked:

(A minimum of 5 areas must be checked in order to have achieved a "good faith effort")

- 1 - Contacted minority businesses that reasonably could have been expected to submit a quote and that were known to the contractor, or available on State or local government maintained lists, at least 10 days before the bid date and notified them of the nature and scope of the work to be performed.
- 2 - Made the construction plans, specifications and requirements available for review by prospective minority businesses, or providing these documents to them at least 10 days before the bids are due.
- 3 - Broken down or combined elements of work into economically feasible units to facilitate minority participation.
- 4 - Worked with minority trade, community, or contractor organizations identified by the Office of Historically Underutilized Businesses and included in the bid documents that provide assistance in recruitment of minority businesses.
- 5 - Attended prebid meetings scheduled by the public owner.
- 6 - Provided assistance in getting required bonding or insurance or provided alternatives to bonding or insurance for subcontractors.
- 7 - Negotiated in good faith with interested minority businesses and did not reject them as unqualified without sound reasons based on their capabilities. Any rejection of a minority business based on lack of qualification should have the reasons documented in writing.
- 8 - Provided assistance to an otherwise qualified minority business in need of equipment, loan capital, lines of credit, or joint pay agreements to secure loans, supplies, or letters of credit, including waiving credit that is ordinarily required. Assisted minority businesses in obtaining the same unit pricing with the bidder's suppliers, in order to help minority businesses in establishing credit.
- 9 - Negotiated joint venture and partnership arrangements with minority businesses in order to increase opportunities for minority business participation on a public construction or repair project when possible.
- 10 - Provided quick pay agreements and policies to enable minority contractors and suppliers to meet cash-flow demands.

In accordance with GS143-128.2(d) the undersigned will enter into a formal agreement with the firms Listed, in the Identification of Minority Business Participation schedule conditional upon execution of a contract with the Owner. Failure to abide by this statutory provision will constitute a breach of the contract.

The undersigned hereby certifies that he or she has read the terms of the minority business commitment and is authorized to bind the bidder to the commitment herein set forth.

Date: _____ Name of Authorized Officer: _____

Signature: _____

Title: _____

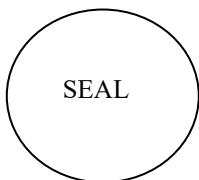

State of North Carolina, County of _____
Subscribed and sworn to before me this _____ day of _____ 20____
Notary Public _____
My commission expires _____

AFFIDAVIT B – Intent to Perform Contract with Own Workforce.

County of _____

Affidavit of _____

(Name of Bidder)

I hereby certify that it is our intent to perform 100% of the work required for the _____ contract.

(Name of Project)

In making this certification, the Bidder states that the Bidder does not customarily subcontract elements of this type project, and normally performs and has the capability to perform and will perform all elements of the work on this project with his/her own current work forces; and

The Bidder agrees to provide any additional information or documentation requested by the owner in support of the above statement.

The undersigned hereby certifies that he or she has read this certification and is authorized to bind the Bidder to the commitments herein contained.

Date: _____ Name of Authorized Officer _____

Signature: _____

Title: _____

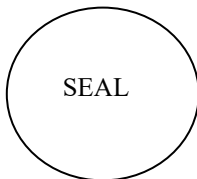

State of North Carolina, County of _____

Subscribed and sworn to before me this _____ day of _____ 20__

Notary Public _____

My commission expires _____

AFFIDAVIT C - Portion of the Work to be Performed by Minority Firms

Project _____

*******(NOTE: THIS FORM IS NOT TO BE SUBMITTED WITH THE BID PROPOSAL)*******

If the portion of the work to be executed by minority businesses as defined in GS143-128.2(g) is equal to or greater than 10% of the bidders total contract price, then the bidder must complete this affidavit. This affidavit shall be provided by the apparent lowest responsible, responsive bidder within 72 hours after notification of being low bidder.

Affidavit of: _____ I do hereby certify that on the
(Bidder)

_____ (Project Name)

Amount of Bid \$ _____

I will expend a minimum of _____% of the total dollar amount of the contract with minority business enterprises. Minority Businesses will be employed as construction subcontractors, vendors, suppliers or providers of professional services. Such work will be subcontracted to the following firms listed below.

Attach additional sheets if required.

Name and Phone Number	*Minority Category	Work description	Dollar Value

*Minority categories: Black, African American (**B**), Hispanic (**H**), Asian American (**A**) American Indian (**I**), Female (**F**) Socially and Economically Disadvantaged (**D**)

Pursuant to GS143-128.2(d), the undersigned will enter into a formal agreement with Minority Firms for work listed in this schedule conditional upon execution of a contract with the Owner. Failure to fulfill this commitment may constitute a breach of the contract.

The undersigned hereby certifies that he or she has read the terms of this commitment and is authorized to bind the bidder to the commitment herein set forth.

Date: _____ Name of Authorized Officer: _____

Signature: _____

Title: _____

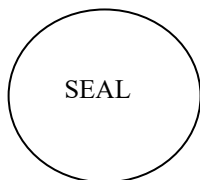

State of North Carolina, County of _____
 Subscribed and sworn to before me this _____ day of _____ 20____
 Notary Public _____
 My commission expires _____

AFFIDAVIT D – Good Faith Efforts

Project _____

If the goal of 10% participation by minority business **is not** achieved, the Bidder shall provide the following documentation to the Owner of his good faith efforts

(Bidder

Affidavit of: _____)

I do certify the attached documentation as true and accurate representation of my good faith efforts.

(Attach additional sheets if required)

Name and Phone Number	*Minority Category	Work description	Dollar Value

*Minority categories: Black, African American (**B**), Hispanic (**H**), Asian American (**A**) American Indian (**I**), Female (**F**) Socially and Economically Disadvantaged (**D**)

Documentation of the Bidder's good faith efforts to meet the goals set forth in these provisions.

Examples of documentation shall include the following evidence:

- A. Copies of solicitations for quotes to at least three (3) minority business firms from the source list provided by the State for each subcontract to be let under this contract (if 3 or more firms are shown on the source list). Each solicitation shall contain a specific description of the work to be subcontracted, location where bid documents can be reviewed, representative of the Prime Bidder to contact, and location, date and time when quotes must be received.
- B. Copies of quotes or responses received from each firm responding to the solicitation.
- C. A telephone log of follow-up calls to each firm sent a solicitation.
- D. For subcontracts where a minority business firm is not considered the lowest responsible sub-bidder, copies of quotes received from all firms submitting quotes for that particular subcontract.
- E. Documentation of any contacts or correspondence to minority business, community, or contractor organizations in an attempt to meet the goal.
- F. Copy of pre-bid roster.
- G. Letter documenting efforts to provide assistance in obtaining required bonding or insurance for minority business.
- H. Letter detailing reasons for rejection of minority business due to lack of qualification.
- I. Letter documenting proposed assistance offered to minority businesses in need of equipment, loan capital, lines of credit, or joint pay agreements to secure loans, supplies, or letter of credit, including waiving credit that is ordinarily required.

Failure to provide the documentation as listed in these provisions may result in rejection of the bid and award to the next lowest responsible and responsive bidder.

Date: _____ Name of Authorized Officer: _____

Signature: _____

Title: _____

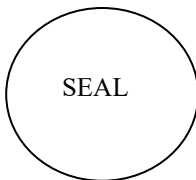

State of North Carolina, County of _____

Subscribed and sworn to before me this _____ day of _____ 20 _____

Notary Public _____

My commission expires _____

APPENDIX E

MBE DOCUMENTATION FOR CONTRACT PAYMENTS

Prime Contractor/Architect: _____

Address & Phone: _____

Project Name: _____

Pay Application #: _____ Period: _____

The following is a list of payments to be made to minority business contractors on this project for the above-mentioned period.

Firm Name	*Minority Category	Payment Amount (List invoice number and amount)	Owner Use Only

*Minority categories: Black, African American (**B**), Hispanic (**H**), Asian American (**A**) American Indian (**I**), Female (**F**) Socially and Economically Disadvantaged (**D**)

Date: _____ Approved/Certified By: _____

Name

Title

Signature

****THIS DOCUMENT MUST BE SUBMITTED WITH EACH PAY REQUEST & FINAL PAYMENT****

OWNER-CONTRACTOR AGREEMENT

PROJECT NUMBER: 22344

SCHOOL NAME: New Beaufort PK-3 School

THIS AGREEMENT, in four (4) copies, made this () day of _____, Two Thousand and Twenty Four by and between Beaufort County Schools Board of Education (herein referred to as the "Owner"), whose mailing address is 321 Smaw Road, Washington, NC 27889 and _____ (herein referred to as the "Contractor"), whose mailing address is _____. Correspondence, submittals, and notices relating to or required under this Contract shall be sent in writing to the above addresses; unless either party is notified in writing by the other, of a change in address.

WITNESSETH:

WHEREAS, it is the intent of the Owner to obtain the services of the Contractor in connection with the new construction of New Beaufort PK-3 School (hereinafter referred to as the "Project" or the "Work"); and

WHEREAS, the Contractor desires to perform such construction in accordance with the terms and conditions of this Agreement,

NOW, THEREFORE, in consideration of the promises made herein and other good and valuable consideration, the following terms and conditions are hereby mutually agreed to, by and between the Owner and Contractor:

Article 1

DEFINITIONS

- 1.1 All terms in this Agreement which are defined in the Information for Bidders and the General Conditions shall have the meanings designated therein.
- 1.2 The Contract Documents are as defined in the General Conditions. Such documents form the Contract, and all are as fully a part thereof as if attached to this Agreement or repeated herein. The Contract Documents consist of the Owner-Contractor Agreement, the General and Supplemental Conditions of the Contract, the Drawings, the Specifications, all Addenda issued prior to bidding, and all Modifications and Change Orders issued after execution of the Contract.

Article 2

STATEMENT OF THE WORK

2.1 The Project is the Work identified in the plans and specifications prepared by Hite Associates, PC dated May 2024 for Beaufort County Board of Education, including the following addenda:

[REDACTED]

A listing of the plans and specifications included in the Contract Documents is attached as Exhibit A.

2.2 The Parties agree that the Project shall include the following alternates:

[REDACTED]

2.3 The Parties agree to the following modifications to the Project's plans and specifications, including the noted value engineering items:

List item(s) and proposed deduct/add(s). If none, delete this language list "None"

2.4 The Parties agree that the following allowances are included in the Contract Sum in Section 5.1 below:

List item(s) and proposed allowance(s). If none, delete this language list "None"

2.5 The Contractor shall provide and pay for all materials, tools, equipment, labor and professional and non-professional services, and shall perform all other acts and supply all other things necessary, to fully and properly perform and complete the Work, as required by the Contract Documents.

2.6 The Contractor shall further provide and pay for all related facilities described in any of the Contract Documents, including all work expressly specified therein and such additional work as may be reasonably inferred therefrom, saving and excepting only such items of work as are specifically stated in the Contract Documents not to be the obligation of the Contractor. The totality of the obligations imposed upon the contractor by this Article and by all other provisions of the Contract Documents, as well as the structures to be built and the labor to be performed, is herein referred to as the "Work".

Article 3

DESIGN CONSULTANT

3.1 The Design Consultant (as defined in the General Conditions) shall be Hite Associates, PC whose address is 2600 Meridian Drive, Greenville, NC 27834, however, that the Owner may, without liability to the Contractor, unilaterally amend this Article from time to time by designating a different person or organization to act as its Design Consultant and so advising the Contractor in writing, at which time the person or organization so designated shall be the Design Consultant for purposes of this Contract.

Article 4

TIME OF COMMENCEMENT AND COMPLETION

- 4.1 The Contractor shall commence the Work promptly upon the date established in the Notice to Proceed. If there is no Notice to Proceed, the date of commencement of the Work shall be the date of this Agreement or such other date as may be established herein.
- 4.2 Time is of the essence. The Contractor shall achieve Final Completion, as defined in the General Conditions on or before the date established for Final Completion in the Supplemental Conditions.
- 4.3 The Supplemental Conditions contains certain specific dates that shall be adhered to and are the last acceptable dates unless modified in writing by mutual agreement between the Contractor and the Owner. All dates indicate midnight unless otherwise stipulated. The only exceptions to this schedule are defined in the General Conditions under 8.3 DELAYS AND EXTENSIONS OF TIME.
- 4.4 Should the Contractor fail to complete the Work on or before the dates stipulated for Substantial Completion and/or Final Completion, or such later date as may result from an extension of time granted by the Owner, he shall pay the Owner, as liquidated damages the sums set forth in the General and Supplemental Conditions.

Article 5

CONTRACT SUM

- 5.1 Provided that the Contractor shall strictly and completely perform all of its obligations under the Contract Documents, and subject only to additions and deductions by Modification or as otherwise provided in the Contract Documents, the Owner shall pay to the Contractor, in current funds and at the time and in the installments hereinafter specified, the sum of [REDACTED] Dollars (\$ [REDACTED]) herein referred to as the "Contract Sum". This amount includes the base bid and the Alternates in Section 2.2
- 5.2 The Contract Sum includes the value engineering items and other contract modifications noted in Section 2.3 above that total \$_____.
- 5.3 Unit Prices are established as follows for the Project:

Unit Price No. 1		\$
Unit Price No. 2		\$
Unit Price No. 3		\$
Unit Price No. 4		\$

Unit Price No. 5		\$
Unit Price No. 6		\$
Unit Price No. 7		\$
Unit Price No. 8		\$

Article 6

PROGRESS PAYMENTS

6.1 The Contractor hereby agrees that on or about the First day of the month for every month during the performance of the Work he will deliver to the Owner's Project Manager an Application for Payment in accordance with the provisions of Article 9 of the General Conditions. This date may be changed upon mutual agreement, stated in writing, between the Owner and Contractor. Payment under this Contract shall be made as provided in the General Conditions. Payments due and unpaid under the Contract Documents shall not bear interest.

Article 7

OTHER REQUIREMENTS

7.1 The Contractor shall submit the Performance Bond, Labor and Material Payment Bond and Certification of Insurance as required by the Contract Documents.

7.2 The Owner shall furnish to the Contractor one (1) set of drawings and one (1) set of specifications, at no extra cost, for use in the Construction of the Work. Additional sets of drawings or specifications may be obtained by the Contractor by paying the Owner for the costs of reproduction, handling and mailing.

7.3 The Contractor shall make a good faith effort to utilize Historically Underutilized Businesses (HUB's) per N.C. Gen. Stat. 143-128.2, and as described in the construction documents.

7.4 The General Conditions, Supplemental Conditions and the plans and specifications, including any addenda, are incorporated herein by reference.

IN WITNESS WHEREOF, Beaufort County Board of Education (hereinbefore called the "Owner") has caused these presents to be signed and its corporate seal to be hereunto affixed, attested by its Chairperson and Secretary, and _____ (hereinbefore called "Contractor") has caused these presents to be signed by its President and its Corporate seal to be hereunto affixed, as hereinafter attested, all as of the day and year first above written.

BEAUFORT COUNTY BOARD OF EDUCATION

Board Chairperson

ATTEST:

Superintendent

[Corporate Seal]

By: _____, President or Vice-President
(Print Name)

ATTEST:

Corporate Secretary

[Corporate Seal]

This instrument has been preaudited in the manner required by the School Budget and Fiscal Control Act.

Finance Officer

Date

PERFORMANCE BOND

IT IS HEREBY AGREED that

(Insert full name and address of Contractor)

as Principal, hereinafter called Contractor, and,

(Insert full name and address of Surety)

as Surety, hereinafter called Surety, are held and firmly bound unto the

as Obligee, hereinafter called Owner, in the amount of _____ Dollars (\$ _____), for the payment whereof Contractor and Surety bind themselves, their heirs, executors, administrators, successors and assigns, jointly and severally, firmly by these obligations.

WHEREAS, Contractor has by written agreement dated _____, 20____, entered into a contract with Owner for the construction of _____ (Insert the name of the Project)

in accordance with Drawings and Specifications prepared by _____ (Insert full name and address of Architect/Engineer)

which contract is by reference made a part hereof, and is hereinafter referred to as the Contract.

NOW, THEREFORE, THE CONDITION OF THIS OBLIGATION is such that, if Contractor shall promptly and faithfully perform said Contract, then this obligation shall be null and void; otherwise it shall remain in full force and effect. The Surety hereby waives notice of any alteration or extension of time made by the Owner.

Whenever Contractor shall be, and declared by Owner to be in default, under the Contract, the Owner having performed Owner's obligations thereunder, the Surety may promptly remedy the default, or shall promptly:

- 1) Complete the Contract in accordance with its terms and conditions, or
- 2) Obtain a bid or bids for completing the Contract in accordance with its terms and conditions, and upon determination by Surety of the lowest responsible bidder, or, if the Owner elects, upon determination by the Owner and the Surety jointly of the lowest responsible bidder, arrange for a contract between such bidder and Owner, and make available as Work progresses (even though there should be a default or a succession of

defaults under the contract or contracts of completion arranged under this paragraph) sufficient funds to pay the cost of completion less the balance of the contract price; but not exceeding, including other costs and damages for which the Surety may be liable hereunder, the amount set forth in the first paragraph hereof. The term "balance of the contract price," as used in this paragraph, shall mean the total amount payable by Owner to Contractor under the Contract and any amendments thereto, less the amount properly paid by Owner to Contractor.

Any suit under this bond must be instituted before the expiration of any applicable statute of limitations under the Contract.

No right of action shall accrue on this bond to or for the use of any person or corporation other than the Owner named herein or the heirs, executors, administrators or successors of the Owner.

Signed and sealed this _____ day of _____ 20_____.

PRINCIPAL

[Affix corporate seal]

(Name) _____
(Title) _____

(Witness)

SURETY

[Affix corporate seal]

(Name) _____
(Title) _____

(Witness)

LABOR AND MATERIAL PAYMENT BOND

THIS BOND IS ISSUED SIMULTANEOUSLY WITH PERFORMANCE BOND IN FAVOR OF THE OWNER CONDITIONED ON THE FULL AND FAITHFUL PERFORMANCE OF THE CONTRACT

IT IS HEREBY AGREED that (Insert full name and address of Contractor)

as Principal, hereinafter called "Principal," and, (Insert full name and address of Surety)

as Surety, hereinafter called "Surety," are held and firmly bound unto the

as Oblige, hereinafter called Owner, for the use and benefit of claimants as hereinbelow defined, in the amount of _____ for the payment whereof Principal and Surety bind themselves, their heirs, executors, administrators, successors and assigns, jointly and severally, firmly by these obligations.

WHEREAS, Principal has by written agreement dated _____, 20____, entered into a contract with Owner for the construction of _____ (Insert the name of the Project)

in accordance with Drawings and Specifications prepared by _____ (Insert full name and address of Architect/Engineer)

which contract is by reference made a part hereof, and is hereinafter referred to as the "Contract."

NOW, THEREFORE, THE CONDITION OF THIS OBLIGATION is such that, if Principal shall promptly make payment to all claimants as hereinafter defined, for all labor and material used or reasonably required for use in the performance of the Contract, then this obligation shall be void; otherwise it shall remain in full force and effect, subject, however, to the following conditions:

1. A claimant is defined as one having a direct contract with the principal or with a Subcontractor of the Principal for labor, material, or both, used or reasonably required for use in the performance of the Contract, labor and material being construed to include that part of water, gas, power, light, heat, oil, gasoline, telephone service or rental of equipment directly applicable to the Contract.
2. The above named Principal and Surety hereby jointly and severally agree with the Owner that every claimant as herein defined, who has not been paid in full before the expiration of a period of ninety (90) days after the date on which the last of such claimant's work or labor was done or performed, or materials were furnished by such claimant, may sue on this bond for the use of such claimant, prosecute the suit to final judgment for such sum or sums as may be justly due claimant, and have execution thereon. The Owner shall not be liable for the payment of any costs or expenses of any such suit.
3. No suit or action shall be commenced hereunder by any claimant:
 - a) Unless claimant, other than one having a direct contract with the Principal, shall have given written notice to any two of the following: the Principal, the Owner, or the Surety above named, within ninety (90) days, after such claimant did or performed the last of the work or labor, or furnished the last of the materials for which said claim is made, stating with substantial accuracy the amount claimed and the name of the party to whom the materials were furnished, or for whom the work or labor was done or performed. Such notice shall be served by mailing the same by registered mail or certified mail; postage prepaid, in an envelope addressed to the Principal, Owner or Surety, at

any place where an office is regularly maintained for the transaction of business, or served in any manner in which legal process may be served in the state in which the aforesaid project is located, save that such service need not be made by a public officer.

b) After the expiration of one (1) year following the date on which Principal ceased Work on said Contract, it being understood, however, that if any limitation embodied in this bond is prohibited by any law controlling the construction hereof such limitation shall be deemed to be amended so as to be equal to the minimum period of limitation permitted by such law.

c) Other than in a state court of competent jurisdiction in and for the county or other political subdivision of the state in which the Project, or any part thereof, is situated, or in the United States District Court for the district in which the Project, or any part thereof, is situated, and not elsewhere.

4. The amount of this bond shall be reduced by and to the extent of any payment or payments made in good faith hereunder, inclusive of the payment by Surety of mechanics' liens which may be filed of record against said improvement, whether or not claim for the amount of such lien be presented under and against this bond.

Signed and sealed this ____ day of _____ 20 ____.

PRINCIPAL

[Affix corporate seal]

(Name) _____
(Title) _____

(Witness)

SURETY

[Affix corporate seal]

(Name) _____
(Title) _____

(Witness)

LEA/System #: Beaufort County Schools, #070

School Name and No: Eastern Elementary

Building(s): All

School Address: 947 Hudnell Street Washington, NC 27889

Reinspection Date: 04May2021

AHERA REINSPECTION REPORT

All previously identified or newly discovered friable and nonfriable asbestos containing building material (ACBM) has been reinspected/assessed and findings specified below:

1. BUILDING AND FUNCTIONAL SPACE	2. HGA ID	N	3. MATERIAL DESCRIPTION (Friable/Nonfriable)	4. ASSESSMENT			5. RESPONSE ACTION	
				a. No Change	b. Condition Code	c. Comments	Description	Begin/End Dates
Building A (Main)	EES-A-07		TSI-NF Randomly Distributed Pipe Fittings.		5	Some pipe joints had gaps that could have future fiber release.	Monitor Under O&M See Comments Sheet	04May21- Ongoing
Building A (Main)	EES-A-08		TSI-NF Randomly Distributed Pipe Insulation		5	Some pipe joints had gaps that could have future fiber release. Approx. 1,986SF of Piping	Monitor Under O&M See Comments Sheet	04May21- Ongoing
Pod 2	EES-B-02		9" Floor Tile White/Grey. Misc. Non Friable		4	Room 21 has 9 damaged tiles. Room 24 has 2 damaged tiles	See Comments Sheet	04May21- Ongoing
Pod 2	M-1		Mastic Associated with 9" FT. Misc. NF	X	5		See Comments Sheet	
All	CB-1		Black Covebase mastic. Misc. NF	X			Approx. 8,090SF	
Pods 1,3,4,5,6,7 8 and 9		X	9" Floor Tile and Associated Mastic. Misc. Non Friable		5	Material not documented on previous reinspection. Homogeneous with 9" Flooring in Pod 2	Approx. 27,200 SF	04May21- Ongoing

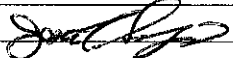
INSPECTOR: Typed Name: Jason T. Simpson Signature: 
 NC Accreditation Number: 12882 Date: 02Jul21

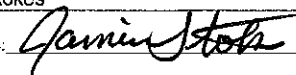
LEA DESIGNEE: Typed Name: Jaime Stokes Signature: 
 Date: 7-26-21

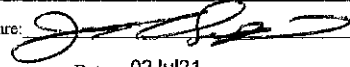
MANAGEMENT PLANNER: Typed Name: Jason T. Simpson Signature: 
 NC Accreditation Number: 20998 Date: 02Jul21

LEA/System #: Beaufort County Schools

School Name and No.: Eastern Elementary

Building: Main, Pods 1,2,3,4,5,6,7,8,9

AHERA REINSPECTION REPORT COMMENTS

HGA ID: EES-A-07 and EES-A-08 **MATERIAL DESCRIPTION:** TSI Insulation and Fitting Material

Upon observing this material it was noted that there were gaps where pipe joints were located facilitating material to become airborne if struck or moved. After relaying this information to the LEA Designee, a contractor was brought in to repair the gaps in the joints to encapsulate the material in those areas. It should be noted that this boiler system in which this material is associated with is abandoned and not operational. Material should still be removed at a time when feasibly possible. This material will be monitored under the O&M plan.

HGA ID: EES=B-02 **MATERIAL DESCRIPTION:** 9" Floor Tile and Mastic

This material is located in Pod 2 as noted on the previous inspection. It is also present in the other 8 pods on site. This material is in relatively good condition. Damaged tiles were quantified during the 2021 site visit and the total was shared with the LEA Designee. Immediately after the visit, a contractor was brought in and removed the damaged tiles and mastic associated with them so the maintenance personnel could install replacement tiles. The total of tiles removed was approx. 340SF. This material will remain under surveillance and O&M plan.

AHERA PERIODIC SURVEY FORM

School / Facility: <u>Eastern Elementary School</u>	Form Author: <u>Jamie Stokes</u>
Date: <u>12-15-21</u>	Author Signature: <u>Jamie Stokes</u>

Building / Area	Sample #	Material	Friable (Y/N)	Condition	Any Change (Y/N)	Comments
Building A main	EES-A-07	TST-NF Randomly distributed pipe fittings	N	5 no change	N	
Building A main	EES-A-08	TST-NF Randomly distributed pipe insulation	N	5 No change	N	Some joints have gaps.
Pod 2	EES-B-02	9" floor Tile white/grey misc non friable	N	(4) Good	Y	damaged Tiles Removed.
Pod 2	M-1	MASTIC ASSOCIATED WITH 9" FT MISC NF		5 Good	Y	Removed and new Tiles Applied.
All	CB-1	Black Cue base mastic	N	5	N	
Pods, 1, 3, 4, 5, 6, 7, 8 and 9		9" floor Tiles and Associated Mastic		(5) Good shape	N	Good

AHERA PERIODIC SURVEY FORM

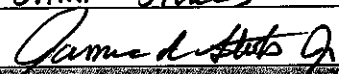
School / Facility:	Eastern Elementary School	Form Author:	Jamie Stokes			
Date:	6.15.22	Author Signature:				
Building / Area	Sample #	Material	Friable (Y/N)	Condition	Any Change (Y/N)	Comments
Building A main	EES-A-07	TST-NF Randomly distributed pipe fittings	N	5 No change	N	
Building A main	EES-A-08	TST-NF Randomly distributed pipe insulation	N	5 No change	N	Some joints have gaps.
Pod 2	EES-B-02	9" floor Tile white/grey misc non friable	N	(4) Good	Y	damaged Tiles Removed.
Pod 2	M-1	MASTIC ASSOCIATED WITH 9" FT MISC NF		5 Good	Y	Removed and new Tiles applied.
All	CB-1	Black Cue base mastic	N	5	N	
Pods, 1, 3, 4, 5, 6, 7, 8 and 9		9" floor Tiles and Associated mastic		(5) Good shape	N	Good

AHERA PERIODIC SURVEY FORM

School / Facility:	Eastern Elementary School	Form Author:	Jamie Hukes
Date:	12-14-22	Author Signature:	<i>Jamie Hukes</i>

Building / Area	Sample #	Material	Friable (Y/N)	Condition	Any Change (Y/N)	Comments
Building A main	EES-A-07	TST-NF Randomly distributed pipe fittings	N	5 no change	N	
Building A main	EES-A-08	TST-NF Randomly distributed pipe insulation	N	5 no change	N	Some joints have GAPS.
Pod 2	EES-B-02	9" floor Tile white/grey misc non friable	N	(4) Good	Y	damaged Tiles Removed.
Pod 2	M-1	MASTIC associated with 9" Ft misc NF		5 Good	Y	Removed and new Tiles applied.
All	CB-1	Black Cue base mastic	N	5	N	
Pods, 1, 3, 4, 5, 6, 7, 8 and 9		9" floor Tiles and associated mastic		(5) Good shape	N	Good

AHERA PERIODIC SURVEY FORM

School / Facility: <u>Eastern Elementary School</u>	Form Author: <u>Jamie Stokes</u>
Date: <u>6-21-23</u>	Author Signature: <u>Jamie Stokes</u>

Building / Area	Sample #	Material	Friable (Y/N)	Condition	Any Change (Y/N)	Comments
Building A main	EES-A-07	TST-NF Randomly distributed pipe fittings	N	5 No change	N	
Building A main	EES-A-08	TSE-NF Randomly distributed pipe insulation	N	5 No change	N	Some joints have gaps.
Pod 2	EES-B-02	9" floor Tile white/grey misc non friable	N	(4) Good	Y	damaged Tiles Removed.
Pod 2	M-1	Mastic associated with 9" ft misc NF		5 Good	Y	Removed and new Tiles applied.
All	CB-1	Black Cue base mastic	N	5	N	
Pods, 1, 3, 4, 5, 6, 7, 8 and 9		9" floor Tiles and associated mastic		(5) Good shape	N	Good

AHERA PERIODIC SURVEY FORM

School / Facility: <u>Eastern Elementary School</u>	Form Author: <u>Jamie Stokes</u>
Date: <u>12-18-23</u>	Author Signature: <u>Jamie Stokes</u>

Building / Area	Sample #	Material	Friable (Y/N)	Condition	Any Change (Y/N)	Comments
Building A main	EES-A-07	TST-NF Randomly distributed pipe fittings	N	5 no change	N	
Building A main	EES-A-08	TST-NF Randomly distributed pipe insulation	N	5 No change	N	Some joints have gaps.
Pod 2	EES-B-02	9" floor Tile white/grey mix non friable	N	(4) Good	Y	damaged Tiles Removed.
Pod 2	M-1	MASTIC ASSOCIATED WITH 9" FT MIX NF		5 Good	Y	Removed and new Tiles applied.
All	CB-1	Black Cue base mastic	N	5	N	
Pods, 1, 3, 4, 5, 6, 7, 8 and 9		9" floor Tiles and Associated mastic		(5) Good shape	N	Good

AHERA PERIODIC SURVEY FORM

School / Facility: <u>Eastern Elementary School</u>	Form Author: <u>Jamie Stokes</u>
Date: _____	Author Signature: <u>Jamie Stokes</u>

Building / Area	Sample #	Material	Friable (Y/N)	Condition	Any Change (Y/N)	Comments
Building A main	EES-A-07	TST-NF Randomly distributed pipe fittings	N	5 no change	N	
Building A main	EES-A-08	TST-NF Randomly distributed pipe insulation	N	5 No change	N	Some joints have GAPS.
Pod 2	EES-A-02	9" floor Tile white/grey misc non friable	N	(4) Good	Y	damaged Tiles Removed.
Pod 2	M-1	MASTIC ASSOCIATED with 9" FT MISC NF		5 Good	Y	Removed and new Tiles applied.
All	CB-1	Black Gue base mastic	N	5	N	
Pods, 1, 3, 4, 5, 6, 7, 8 and 9		9" floor Tiles and Associated mastic		(5) Good shape	N	Good

GO TO NEXT PAGE

GENERAL CONDITIONS

NOTICE OF DISCLAIMER

TAKE NOTICE, that these General Conditions may contain language and Article, Section or Paragraph headings or names which appear similar to or the same as the provisions of the "General Conditions of the Contract for Construction", published by the American Institute of Architects, AIA Document A-201.

TAKE NOTICE, however, that these General Conditions are substantially and materially different in many respects from the AIA Document A-201 and that certain additions, deletions or other modifications have been made to provisions similar to those contained in the AIA Document. This document, further, contains provisions, which do not appear in the AIA document.

The use of any language or Article or Paragraph format similar to or the same as AIA Document A-201 does not constitute an endorsement by the American Institute of Architects of this document.

GENERAL CONDITIONS OF THE CONTRACT FOR CONSTRUCTION

TABLE OF ARTICLES

1. CONTRACT DOCUMENTS	9. PAYMENTS AND COMPLETION
2. DESIGN CONSULTANT	10. PROTECTION OF PERSONS AND PROPERTY
3. OWNER	11. INSURANCE
4. CONTRACTOR	12. CHANGES IN THE WORK
5. SUBCONTRACTORS	13. UNCOVERING AND CORRECTION
6. WORK BY OWNER OR BY SEPARATE CONTRACTORS	14. TERMINATION OF THE CONTRACT
7. MISCELLANEOUS PROVISIONS	15. DISPUTE RESOLUTION
8. TIME	

ARTICLE 1

CONTRACT DOCUMENTS

- 1.1 DEFINITIONS
 - 1.1.1 AS SHOWN, AS INDICATED, AS DETAILED: These words, and words of like implication, refer to information contained in Drawings and Specifications describing the Work, unless explicitly stated otherwise in the Contract Documents.
 - 1.1.2 CLAIM: A Claim as used in the Contract is a demand or assertion by one of the parties seeking, as a matter of right, adjustment or interpretation of contract terms, payment of money, a credit against the payment of money, extension of time or other relief with respect to the terms of the Contract. The term Claim also includes other disputes and matters in question between the parties to a contract involved in the Owner's construction and repair projects arising out of or relating to the Contract or the construction process.

- 1.1.3 **CONTRACT:** The Contract is the sum of all the Contract Documents. The Contract represents the entire and integrated agreement between the Owner and the Contractor and supersedes all prior negotiations, representations, or agreements, either written or oral. The Contract may be amended or modified only by a Modification as defined in Paragraph 1.1.4. The Contract may also be referred to in the Contract Documents as “this Contract”, “this Agreement” or “the Agreement”.
- 1.1.4 **CONTRACT DOCUMENTS:** The Contract Documents consist of the Owner-Contractor Agreement, the Conditions of the Contract (General and Supplemental Conditions), the Plans, Drawings, and Specifications, and all Addenda thereto issued prior to and all Modifications thereto issued after execution of the Contract. A Modification is (1) a written amendment to the Contract signed by both parties; (2) a Change Order or a Construction Change Directive issued pursuant to the provisions of Article 12; (3) a written interpretation issued by the Design Consultant pursuant to Paragraph 2.2.7; or (4) a written order for a minor Change in the Work issued pursuant to Section 12.4. The Contract Documents do not include any other documents including but not limited to soils, geotechnical or other reports, surveys and analysis, which may be printed, bound or assembled with the Contract Documents, or otherwise made available to the Contractor for review or information under this Contract, unless specifically enumerated and directly incorporated by reference in the Contract Documents.
- 1.1.5 **HE/HIS:** The term He or His is not intended to be gender specific.
- 1.1.6 **MANUFACTURER:** An individual, company, or corporation who manufactures, fabricates, or assembles a standard product. A standard product is one that is not made to special design, and if furnished by either direct sale or by contract to the Contractor, Subcontractor or Vendor.
- 1.1.7 **MATERIAL SUPPLIER OR VENDOR:** A person or organization who supplies, but who is not responsible for the installation of, materials, products and equipment.
- 1.1.8 **NOTICE:** The term Notice as used herein shall mean and include written notice. Notice shall be deemed to have been given when delivered to the address of the person, firm or corporation for whom intended, or to his, their or its duly authorized agent, representative or officer; or when enclosed in a postage prepaid wrapper or envelope addressed to such person, firm or corporation at his, their or its Notice Address and deposited in a United States mailbox by registered or certified mail. To “Notify” means to give Notice. The Notice Addresses for the Owner and Contractor are stated in the Owner-Contractor Agreement and may be changed by a party by giving Notice to the other of such change.
- 1.1.9 **PLANS OR DRAWINGS:** All drawings or reproduction of drawings pertaining to the Work.
- 1.1.10 **PRODUCT:** The term Product includes materials, systems and equipment.
- 1.1.11 **PROJECT:** The Project is the total construction of which the Work performed under the Contract Documents may be the whole or a part.
- 1.1.12 **PROPOSAL:** A complete and properly signed document whereby the Contractor proposes to provide additional or a reduced scope of construction work on the Project for the sums stipulated therein, supported by data required by the Design Consultant or Owner.
- 1.1.13 **PROVIDE:** As a directive to the Contractor, and as pertaining to labor, materials or equipment, "provide" means "furnish and install completely".

- 1.1.14 SPECIFICATIONS: Descriptions, provisions and requirements, pertaining to method and manner of performing the Work, or to quantities and qualities of materials or equipment to be furnished under terms of the Contract.
- 1.1.15 WORK: The Work comprises the construction and services required of the Contractor by the Contract Documents and includes all labor, supplies and other facilities or things necessary to produce such construction, and all materials, equipment, and supplies incorporated or to be incorporated in such construction.
- 1.2 EXECUTION, CORRELATION AND INTENT
- 1.2.1 The Contractor and Owner acknowledge that neither these General Conditions, nor any other Contract Document shall be construed against the Owner due to the fact that they may have been drafted by the Owner or the Owner's agent. For the purposes of construing these General Conditions, and any other Contract Document, both the Contractor and the Owner shall be considered to have jointly drafted them.
- 1.2.2 The Owner-Contractor Agreement shall be signed in not less than three (3) copies by the Owner and Contractor, and each of which shall be deemed an original, but all of which shall constitute one and the same instrument.
- 1.2.3 By executing the Contract, the Contractor represents that he has visited the site, familiarized himself with the local conditions under which the Work is to be performed, and correlated his observations with the requirements of the Contract Documents.
- 1.2.4 The intent of the Contract Documents is to include all items necessary for the proper execution and completion of the Work. The Contract Documents are complementary, and what is required by any one shall be as binding as if required by all. Performance by the Contractor shall be required only to the extent consistent with the Contract Documents and reasonably inferable from them as being necessary to produce the intended results. Words and abbreviations which have well-known technical or trade meanings are used in the Contract Documents in accordance with such recognized meanings unless otherwise specifically defined herein. The table of contents, titles, headings, running headlines and marginal notes contained herein and in said documents are solely to facilitate reference to various provisions of the Contract Documents and in no way affect, limit or cast light upon the interpretation of the provisions to which they refer.
- 1.2.5 The organization of the Specifications into divisions, sections and articles, and the arrangement of Drawings are for convenience only. The Contractor may subcontract the Work in such divisions as he sees fit consistent with applicable law and he is ultimately responsible for furnishing all of the Work.
- 1.2.6 Anything shown on the Drawings and not mentioned in the Specifications or mentioned in the Specifications and not shown on the Drawings shall have the same effect as if shown or mentioned respectively in both. Detailed specifications take priority over general specifications and detailed drawings take precedence over general drawings. Any Work shown on one drawing shall be construed to be shown in all drawings. If any portion of the Contract Documents shall be in conflict with any other portion, the various documents comprising the Contract Documents shall govern in the following order of precedence: The Owner-Contractor Agreement; the Supplemental Conditions; the General Conditions; the Specifications; the Drawings. The Contractor shall notify the Design Consultant and the Owner of all such

inconsistencies promptly. Any such conflict or inconsistency between or in the Drawings or Specifications shall be submitted by the Contractor promptly to the Owner and Design Consultant and the Design Consultant's decision thereon shall be final and conclusive.

- 1.2.7 The Contractor agrees that nothing contained in the Contract Documents or any contract between the Owner and the Design Consultant shall create any contractual relationship between the Design Consultant and the Contractor, or between the Design Consultant and any Subcontractor or Sub-subcontractors. The Contractor acknowledges and agrees that this Contract is not intended to create, nor shall any provision be interpreted as creating, any contractual relationship between the Owner or Contractor and any third parties.
- 1.2.8 The provisions of this Contract cannot be amended, modified, varied or waived in any respect except by a Modification. The Contractor is hereby given notice that no person has authority to orally waive, or to release the Contractor from any of the Contractor's duties or obligations under or arising out of this Contract. Any waiver, approval or consent granted by Modification to the Contractor shall be limited to those matters specifically and expressly stated thereby to be waived, approved or consented to and shall not relieve the Contractor of the obligation to obtain any future waiver, approval or consent.
- 1.2.9 Any material or operation specified by reference to published specifications of a Manufacturer, a society, an association, a code, or other published standard, shall comply with requirements of the listed document which is current on date the Owner received bids for the construction of the Project. In case of a conflict between referenced document and the Specifications, Specifications shall govern. In case of a conflict between such listed documents, the one having more stringent requirements shall govern.
- 1.2.10 The Contractor, if requested, shall furnish an affidavit from each or any Manufacturer certifying that materials or products delivered to the job meets requirements specified.

1.3 OWNERSHIP AND USE OF DOCUMENTS

- 1.3.1 All Drawings, Specifications and copies thereof furnished by the Design Consultant are and shall remain the property of the Owner. They are to be used by Contractor only with respect to the Project and are not to be used by Contractor on any other project. With the exception of one contract set for each party to the Contract, such documents are to be returned or suitably accounted for to the Owner on request at the completion of the Work. Submission or distribution to meet official regulatory requirements or for other purposes in connection with the Project is not to be construed as publication in derogation of Owner's rights or the Design Consultant's common law copyright or other reserved rights.

ARTICLE 2

THE DESIGN CONSULTANT

2.1 DEFINITIONS

- 2.1.1 The term "Design Consultant" or "A/E" or "Architect" or "Engineer" as used or set forth in the Contract Documents, shall mean the entity and its consultants or agents, or their duly authorized representatives, that is responsible for designing or engineering the Work, and performing the activities specified herein, and in the Agreement for Design Consultant Services, including any consultants to said entity or firm acting within the scope of their agreements with the Design Consultant. Such firm or agency and its representatives shall act severally within the scope of

particular duties entrusted to them, unless otherwise provided for in the Contract Documents or in the Agreement for Design Consultant Services.

2.1.2 The Design Consultant may be identified in the Owner-Contractor Agreement and is referred to throughout the Contract Documents as if singular in number and masculine in gender. The Design Consultant is further described as and, throughout this document, shall mean one or both of the following:

2.1.2.1 ARCHITECT, a person or other legal entity lawfully licensed to practice architecture in the State wherein the Project is located; or

2.1.2.2 ENGINEER, a person or other legal entity lawfully licensed to practice engineering in the State wherein the Project is located.

2.2 SERVICES OF THE DESIGN CONSULTANT

2.2.1 The Design Consultant will provide certain services as hereinafter described and further described in the Agreement for Design Consultant Services.

2.2.2 Should errors, omissions, or conflicts in the Drawings, Specifications, or other Contract Documents prepared by or on behalf of the Design Consultant be discovered, the Design Consultant will prepare such amendments or supplementary documents and provide consultation as may be required.

2.2.3 The Design Consultant will visit the site at intervals appropriate to the stage of construction to familiarize itself generally with the progress and quality of the Work and to determine in general if the Work is proceeding in accordance with the Contract Documents. The Design Consultant will not be required to make exhaustive or continuous on-site inspections to check the quality or quantity of the Work, but it shall make as many inspections as may reasonably be required to fulfill its obligations to the Owner. On the basis of such on-site observations, the Design Consultant and his consultants shall endeavour to guard the Owner against defects and deficiencies in the Work. The Design Consultant will conduct the weekly construction meeting and shall be responsible for preparing accurate and complete minutes of all such meetings and other Project meetings and distributing same to all participants.

2.2.4 The Design Consultant will render written field reports to the Owner in the form required by the Owner relating to the periodic visits and inspections of the Project required by Paragraph 2.2.3.

2.2.5 The Design Consultant will not be responsible for and will not have control or charge of construction means, methods, techniques, sequences or procedures, or for safety precautions and programs in connection with the Work, and he will not be responsible for the Contractor's failure to carry out the Work in accordance with the Contract Documents. The Design Consultant will not be responsible for or have control or charge over the acts or omissions of the Contractor, Subcontractors, or any of their agents or employees, or any other persons performing any portion of the Work.

2.2.6 The Design Consultant shall at all times have access to the Work wherever it is in preparation or progress. The Contractor shall provide safe facilities for such access so the Design Consultant may perform his functions under the Contract Documents.

2.2.7 As required, the Design Consultant will render to the Owner, within a reasonable time,

- interpretations concerning the design and other technical aspects of the Work and the Contract Documents.
- 2.2.8 All communications, correspondence, submittals, and documents exchanged between the Design Consultant and the Contractor in connection with the Project shall be copied to the Owner, unless the Owner provides otherwise. Further, all communications, correspondence, submittals and documents transmitted from the Owner or Design Consultant will be directed to the Contractor and copied to the Owner or Design Consultant.
- 2.2.9 All interpretations and decisions of the Design Consultant shall be consistent with the intent of and reasonably inferable from the Contract Documents.
- 2.2.10 The Design Consultant's decisions in matters relating to artistic effect will be final if consistent with the intent of the Contract Documents.
- 2.2.11 If the Design Consultant observes any Work that does not conform to the Contract Documents, the Design Consultant shall report this observation to the Owner. The Design Consultant will prepare and submit to the Owner "punch lists" of the Contractor's work, which is not in conformance with the Contract Documents. The Owner will transmit such "punch lists" to the Contractor.
- 2.2.12 The Design Consultant has the authority to condemn or reject any or all of the Work on behalf of the Owner when, in its opinion, the Work does not conform to the Contract Documents. Whenever, in the Design Consultant's reasonable opinion, it is considered necessary or advisable for the implementation of the intent of the Contract Documents, the Design Consultant will have the authority to require special inspection or testing of any portion of the Work in accordance with the provisions of the Contract Documents whether or not such portion of the Work be then fabricated, installed or completed.
- 2.2.13 The Design Consultant will review the Contractor's submittals such as Shop Drawings, Product Data and Samples, but only for conformance with the design concept of the Work and for general compliance with the Contract Documents. Such action shall be taken within fourteen (14) days of receipt unless otherwise authorized by the Owner.
- 2.2.14 The Owner will establish with the Design Consultant procedures to be followed for review and processing of all Shop Drawings, catalogue submittals, project reports, test reports, maintenance manuals, and other necessary documentation, as well as requests for changes and applications for extensions of time.
- 2.2.15 The Design Consultant will prepare Change Orders and Construction Change Directives when requested by the Owner.
- 2.2.16 The Design Consultant and the Owner will conduct inspections to determine the dates of Substantial Completion and Final Completion. The Design Consultant will issue a final Certification of Payment.
- 2.2.17 The Design Consultant will prepare three (3) printed copies and one (1) electronic computer file compatible with the latest version of AutoCAD, or other program designated by Owner, showing significant Changes in the Work made during the construction process, based on neatly and clearly marked-up Drawings, prints, and other data furnished by the Contractor(s) and the applicable Addenda, clarifications and Change Orders which occurred during the Project. The Design Consultant will also provide the Owner assistance in the original operation of any

equipment or system such as initial start-up, testing, adjusting, and balancing.

- 2.2.18 In case of the termination of the employment of the Design Consultant, the Owner may appoint a Design Consultant whose status under the Contract Documents shall be that of the former Design Consultant.

ARTICLE 3

OWNER

3.1 DEFINITION

- 3.1.1 The Owner is the person or entity identified as such in the Owner-Contractor Agreement and may be referred to throughout the Contract Documents as if singular in number and masculine in gender. The term Owner means the Owner or his authorized representative or agent. The phrase "Owner or its agent" as used in this Agreement, does not include the Separate Contractors or their Subcontractors.

3.2 INFORMATION, SERVICES AND RIGHTS OF THE OWNER

- 3.2.1 The Owner will provide administration of the Contract as herein described. The Design Consultant shall also provide aspects of administration of the Contract as herein described or as specified in the Agreement for Design Consultant Services.
- 3.2.2 The Owner shall at all times have access to the Work whenever it is in preparation or progress. The Contractor shall provide safe facilities for such access.
- 3.2.3 The Owner shall not be responsible for or have control or charge of the construction means, methods, techniques, sequences, or procedures, or for safety precautions and programs in connection with the Work, and will not be responsible for the Contractor's failure to carry out the Work in accordance with the Contract Documents.
- 3.2.4 The Owner will have authority to require special inspection or testing of portions of the Work to the same extent as the Design Consultant in accordance with Paragraph 2.2.12 whether or not such portion of the Work be then fabricated, installed, or completed. However, neither the Owner's authority to act under Paragraph 3.2.4, nor any decision made by the Owner in good faith either to exercise or not to exercise such authority shall give rise to any duty or responsibility of the Owner to the Contractor, any Subcontractor, any of their agents or employees, or any other person performing any of the Work.
- 3.2.5 The Owner shall have the authority and discretion to call, schedule, and conduct job meetings to be attended by the Contractor, representatives of his Subcontractors, and the Design Consultant, to discuss such matters as procedures, progress, problems, and scheduling.
- 3.2.5.1 The Contractor is requested and required to attend weekly job site progress conferences as called by the Design Consultant. The Contractor shall be represented at these job progress conferences by project personnel authorized by the Contractor to make schedule and financial decision and by project personnel representatives. These meetings shall be open to Subcontractors, Material Suppliers, and any others who can contribute shall be encouraged by the Contractor to attend. It shall be the principal purpose of these meetings, or conferences, to affect coordination, cooperation and assistance in every practical way toward the end of maintaining progress of the Project on schedule and to complete the Project within the specified Contract Time. The

Contractor shall be prepared to assist progress of the Work as required in his particular contract and to recommend remedial measures for the correction of progress as may be appropriate. The Design Consultant shall be the coordinator of the conferences and shall preside as chairman.

- 3.2.5.2 If the Project is awarded as a single prime construction contract, the Design Consultant shall determine which, if any, Subcontractors and/or Material Suppliers shall be required to attend weekly job site progress conferences. The Contractor shall comply with this request and the meeting shall be conducted as described in Subparagraph 3.2.5.1.
- 3.2.6 The Owner will establish procedures to be followed for processing all Shop Drawings, catalogues, and other project reports, and other documentation, test reports, and maintenance manuals.
- 3.2.7 The Owner and Design Consultant will review all requests for changes and shall implement the processing of Change Orders, including applications for extension of the Contract Time.
- 3.2.8 The Owner, will not be responsible for the failure of the Contractor to plan, schedule, and execute the Work in accordance with the approved schedule or the failure of the Contractor to meet scheduled Completion Dates or the failure of the Contractor to schedule and coordinate the Work of his own trades and Subcontractors or to coordinate and cooperate with any Separate Contractors.
- 3.2.9 The Owner, in consultation with the Design Consultant, will review and process all Applications for Payment by the Contractor, including the final Application for Payment.
- 3.2.10 The Owner and Design Consultant shall not be responsible or liable to Contractor for the acts, errors or omissions of the Contractor, Subcontractors, or their agents or employees, or any other persons performing any of the Work or working on the Project.
- 3.2.11 The Owner shall furnish surveys describing the physical characteristics and legal limitations for the site of the Project, which are in its possession and are relevant to the Work.
- 3.2.12 The Owner shall secure and pay for necessary easements, required for permanent structures or for permanent changes in existing facilities.
- 3.2.13 The Owner shall furnish information or services under the Owner's control with reasonable promptness to avoid unreasonable delay in the orderly progress of the Work.
- 3.2.14 Unless otherwise provided in the Contract Documents, the Contractor will be furnished, free of charge, copies of Drawings and Specifications in accordance with the Supplemental Conditions.
- 3.2.15 The Owner will make reasonable efforts to make available for the Contractor's reasonable review, at the Owner's offices or together with the Contract Documents, certain boring logs, geotechnical, soils and other reports, surveys and analyses pertaining to the Project site of which the Owner is aware, has in its possession and are relevant to the Work. Any boring logs that are provided to the Contractor are only intended to reflect conditions at the locations of the borings and do not necessarily reflect site conditions at other locations. Any reports, surveys and analyses provided by Owner are for the Contractor's information only, and their accuracy and completeness are not guaranteed or warranted by the Owner or the Design Consultant, and such reports are not adopted by reference into, nor are they part of the Contract Documents. Notwithstanding any factual statement, conclusion, or any language or recommendations contained in such reports, the Contractor shall not rely upon the accuracy or completeness of

any reports surveys and analyses.

3.2.16 The foregoing rights are in addition to other rights of the Owner enumerated herein and those provided by law.

3.3 OWNER'S RIGHT TO STOP OR TO SUSPEND THE WORK

3.3.1 If the Contractor fails to correct defective Work as required by Section 13.2 or fails to carry out the Work or supply labor and materials in accordance with the Contract Documents, the Owner by a written Notice may order the Contractor to stop the Work, or any portion thereof, until the cause for such order has been eliminated; however, this right of the Owner to stop the Work shall not give rise to any duty on the part of the Owner to exercise this right for the benefit of the Contractor or any other person or entity.

3.3.2 The Owner may order the Contractor in writing to suspend, delay, or interrupt all or any part of the Work for such period of time as he may determine to be appropriate for the convenience of the Owner.

3.3.3 If the performance of all or any part of the Work (including the work of the Contractor and its Subcontractors) is, for an unreasonable period of time, suspended, delayed, or interrupted by an act of the Owner or the Design Consultant, or by failure of any one of them to act within the time specified in this Contract (or if no time is specified, within a reasonable time), an adjustment shall be made for an increase in the actual time required for performance of the Work by the Contractor, due solely to such unreasonable suspension, delay, or interruption and the Contract modified in writing accordingly. However, no Claim shall be made under this Paragraph for any suspension, delay, or interruption pursuant to Paragraph 3.4.1, or for which Claim is provided or excluded under any other provision of this Contract. No Claim under this Paragraph shall be allowed on behalf of the Contractor or its Subcontractors, unless within twenty (20) days after the act or failure to act involved, and for continuing or ongoing acts or failures to act within twenty (20) days of the first day of the act or failure to act, the Contractor submits to the Owner a written statement setting forth, as fully as then practicable, the extent of such Claim, and unless the Claim is asserted in writing within thirty (30) days after the termination of such suspension, delay, or interruption. For continuing or ongoing acts or failures to act, the Contractor shall update its written statement every twenty (20) days until the suspension, delay or interruption is terminated. The Contractor shall waive any and all Claims under this Paragraph 3.3.3 which are not filed in strict conformance with Paragraph 3.3.3. The Contractor shall indemnify, defend and hold the Owner harmless from any Claim by a Subcontractor that is waived because it is not filed in strict conformance with this Paragraph 3.3.3 or any other provision of the Contract regarding Claims.

3.3.4 In the event of a suspension of the Work or delay or interruption of the Work per Paragraph 3.3.3, the Contractor will and will cause his Subcontractors to protect carefully his, and their, materials and Work against damage, loss or injury from the weather and maintain completed and uncompleted portions of the Work as required by the Contract Documents. If, in the opinion of the Owner, any Work or material shall have been damaged or injured by reason of failure on the part of the Contractor or any of his Subcontractors to so protect same, such Work and materials shall be removed and replaced at the expense of the Contractor.

3.3.5 No Claim by the Contractor under Paragraph 3.3.3 shall be allowed if asserted after final payment under this Contract or if it is not asserted in strict conformance with Paragraph 3.3.3.

3.4 OWNER'S RIGHT TO CARRY OUT THE WORK

- 3.4.1 If the Contractor defaults or otherwise neglects to carry out the Work in accordance with the Contract Documents and fails within ten (10) days after the date written Notice is given by the Owner, with a copy of such Notice sent to the Contractor's Surety, to commence and continue remedy of such default or neglect with diligence and promptness, the Owner may, without prejudice to any other remedy he may have, make good such deficiencies and may further elect to complete all Work thereafter through such means as the Owner may select, including the use of a new contractor pursuant to Paragraph 3.4.2. In such case, the Owner shall provide Notice to the Contractor's Surety and an appropriate Change Order shall be issued deducting from the payments then or thereafter due the Contractor the cost of correcting such deficiencies, including compensation for the Design Consultant's additional services made necessary by such default, neglect or failure and any other damages suffered by Owner as a result of Contractor's breach, including but not limited to Owner's reasonable attorney's fees and litigation costs and expenses. If the payments then or thereafter due the Contractor are not sufficient to cover such amount, the Contractor or its Surety shall pay the difference to the Owner. Notwithstanding the Owner's right to carry out a portion of the Work, warranty, maintenance and protection of the Work remains the Contractor's and Surety's responsibility. Further, the provisions of this Paragraph do not affect the Owner's right to require the correction of defective or non-conforming Work in accordance with Section 13.2.
- 3.4.2 Whenever the Contractor shall be, and declared by the Owner to be in default under the Contract, the Owner having substantially performed Owner's obligations thereunder, the Surety shall promptly remedy the default, or shall be liable to Owner for damages pursuant to the Performance Bond and as provided by law. Any action by Surety or by Owner against the Surety shall not relieve Contractor of its duties, responsibilities and liabilities to Owner pursuant to the Contract or as allowed by law.

ARTICLE 4

CONTRACTOR

4.1 DEFINITION

- 4.1.1 The Contractor is the person or organization identified as such in the Owner-Contractor Agreement and may be referred to throughout the Contract Documents as if singular in number and masculine in gender. The term Contractor means the Contractor or his authorized representative, who shall have authority to bind the Contractor in all matters pertinent to the Contract.
- 4.1.2 The Contract is not one of agency by the Contractor for Owner but one in which Contractor is engaged independently in the business of providing the services and performing the Work herein described as an independent contractor.

4.2 REVIEW OF CONTRACT DOCUMENTS

- 4.2.1 The Contractor represents that prior to executing this Contract, the Contractor carefully reviewed and studied the Contract Documents and notified the Owner and Design Consultant of any errors, inconsistencies or omissions of which the Contractor is aware. The Contractor agrees to continuously and carefully study and compare the Contract Documents after the execution of this Contract and shall at once report to the Owner and Design Consultant any error, inconsistency or omission he may discover, including, but not limited to, any requirement which may be contrary to any law, ordinance, rule, regulation, building code, or order of any

public authority bearing on the Work. If the Contractor has reported in writing an error, inconsistency or omission, has promptly stopped the affected Work until otherwise instructed, and has otherwise followed the instructions of the Owner, the Contractor shall not be liable to the Owner or the Design Consultant for any damage resulting from any such errors, inconsistencies or omissions in the Contract Documents. The Contractor shall perform no portion of the Work at any time without it being specified in Contract Documents and, where required, approved Shop Drawings, Product Data or Samples for such portion of the Work.

4.2.2 The Contractor and his Subcontractors shall keep at the site of the Work at least one copy of the Drawings and Specifications and shall at all times give the Owner, the Design Consultant, inspectors, as well as other representatives of the Owner access thereto.

4.3 SUPERVISION AND CONSTRUCTION PROCEDURES

4.3.1 The Contractor shall supervise and direct the Work, using his best skill and attention. He shall be solely responsible for and have control over all construction means, methods, techniques, sequences and procedures and for coordinating all portions of the Work under the Contract.

4.3.1.1 It shall be the Contractor's responsibility to schedule the Work; to maintain a progress schedule for the Project; and to notify the Design Consultant and the Owner of any changes in the progress schedule. He shall be responsible for providing adequate notice to all Subcontractors to insure efficient continuity of all phases of the Project. The Contractor is responsible for keeping the Owner and Design Consultant fully informed as to the work progress, including immediate notification of any work progress changes.

4.3.2 The Contractor shall be responsible to the Owner for the acts and omissions of his employees, Subcontractors and Sub-subcontractors, Suppliers, their agents and employees, and other persons performing any of the Work and for their compliance with each and every requirement of the Contract Documents, in the same manner as if they were directly contracted by the Contractor.

4.3.3 The Contractor shall not be relieved from his obligations to perform the Work in accordance with the Contract Documents either by the acts, failures to act or duties of the Owner or the Design Consultant in their administration of the Contract, or by inspections, tests or approvals (or the lack thereof) required or performed under Section 7.6 by persons other than the Contractor.

4.3.4 Before starting a section of the Work, the Contractor shall carefully examine all preparatory work that has been executed to receive his work to see that it has been completed in accordance with the Contract Documents. He shall check carefully, by whatever means are required, to ensure that his work and adjacent, related work will finish to proper and required standards for quality, contours, planes, and levels.

4.3.5 The Contractor understands and agrees that the Owner and Design Consultant will not be responsible for and will not have control or charge of construction means, methods, techniques, sequences or procedures, or for safety precautions and programs in connection with the Work, and they will not be responsible for the Contractor's failure to carry out the Work in accordance with the Contract Documents. The Owner and the Design Consultant will not be responsible for or have control or charge over the acts or omissions of the Contractor, Subcontractors, or any of their agents or employees, or any other persons performing any of the Work.

4.3.6 The Contractor shall not use or provide Subcontractor equipment, materials, methods or persons to which Owner and Design Consultant have a reasonable objection and shall remove no portion of the Work or stored materials from the site of the Work, except for defective Work the Contractor may be required to replace or repair as set forth herein.

4.3.7 The Contractor shall verify all grades, lines, levels and dimensions as indicated and shown on the Drawings and in the Specifications prior to beginning any portion of the Work and shall immediately report in writing any errors or inconsistencies to the Design Consultant before commencing that portion of the Work.

4.4. CONTRACTOR'S REPRESENTATIONS

4.4.1 By entering into this Contract with the Owner, the Contractor represents and warrants the following, together with all other representations and warranties in the Contract Documents:

- .1 That he is experienced in and competent to perform the type of work required and to furnish the Subcontractors, materials, supplies, equipment and services to be performed or furnished by him;
- .2 That he is financially solvent, able to pay his debts as they mature, and possessed of sufficient working capital to initiate and complete the Work required under the Contract;
- .3 That he is familiar with all Federal, State, County, municipal and department laws, ordinances, permits, regulations, building codes and resolutions which may in any way affect the Work or those employed therein, including but not limited to any special laws or regulations relating to the Work or any part thereof;
- .4 That such temporary and permanent Work required by the Contract Documents will be satisfactorily constructed and fit for use for its intended purpose and that such construction will not injure any person, or damage any property;
- .5 That he has carefully examined the Contract Documents and the site of the Work and that from his own investigations, he has satisfied himself and made himself familiar with: (1) the nature and location of the Work; (2) the character, quality and quantity of surface and subsurface materials likely to be encountered, including, but not limited to, all structures and obstructions on or at the Project site, both natural and man-made; (3) the character of equipment and other facilities needed for the performance of the Work; (4) the general and local conditions including without limitation its climatic conditions, the availability and cost of labor and the availability and cost of materials, tools and equipment; (5) the quality and quantity of all materials, supplies, tools, equipment, labor and professional services necessary to complete the Work in the manner required by the Contract Documents; and (6) all other matters or things which could in any manner affect the performance of the Work;
- .6 That he will fully comply with all requirements of the Contract Documents;
- .7 That he will perform the Work consistent with good workmanship, sound business practice, and in the most expeditious and economical manner consistent with the best interests of the Owner;
- .8 That he will furnish efficient business administration and experienced project management and supervision, and an adequate supply of workers, equipment, tools and

materials at all times;

- .9 That he has carefully reviewed the Work required and that the Work can be planned and executed in a normal and orderly sequence of Work and reasonably scheduled so as to ensure completion of the Work in accordance with the Contract Documents, allowing for normal and reasonably foreseeable weather, labor and other delays, interruptions and disruptions of the Work;
- .10 That he will complete the Work within the Contract Time and all portions thereof within any required Completion Dates;
- .11 That his Contract Sum is based upon the labor, materials, systems and equipment required by the Contract Documents, without exception; and
- .12 That he will make a good faith effort to utilize minority and Historically Underutilized Businesses (HUBs) as defined and required in N.C. Gen. Stat. 143-128.2 to -128.4, and as described in the Contract Documents.

4.5 LABOR AND MATERIALS

- 4.5.1 Unless otherwise provided in the Contract Documents, the Contractor shall provide and pay for all labor, materials, equipment, supplies, tools, construction equipment and machinery, water, heat, utilities, transportation, and other facilities and services necessary or proper for or incidental to the execution and completion of the Work required by and in accordance with the Contract Documents and any applicable code or statute, whether specifically required by the Contract Documents or whether their provision may reasonably be inferred as necessary to produce the intended results, whether temporary or permanent and whether or not incorporated or to be incorporated in the Work. Final payment will not be made until the Work is so completed and Contractor has otherwise complied with the Contract Documents in full.
- 4.5.2 The Contractor shall at all times enforce strict discipline and good order among his employees and Subcontractors performing any of the Work and shall not employ or contract with on the Work any unfit person or entity or anyone not skilled in the task assigned to him. The Owner may, by Notice, require the Contractor to remove from the Work any employee or employee of a Subcontractor performing any of the Work, that the Owner deems incompetent, careless or otherwise objectionable.
- 4.5.3 The Contractor shall be responsible for ensuring that the Work is completed in a skilful and workmanlike manner.
- 4.5.4 All equipment, apparatus and/or devices of any kind to be incorporated into the Work that are shown or indicated on the Drawings or called for in the Specifications or required for the completion of the Work shall be entirely satisfactory to the Owner and the Design Consultant as regards operations, capacity and/or performance. No approval, either written or verbal, of any drawings, descriptive data or samples of such equipment, apparatus and/or device shall relieve the Contractor of his responsibility to turn over the same in good working order for its intended purpose at the completion of the Work in complete accordance with the Contract Documents. Any equipment, apparatus and/or device not fulfilling these requirements shall be removed and replaced by proper and acceptable equipment, etc. or put in good working order satisfactory to the Owner and Design Consultant without additional cost to the Owner.

4.6 WARRANTY

- 4.6.1 The Contractor warrants to the Owner and the Design Consultant that all materials and equipment furnished under this Contract will be new unless otherwise specified, and that all workmanship will be in accordance with generally accepted industry standards, free from faults and defects and in conformance with the Contract Documents and all other warranties and guaranties specified therein. Where no standard is specified for such workmanship or materials, they shall be the best of their respective kinds. All Work not conforming to these requirements, including substitutions not properly approved and authorized, may be considered defective. If required by the Owner or the Design Consultant, the Contractor shall furnish satisfactory evidence as to the kind and quality of materials and equipment. This warranty is not limited by the provisions of Article 13.
- 4.6.2 The Contractor will be required to complete the Work specified and to provide all items needed for construction of the Project, complete and in good order.
- 4.6.3 The warranties set forth in this Section 4.6 and elsewhere in the Contract Documents shall survive Final Completion of the Work under Section 9.9.
- 4.6.4 The Contractor guarantees and warrants to the Owner all Work as follows:
- .1 That all materials and equipment furnished under this Contract will be new and the best of its respective kind unless otherwise specified;
 - .2 That all Work will be in accordance with generally accepted industry standards and free of omissions and faulty, poor quality, imperfect and defective material or workmanship;
 - .3 That the Work shall be entirely watertight and leak proof in accordance with all applicable industry customs and practices, and shall be free of shrinkage and settlement;
 - .4 That the Work, including but not limited to, mechanical and electrical machines, devices and equipment, shall be fit and fully usable for its intended and specified purpose and shall operate satisfactorily with ordinary care;
 - .5 That consistent with requirements of the Contract Documents, the Work shall be installed and oriented in such a manner as to facilitate unrestricted access for the operation and maintenance of fixed equipment;
 - .6 That the Work will be free of abnormal or unusual deterioration which occurs because of poor quality materials, workmanship or unsuitable storage; and
 - .7 That the products or materials incorporated in the Work will not contain asbestos.
- 4.6.5 All Work not conforming to guarantees and warranties specified in the Contract Documents, including substitutions not properly approved and authorized, may be considered defective. If required by the Design Consultant or Owner, the Contractor shall furnish satisfactory evidence as to the kind and quality of materials and equipment.
- 4.6.5.1 The Contractor will submit a written affidavit certifying that none of the materials incorporated in the Project contain asbestos.

- 4.6.6 If, within one (1) year after the date of Substantial Completion of the Work or designated portion thereof as defined in Paragraph 8.1.3 or within such longer period of time as may be prescribed by law or by the terms of any applicable special warranty required by the Contract Documents, any of the Work is found to be defective, not in accordance with the Contract Documents, or not in accordance with the guarantees and warranties specified in the Contract Documents, the Contractor shall correct it within five (5) working days or such other period as mutually agreed, after receipt of Notice from the Owner to do so. The Owner shall give such Notice with reasonable promptness after discovery of the condition. For items that remain incomplete or uncorrected on the date of Substantial Completion, the one (1) year warranty shall begin on the date of Final Completion of the Work or upon correction of the defective Work.
- 4.6.7 If at any time deficiencies in the Work are discovered which are found to have resulted from fraud or misrepresentation, or an intent or attempt to or conspiracy to defraud the Owner by the Contractor, any Subcontractor or Supplier, the Contractor will be liable for replacement or correction of such Work and any damages which Owner has incurred related thereto, regardless of the time limit of any guarantee or warranty.
- 4.6.8 Any materials or other portions of the Work, installed, furnished or stored on site which are not of the character or quality required by the Specifications, or are otherwise not acceptable to the Design Consultant or the Owner, shall be immediately removed and replaced by the Contractor to the satisfaction of the Design Consultant and Owner, when notified to do so by the Design Consultant or Owner.
- 4.6.9 If the Contractor fails to correct defective or non-conforming Work as required by Paragraph 4.6.6, or if the Contractor fails to remove defective or non-conforming Work from the site, as required by Paragraph 4.6.8, the Owner may elect to either correct such Work in accordance with Section 3.4 or remove and store materials and equipment at the expense of the Contractor. If the Contractor does not pay the cost of such removal and storage within ten (10) days thereafter, the Owner may upon ten (10) additional days written Notice sell such Work at auction or at private sale and shall account for the net proceeds thereof, after deducting all the costs that should have been borne by the Contractor, including compensation for the Design Consultant's additional services and Owner's reasonable attorney's fees made necessary thereby. If such proceeds of sale do not cover all costs, which the Contractor should have borne, the difference shall be charged to the Contractor and an appropriate Change Order shall be issued. If the payments then or thereafter due the Contractor are not sufficient to cover such amount, the Contractor shall pay the difference to the Owner.
- 4.6.10 The Contractor shall bear the cost of making good all of the Work of the Owner, Separate Contractors or others, destroyed or damaged by such correction or removal required under this Article 4, Article 13 or elsewhere in the Contract Documents.
- 4.7 TAXES
- 4.7.1 The Contractor shall pay all sales, consumer, use and other similar taxes for the Work or portions thereof provided by the Contractor which are legally enacted at the time the Owner received bids for the construction of the Project, whether or not yet effective.
- 4.7.2 Sales and Use Tax. Contractor shall be responsible for complying with any applicable sales and use tax obligations imposed by Chapter 105, Article 5 of the North Carolina General Statutes. Where Contractor has been contracted with to oversee "new construction" or "reconstruction" as defined in G.S. 105-164.4H, Contractor shall be responsible for issuing and maintaining an Affidavit of Capital Improvement.

4.8 PERMITS, FEES AND NOTICES

- 4.8.1 The Owner shall be responsible for fees associated with permits and approval of the Drawings including but not limited to ~~building permit, utility impact fees~~, stormwater permit and driveway permit.
- 4.8.2 The Contractor is responsible for all fees, permits and other costs associated with temporary utilities, including but not limited to installation, use, disconnection, removal and/or relocation.
- 4.8.3 The Contractor will pay for his own license, inspection and re-inspection fees for the proper execution and completion of the Work.
- 4.8.4 The Contractor shall give all notices and comply with all laws, ordinances, rules, regulations and lawful orders of any public authority bearing on the performance of the Work, including but not limited to all applicable building codes. If Contractor believes that any part of the Drawings or Specifications are inconsistent with applicable laws, rules, regulations, lawful orders of public authorities or building codes, Contractor shall Notify the Owner and Design Consultant of such inconsistencies immediately.

4.9 ALLOWANCES

- 4.9.1 The Contractor shall include in the Contract Sum all Allowances stated in the Contract Documents. Items covered by these Allowances shall be supplied for such amount and by such persons as the Owner may direct, but the Contractor will not be required to employ persons against whom he makes a reasonable objection.
- 4.9.2 Unless otherwise provided in the Contract Documents:
- .1 Allowances for Work: These allowances shall cover the cost to the Contractor for the materials and equipment required by the allowance delivered at the site, all applicable taxes, unloading, uncrating and storage, protection from elements, labor, installation and finishing and other expenses and time required to complete the installation, and a fixed percentage for overhead and profit as defined in Article 12.
 - .2 Allowances for Products/Materials: Allowance includes the cost of the product, delivery to the site and applicable taxes. The Contractor's costs for unloading and handling on the site, labor, installation, time, overhead, profit and other expenses contemplated for the material allowance shall be included in the Contract Sum and not in the allowance;
 - .3 Whenever the cost is more than or less than the Allowance, the Contract Sum shall be adjusted accordingly by Change Order, the amount of which will recognize changes, if any, in handling costs on the site, labor, installation costs, overhead, profit and other expense.

4.10 SUPERINTENDENT

- 4.10.1 The Contractor shall employ, and have approved by the Owner, a competent superintendent and necessary assistants who shall be in attendance at the Project site during the progress of the Work. The superintendent shall represent the Contractor and all communications given to the superintendent shall be as binding as if given to the Contractor. If the Contractor employs more than a single individual in this role, the Owner shall be provided an organizational chart and

personnel listing for the staff performing the functions of a superintendent. In such event, all references to the superintendent elsewhere in the Contract Documents shall mean the staff performing the functions of a superintendent.

4.10.2 The superintendent shall be in attendance at the Project site not less than eight (8) hours per day, five (5) days per week, unless the job is closed down due to conditions beyond the control of the Contractor or until termination of the Contract in accordance with the Contract Documents. It is understood that such superintendent shall be acceptable to the Owner and shall be the one who will be continued in that capacity for the duration of the Project, unless he ceases to be on the Contractor's payroll or the Owner otherwise agrees. The superintendent shall not be employed on any other project for or by Contractor or any other entity during the course of the Work.

4.11 PROGRESS SCHEDULE

4.11.1 The Contractor shall prepare and submit to the Owner for the Owner's review and approval an estimated progress schedule for the Work.

4.12 RESPONSIBILITY FOR COMPLETION

4.12.1 The Contractor shall furnish such manpower, materials, facilities and equipment and shall work within the normal scheduled working hours to ensure the performance of the Work within the Completion Dates specified in the Owner-Contractor Agreement. If for any reason the Contractor must work outside of the normal scheduled working hours, a custodian employed by the Owner is required to be in attendance when accessing the work area. The Contractor agrees to reimburse the Owner for such custodian's time. The reimbursement is due with the subsequent payment application.

4.12.2 If it becomes apparent to the Design Consultant or Owner that the Work will not be completed within required Completion Dates, the Contractor agrees to undertake some or all of the following actions, at no additional cost to the Owner, in order to ensure, in the opinion of the Design Consultant and Owner, that the Contractor will comply with all Completion Date requirements:

- .1 Increase manpower, materials, crafts, equipment and facilities;
- .2 Increase the number of working hours per shift, shifts per working day, working days per week, or any combination of the foregoing, including but not limited to night shifts, overtime operations and Sundays and holidays;
- .3 Reschedule activities to achieve maximum practical concurrence of accomplishment of activities;
- .4 Require that his superintendent be at the Project site not less than ten (10) hours per day, six (6) days per week; and
- .5 Reimburse the Owner in accordance with Paragraph 4.12.1 above for all work performed outside of the normal scheduled work hours.

4.12.3 In undertaking the actions required under Paragraph 4.12.1, Contractor shall prepare and adhere to a recovery schedule if the Project is behind schedule by four (4) or more days.

- 4.12.4 If the actions taken by the Contractor are not satisfactory, the Design Consultant or Owner may direct the Contractor to take any and all actions necessary to ensure completion within the required Completion Dates, without additional cost to the Owner. In such event, the Contractor shall continue to assume responsibility for his performance and for completion within the required dates.
- 4.12.5 If, in the opinion of the Design Consultant or Owner, the actions taken by the Contractor pursuant to this Article or the progress or sequence of the Work are not accurately reflected on the construction schedule, the Contractor shall revise such schedule to accurately reflect the actual progress and sequence of the Work.
- 4.12.6 Failure of the Contractor to substantially comply with the requirements of this Article, may be considered grounds for a determination by the Owner, pursuant to Article 14, that the Contractor is failing to prosecute the Work with such diligence as will ensure its completion within the time specified.
- 4.12.7 The Owner may, at its sole discretion and for any reason, other than due to the fault of Contractor require the Contractor to accelerate the Work by providing overtime, Saturday, Sunday and/or holiday work and/or by having all or any Subcontractors designated by the Owner provide overtime, Saturday, Sunday, and/or holiday work. In the event that the Owner requires such acceleration a Change Order shall be issued in accordance with Article 12.
- 4.12.8 This Section 4.12 does not eliminate the Contractor's responsibility to comply with the local noise ordinances, all highway permit requirements and all other applicable laws, regulations, rules, ordinances, resolutions, and permit requirements.
- 4.12.9 The Contractor will provide the Owner assistance in the original operation of any equipment or system installed as Part of the Work, including initial start-up, testing, adjustment and balancing.
- 4.13 DOCUMENTS AND SAMPLES AT THE SITE
- 4.13.1 The Contractor shall maintain at the site for the Owner one record copy of all Drawings, Specifications, Addenda, Change Orders and other Modifications, in good order and marked currently to record all changes made during construction, and approved Shop Drawings, Product Data and Samples. These shall be delivered to the Design Consultant upon completion of the Work.
- 4.14 SHOP DRAWINGS, PRODUCT DATA AND SAMPLES
- 4.14.1 Shop Drawings are drawings, diagrams, schedules and other data specially prepared for the Work by the Contractor or any Subcontractor, Manufacturer, Supplier or distributor to illustrate some portion of the Work.
- 4.14.2 Product Data are illustrations, standard schedules, performance charts, instructions, brochures, diagrams and other information furnished by the Contractor to illustrate a material, product or system for some portion of the Work.
- 4.14.3 Samples are physical examples, which illustrate materials, equipment or workmanship and establish standards by which the Work will be judged.
- 4.14.4 Manuals are manufacturer's installation, start-up, operating, and maintenance and repair

instructions together with parts lists, pictures, sketches and diagrams, which set forth the manufacturer's requirements for the benefit of the Contractor and the Owner.

- 4.14.5 The Contractor shall prepare or have prepared at its expense and shall review, indicate approval thereupon, and submit, with reasonable promptness and in such sequence as to cause no delay in the Work or in the other work of the Owner or any Separate Contractor, all Shop Drawings, Product Data, Manuals and Samples required by the Contract Documents.
- 4.14.5.1 Unless otherwise directed in writing, the Contractor shall submit no less than three (3) copies of each Shop Drawing, Product Data, or Manuals to the Design Consultant. Routing of said submittals will be from the Contractor to the Design Consultant with a copy of the transmittal to the Owner. The Design Consultant will return one (1) copy of the reviewed submittal to the Contractor.
- 4.14.5.2 Where the Contract calls for the submittal of manufacturer's data to the Design Consultant for information only, such submittals shall be made before the commencement of any portion of the Work requiring such submission. Work performed without benefit of approved Shop Drawings for any portion of the Work is subject to removal and replacement at no cost to the Owner.
- 4.14.5.3 For standard manufactured items not requiring special Shop Drawings for manufacture, Contractor shall submit no less than three (3) copies of Manufacturer's catalogue sheets showing illustrated cuts of item to be furnished, scale details, sizes, dimensions, performance characteristics, capacities, wiring diagrams and controls, and all other pertinent information. One (1) copy of reviewed submissions will be returned to the Contractor.
- 4.14.5.4 Unless otherwise directed in writing, all other Shop Drawings, Contractor shall submit no less than three (3) legible copies of each drawing. Each drawing shall have a clear space for stamps. When phrase "by others" appears on Shop Drawings, the Contractor shall indicate on the Shop Drawing who is to furnish material or operations so marked before submittal. When the Shop Drawings are checked "revise and resubmit", the Contractor shall make corrections and submit new copies for review. The Shop Drawings shall contain the Contractor's "approval" and corrections.
- 4.14.5.5 For use of all trades, the Contractor shall provide such number of Shop Drawings as is required for field distribution.
- 4.14.5.6 The Design Consultant will review submittals and make marks to indicate corrections or revisions required and will stamp each submittal with an action stamp and will mark the stamp with the action required by the Contractor.
- 4.14.5.7 Contractor shall submit names of proposed Manufacturers, Material Suppliers, dealers, who are to furnish materials, fixtures, appliances or other fittings for approval as early as possible, to afford proper investigation and checking.
- 4.14.5.8 Transactions with manufacturers, or Subcontractors, shall be through Contractor.
- 4.14.5.9 Unless otherwise specified, Contractor shall submit samples in duplicate of adequate size showing quality, type, color range, finish, and texture as indicated in the Specifications.
- 4.14.5.10 Where Specifications require manufacturer's printed installation instructions, Contractor shall submit duplicate copies of such instructions for approval.

- 4.14.5.11 When several materials are specified by name for one use, Contractor shall select for use any of those so specified.
- 4.14.5.12 Whenever item or class of material is specified exclusively by trade name, manufacturer's name, or by catalogue reference, Contractor shall use only such item, unless written approval for substitution is secured, as outlined in the Specifications and in Section 4.15 of the General Conditions.
- 4.14.5.13 Contractor shall not order materials until receipt of written approval. Contractor shall furnish materials equal in every respect to approved samples.
- 4.14.6 By approving and submitting Shop Drawings, Product Data, Manuals and Samples, the Contractor represents that he has determined and verified all materials, field measurements, and field construction criteria related thereto, and that he has checked and coordinated the information contained within such submittals with the requirements of the Work and of the Contract Documents. The Contractor shall adhere to any supplementary processing and scheduling instructions pertaining to Shop Drawings, which may be issued by the Design Consultant.
- 4.14.6.1 Parts and details not fully indicated on the Drawings shall be detailed by the Contractor in accordance with standard engineering practice. Dimensions on the Drawings, as well as detailed drawings themselves are subject in every case to measurements of existing, adjacent, incorporated and completed, which shall be taken by the Contractor before undertaking any Work dependent on such data.
- 4.14.7 The Contractor shall not be relieved of responsibility for any deviation from the requirements of the Contract Documents by the Design Consultant's review of Shop Drawings, Product Data, Samples or Manuals under Paragraph 2.2.14 unless the Contractor has specifically informed the Design Consultant in writing of such deviation at the time of submission and the Design Consultant has given written approval to the specific deviation. The Contractor shall not be relieved from responsibility to Owner for errors or omissions in the Shop Drawings, Product Data, Samples, or Manuals by virtue of the Design Consultant's review or approval thereof.
- 4.14.8 The Contractor shall make corrections required by the Design Consultant and shall resubmit the required number of corrected copies of Shop Drawings or new Product Data or Samples. The Contractor shall direct specific attention, in writing on resubmitted Shop Drawings, Product Data or Samples or Manuals, to revisions other than those requested by the Design Consultant on previous submittals. Re-submittals necessitated by required corrections due to Contractor's errors or omissions shall not be cause for extension of Contract Time or an increase in the Contract Sum.
- 4.14.8.1 No portion of the Work requiring submission of Shop Drawings, Product Data, Samples or Manuals shall be commenced until the submittal has been approved by the Design Consultant as provided in Article 2. All such portions of the Work shall be in accordance with approved submittals.
- 4.14.9 Shop Drawings, Product Data and Samples shall be dated and shall bear the name of the Project; a description or the names or equipment, materials and items; and complete identification of locations at which materials or equipment are to be installed. Shop Drawings shall be stamped and signed stating that the Contractor has determined and verified all materials, field measurements, and field construction criteria related thereto and that he has checked and

coordinated the information contained within such submittals with the requirements of the Work and of the Contract Documents.

4.14.10 Submittals of Shop Drawings, Product Data, Samples or Manuals shall be accompanied by a transmittal letter, in duplicate, containing the name of the Project, the Contractor's name, the number of Shop Drawings, Product Data, Samples, or Manuals, identification of Specification section and other pertinent data.

4.15 EQUAL PRODUCTS AND SUBSTITUTIONS

4.15.1 All materials, supplies and articles furnished under the Contract shall, whenever specified and otherwise practicable, be the standard products of recognized, reputable manufacturers. Unless otherwise specifically provided in the Contract Documents, the naming of a certain brand, make, manufacturer or article, device, product, material, fixture or type of construction shall convey the general style, type, character and standard of quality of the article desired and shall not be construed as limiting competition. The Contractor, in such cases, may with Owner's written approval, use any brand, make, manufacturer, article, device, product, material, fixture, form or type of construction which in the judgment of the Design Consultant is equal to that specified. An item may be considered equal to the item so named or described if, in the opinion of the Owner and Design Consultant (1) it is at least equal in quality, durability, appearance, strength, and design; (2) it will perform at least equally the specific function imposed by the general design for the Work being contracted for or the material being purchased; and (3) it conforms substantially, even with deviations, to the detailed requirements for the item in the Specifications. Approval by the Owner and Design Consultant will be granted based upon considerations of quality, workmanship, economy of operation, suitability for the purpose intended, warranty and acceptability for use on the Project.

4.15.2 To obtain such approval on makes or brands of material other than those specified in Contract Documents, and not previously approved at the time the Owner received bids for the construction of the Project, the Contractor's request for approval of any substitution shall include:

- .1 Complete data substantiating compliance of the proposed substitution with the Contract Documents;
- .2 Product identification including manufacturers' name, address, and phone number;
- .3 Manufacturer's literature showing complete product description, performance and test data, and all reference standards;
- .4 Samples and colors in the case of articles or products;
- .5 Names and addresses of similar projects on which the product was used and date of installation;
- .6 For construction methods, include a detailed description for the proposed method and drawings illustrating same;
- .7 Itemized comparison of proposed substitution with product or method specified and any cost reduction, which shall benefit the Owner;
- .8 Accurate cost data on proposed substitution in comparison with product or method

specified;

- .9 All directions, specifications, and recommendations by manufacturers for installation, handling, storing, adjustment, and operation; and
- .10 Item by item comparison of characteristics of substitution item with those items specified.

4.15.3 The Contractor shall also submit with his request for approval a sworn and notarized statement which shall include all of the following representations by the Contractor, namely that:

- .1 He has investigated the proposed product or method and determined that it is equal or better in all respects to that specified and that it fully complies with all requirements of the Contract Documents;
- .2 He will meet all contract obligations with regard to this substitution;
- .3 He will coordinate installation of accepted substitutions into the Work, making all such changes and any required schedule adjustments, at no additional cost to the Owner, as may be required for the Work to be complete in all respects;
- .4 He waives all Claims for additional costs and additional time related to substitutions, which consequently become apparent. He also agrees to hold the Owner harmless from Claims for extra costs and time incurred by other Subcontractors and suppliers, or additional services which may have to be performed by the Design Consultant, for changes for extra work that may, at some later date, be determined to be necessary in order for the Work to function in the manner intended in the Contract Documents;
- .5 He will provide the same warranty and guarantee, and perform any work required in accordance therewith, for the substitution that is applicable to the specified item for which the substitution is requested;
- .6 Material will be installed, handled, stored, adjusted, tested, and operated in accordance with the manufacturers' recommendation and as specified in the Contract Documents.
- .7 In all cases new materials will be used unless this provision is waived by Notice from the Owner or his Design Consultant, or unless otherwise specified in the Contract Documents;
- .8 All material and workmanship will be in every respect in accordance with that which, in the opinion of the Owner or Design Consultant, is in conformity with approved modern practice; and
- .9 He has provided accurate cost data on the proposed substitution in comparison with the product or method specified.

4.15.4 Subject to the provisions of any applicable laws, approval for substitutions or equal products shall be at the sole discretion of the Owner, shall be in writing to be effective, and the decision of the Owner shall be final. The Owner or Design Consultant may require tests of all materials proposed for substitution so submitted to establish quality standards, at the Contractor's expense. After approval of a substitution, if it is determined that the Contractor submitted defective information or data regarding the substitution upon which Owner's approval was based, and that unexpected or unanticipated extensive redesign or rework of the Project will be required in order to accommodate the substitution, or that the substituted item will not perform or function

as well as the specified item for which substitution was requested, the Contractor will be required to furnish the original specified item or obtain approval to use another substitution; the Contractor shall pay all costs, expenses or damages associated with or related to the unacceptability of such a substitution and the resultant utilization of another item and no time extension shall be granted for any delays associated with or related to such substitution.

4.15.5 If a substitution is approved, no further change in brand or make will be permitted unless satisfactory, written evidence is presented to and approved by the Owner that the manufacturer cannot make scheduled delivery of the approved substituted item. The Owner will not consider substitutions for approval if:

- .1 The proposed substitution is indicated or implied on the Contractor's Shop Drawing or product data submittal and has not been formally submitted for approval by the Contractor in accordance with the above-stated requirements, or
- .2 Acceptance of the proposed substitution will require substantial design revisions to the Contract Documents or is otherwise not acceptable to the Owner and Design Consultant.

4.15.6 Except as otherwise provided for by the provisions of any applicable laws, the Contractor shall not have any right of appeal from the decision of the Owner rejecting any materials submitted if the Contractor fails to obtain the approval for substitution under this Article.

4.16 USE OF SITE

4.16.1 The Contractor shall confine operations at the site to areas permitted by law, ordinances, permits, easements, right-of-way agreements and within the limits of construction as shown on the Contract Documents. The Contractor shall not unreasonably encumber the site, in the opinion of the Owner, with any materials, equipment or trailers nor shall he block the entrances or otherwise prevent reasonable access to the site, other working and parking areas, completed portions of the Work and/or properties, storage areas, areas of other facilities that are adjacent to the worksite. If the Contractor fails or refuses to move said material, equipment or trailers within twenty four (24) hours of notification by the Owner, to so do, the Owner shall have the right, without further notice, to remove, at the Contractor's expense, any material, equipment and/or trailers which the Owner deems are in violation of this Paragraph.

4.17 CUTTING AND PATCHING OF WORK

4.17.1 The Contractor shall be responsible for all cutting, fitting or patching that may be required to complete the Work or to make its several parts fit together properly and in accordance with the Contract Documents.

4.17.2 The Contractor shall not damage or endanger any portion of the Work or the work of the Owner or any Separate Contractors by cutting, patching or otherwise altering any work, or by excavation. The Contractor shall not cut or otherwise alter the work of the Owner or any Separate Contractor except with the written consent of the Owner and of such Separate Contractor. The Contractor shall not unreasonably withhold from the Owner or any Separate Contractor his consent to cutting or otherwise altering the Work. The Owner shall not be required to accept work with a cut, splice, or patch when such cut, splice or patch is not generally accepted practice for the particular work involved or is otherwise unworkmanlike in the opinion of the Design Consultant or the Owner.

4.17.3 Existing structures and facilities including but not limited to building, utilities, topography,

streets, curbs, walks, etc., that are damaged or removed due to required excavations or other construction work, shall be patched, repaired or replaced by the Contractor to satisfaction of the Design Consultant and the Owner of such structures and facilities and authorities having jurisdiction. In event the local jurisdictional authorities require that such repairing and patching be done with their own labor and materials, the Contractor shall abide by such regulations and pay for such work with no increase in the Contract Sum.

4.18 CLEANING UP

4.18.1 The Contractor at all times shall keep the premises free from accumulation of waste materials or rubbish caused by his operations. At the completion of the Work and before final payment is made, he shall remove all his waste materials and rubbish from and about the Project as well as all his tools, construction equipment, machinery and surplus materials.

4.18.2 If the Contractor fails to clean up during or at the completion of the Work, the Owner may do so as provided in Section 6.3 and the cost thereof shall be charged to the Contractor.

4.19 COMMUNICATIONS

4.19.1 All communications from the Contractor relating to the Contract Documents or the construction schedule will be directed to the Design Consultant and copied to the Owner. Similarly, all correspondence from the Owner or Design Consultant will be directed to the Contractor and copied to the Owner or Design Consultant.

4.20 ROYALTIES AND PATENTS

4.20.1 The Contractor shall pay all royalties and license fees. He shall defend all suits or claims for infringement of any patent rights arising out of the Work and shall save the Owner harmless from loss on account thereof.

4.21 INDEMNIFICATION

4.21.1 To the fullest extent permitted by law, the Contractor shall, at its sole cost and expense, indemnify, defend, and hold harmless the Owner and its agents, representatives, and employees from and against all claims, actions, judgments, costs, liabilities, penalties, damages, losses and expenses, including but not limited to attorneys' fees, arising out of and/or resulting from the performance of the Work, provided that any such claim, action, judgment, cost, liability, penalty, damage, loss or expense is caused by any negligent act, error or omission of the Contractor, any Subcontractor or anyone directly or indirectly employed by any of them or anyone for whose acts any of them may be legally liable. The above obligation shall not be construed to negate, abridge, or otherwise reduce any other right or obligation of indemnity which would otherwise exist as to any party or person described in this Section 4.21.1. The parties agree that this indemnification clause is an "evidence of indebtedness" for purpose of N.C. Gen. Stat. § 6-21.2. The parties also specifically acknowledge that the Owner is a public body and it is the intent of the parties that the Owner not incur any expenses when the Contractor is solely responsible for the claims.

4.21.2 In any and all claims against the Owner or the Design Consultant or any of their agents, representatives, or employees by any employee of the Contractor, any Subcontractor, anyone directly or indirectly employed by any of them or anyone for whose acts any of them may be liable, the indemnification obligation under this Section 4.21 shall not be limited in any way by any limitation on the amount or type of damages, compensation or benefits payable by or for

the Contractor or any Subcontractor under workers' or workmen's compensation acts, disability benefit acts or other employee benefit acts.

4.21.3 No provision of this Section 4.21 shall give rise to any duties on the part of the Design Consultant or the Owner, or any of their agents, representatives, or employees.

4.22 PERSONS AUTHORIZED TO SIGN DOCUMENTS

4.22.1 The Contractor, within five (5) days after the earlier of the date of a Notice to Proceed or the date of the Owner-Contractor Agreement, shall file with the Owner a list of all persons who are authorized to sign documents such as contracts, certificates, and affidavits on behalf of the Contractor and to fully bind the Contractor to all the conditions and provisions of such documents, except that in the case of a corporation he shall file with the Owner a certified copy of a resolution of the Board of Directors of the corporation in which are listed the names and titles of corporation personnel who are authorized to sign documents on behalf of the corporation and to fully bind the corporation to all the conditions and provisions of such documents.

4.23 CONDITIONS AFFECTING THE WORK

4.23.1 The Contractor shall be responsible for taking all steps necessary to ascertain the nature and location of the Work and the general and local conditions that can affect the Work or the cost thereof. Failure by the Contractor to fully acquaint himself with conditions which may affect the Work, including, but not limited to conditions relating to transportation, handling, storage of materials, availability of labor, water, roads, weather, topographic and subsurface conditions, Multi-Prime Contract conditions, applicable provisions of law, and the character and availability of equipment and facilities needed prior to and during the execution of the Work, shall not relieve the Contractor of his responsibilities under the Contract Documents and shall not constitute a basis for an adjustment in the Contract Sum or the Contract Time under any circumstances. The Owner assumes no responsibility for any understanding or representation about conditions affecting the Work made by any of his officers, employees, representatives, or agents prior to the execution of the Contract, unless such understandings or representations are expressly stated in the Contract Documents.

4.23.2 If in the execution of the Work any valuable items or materials of any kind are discovered buried or hidden within the Work, such items or materials shall be the property of the Owner. The Contractor shall take reasonable precautions to prevent any persons from removing or damaging such items or materials and shall immediately upon discovery thereof and before removal, acquaint the Owner or the Design Consultant with such discovery and carry out, at the expense of the Owner, the Owner's or the Design Consultant's orders as to disposal of the same.

4.24 COMPLIANCE WITH BOARD POLICIES AND PROCEDURES

The Contractor acknowledges that Board policies are available for review at the Owner's website and agrees to comply with the policies. The Contractor also agrees to comply with the following provisions:

4.24.1 The Contractor, its Subcontractors and employees shall not possess or carry, whether openly or concealed, any gun, rifle, pistol, or explosive on any property owned by the Owner. This includes firearms locked in containers, vehicles or firearm racks within vehicles. The Contractor, its Subcontractors and employees shall not cause, encourage or aid a minor, who

is less than 18 years old to possess or carry, whether openly or concealed, any weapons on any property owned by the Owner.

- 4.24.2 The Contractor, its Subcontractors and employees, are prohibited from profane, lewd, obscene or offensive conduct or language, including engaging in sexual harassment.
- 4.24.3 The Contractor and its Subcontractors shall not manufacture, transmit, conspire to transmit, possess, use or be under the influence of any alcoholic or other intoxicating beverage, narcotic drug, hallucinogenic drug, amphetamine, barbiturate, marijuana or anabolic steroids, or possess, use, transmit or conspire to transmit drug paraphernalia on any property owned by the Owner.
- 4.24.4 The Contractor and its Subcontractors may not at any time use or display tobacco or nicotine-containing products, including but not limited to electronic cigarettes (e-cigarettes), on school premises, both indoor and outdoor. The prohibition of the display of tobacco or nicotine products shall not extend to a display that has a legitimate instructional or pedagogical purpose. For purposes of this Contract, “tobacco product” is defined to include cigarettes, cigars, blunts, bidis, pipes, chewing tobacco, snuff, and any other items containing or reasonably resembling tobacco, tobacco products, or any facsimile thereof. “Tobacco use” includes smoking, chewing, dipping, or any other use of tobacco products.
- 4.24.5 The Contractor, its Subcontractors and employees shall not solicit from or sell to students or staff within the Owner’s facilities or campuses, and shall not give gifts of any value to school system employees.
- 4.24.6 Operators of all commercial vehicles on any property owned by the Owner shall be subject to post-accident, random, reasonable suspicion and follow-up testing for drugs and alcohol.
- 4.24.7 The Contractor, its Subcontractors and employees are prohibited from using access to the site pursuant to this Agreement as a means to date, court, or enter into a romantic or sexual relationship with any student enrolled in the Owner’s schools. The Contractor agrees to indemnify the Owner for claims against the Owner resulting from relationships which have occurred or may occur between a student and an employee of the Contractor or Subcontractor.
- 4.24.8 Lunsford Act/Criminal Background Checks. The Contractor shall conduct at its own expense sexual offender registry checks on each of its owners, employees, agents, or Subcontractors (“contractual personnel”) who will engage in any service on or delivery of goods to school system property or at a school-system sponsored event, except checks shall not be required for individuals who are solely delivering or picking up equipment, materials, or supplies at: (1) the administrative office or loading dock of a school; (2) non-school sites; (3) schools closed for renovation; or (4) school construction sites.. The checks shall include at a minimum checks of the State Sex Offender and Public Protection Registration Program, the State Sexually Violent Predator Registration Program, and the National Sex Offender Registry (“the Registries”). For the Contractor’s convenience only, all of the required registry checks may be completed at no cost by accessing the United States Department of Justice Sex Offender Public Website at [http:// www.nsopw.gov/](http://www.nsopw.gov/). The Contractor shall provide certification that the registry checks were conducted on each of its contractual personnel providing services or delivering goods under this Agreement prior to the commencement of such services or the delivery of such goods. The Contractor shall conduct a current initial check of the registries (a check done more than 30 days prior to the date of this Agreement shall not satisfy this contractual obligation).

In addition, Contractor agrees to conduct the registry checks and provide a supplemental certification before any additional contractual personnel are used to deliver goods or provide services pursuant to this Agreement. Contractor further agrees to conduct annual registry checks of all contractual personnel and provide annual certifications at each anniversary date of this Agreement. Contractor shall not assign any individual to deliver goods or provide services pursuant to this Agreement if said individual appears on any of the listed registries. Contractor agrees that it will maintain all records and documents necessary to demonstrate that it has conducted a thorough check of the registries as to each contractual personnel, and agrees to provide such records and documents to the school system upon request. Contractor specifically acknowledges that the school system retains the right to audit these records to ensure compliance with this Section at any time in the school system's sole discretion. Failure to comply with the terms of this provision shall be grounds for immediate termination of the Agreement. In addition, the Owner may conduct additional criminal records checks at the Owner's expense. If the school system exercises this right to conduct additional criminal records checks, Contractor agrees to provide within seven (7) days of request the full name, date of birth, state of residency for the past ten years, and any additional information requested by the school system for all contractual personnel who may deliver goods or perform services under this Agreement. Contractor further agrees that it has an ongoing obligation to provide the school system with the name of any new contractual personnel who may deliver goods or provide services under the Agreement. The Owner reserves the right to prohibit any contractual personnel of Contractor from delivering goods or providing services under this Agreement if the Owner determines, in its sole discretion, that such contractual personnel may pose a threat to the safety or well-being of students, school personnel or others.

- 4.24.9 Contractor shall not employ any individuals to provide services to the Owner who are not authorized by federal law to work in the United States. Contractor represents and warrants that it is aware of and in compliance with the Immigration Reform and Control Act and North Carolina law (Article 2 of Chapter 64 of the North Carolina General Statutes) requiring use of the E-Verify system for employers who employ twenty-five (25) or more employees and that it is and will remain in compliance with these laws at all times while providing services pursuant to this Agreement. Contractor shall also ensure that any of its Subcontractors (of any tier) will remain in compliance with these laws at all times while providing subcontracted services in connection with this Agreement. Contractor is responsible for providing affordable health care coverage to all of its full-time employees providing services to the School System. The definitions of "affordable coverage" and "full-time employee" are governed by the Affordable Care Act and accompanying IRS and Treasury Department regulations.
- 4.24.10 The Contractor, its Subcontractors and employees shall not interact with any students. Nothing in Paragraph 4.24 shall be construed to prevent the Contractor, its Subcontractors and employees from taking necessary measures to protect students, staff or other employees.
- 4.24.11 The Contractor shall at all times enforce strict discipline and good order among its employees and shall not employ any unfit person or anyone not skilled in the task assigned to it. The Owner may require the Contractor to remove any employee the Owner deems incompetent, careless or otherwise objectionable.
- 4.24.12 All agents and workers of the Contractor and its Subcontractors shall wear identification badges provided by the Contractor at all times they are on the Owner's property. The identification badges shall at a minimum display the company name, telephone number, employee name and

a picture of the employee.

- 4.24.13 The Contractor shall comply with the Owner's site or school building access procedures when working on any existing school campus.
- 4.24.14 Anti-Nepotism. Unless disclosed to the Owner in writing prior to the Board's approval and execution of the Agreement, the Contractor warrants that, to the best of its knowledge and in the exercise of due diligence, none of its corporate officers, directors, or trustees and none of its employees who will directly provide services under this Agreement are immediate family members of any member of the Owner's Board of Education or of any principal or central office staff administrator employed by the Owner. For purposes of this provision, "immediate family" means spouse, parent, child, brother, sister, grandparent, or grandchild, and includes step, half, and in-law relationships. Should Contractor become aware of any family relationship covered by this provision or should such a family relationship arise at any time during the term of this Agreement, Contractor shall immediately disclose the family relationship in writing to the Superintendent. Unless disclosed prior to the execution of the Agreement or formally waived by the Owner at a Board meeting, the existence of a family relationship covered by this Agreement is grounds for immediate termination by Owner without further financial liability to Contractor.
- 4.24.15 Restricted Companies Lists. Contractor represents that as of the date of this Agreement, Contractor is not included on the Final Divestment List created by the North Carolina State Treasurer pursuant to N.C. Gen. Stat. § 147-86.58. Contractor also represents that as of the date of this Agreement, Contractor is not included on the list of restricted companies determined to be engaged in a boycott of Israel created by the North Carolina State Treasurer pursuant to N.C. Gen. Stat. § 147-86.81.

ARTICLE 5

SUBCONTRACTORS

- 5.1 DEFINITION
- 5.1.1 A Subcontractor is a person or entity who has a direct contract with the Contractor to perform any of the Work at the site. The term Subcontractor may be referred to throughout the Contract Documents as if singular in number and masculine in gender and means a Subcontractor or his authorized representative. The term Subcontractor does not include any Separate Contractor or his subcontractors.
- 5.1.2 A Sub-subcontractor is a person or entity who has a direct or indirect contract with a Subcontractor to perform any of the Work at the site or who contracts to perform or supply any of the Work under the scope of a Subcontractor's subcontract. The term Sub-subcontractor may be referred to throughout the Contract Documents as if singular in number and masculine in gender and means a Sub-subcontractor or an authorized representative thereof.
- 5.1.3 Nothing contained in the Contract Documents is intended to, nor shall it create, any contractual relationship between the Owner, the Design Consultant, or any of their agents, consultants, employees, independent contractors, or representatives and any Subcontractor, Sub-subcontractor, Supplier or Vendor of the Contractor, except the relationship between Owner and Contractor, but the Owner shall be entitled to performance of all obligations intended for his benefit, and to enforcement thereof.

- 5.1.4 The Owner and Design Consultant will not deal directly with any Subcontractor, Sub-subcontractor or Material Supplier. Communication will be made only through the Contractor. Subcontractor, Sub-subcontractors or Material Suppliers shall route requests for information or clarification through the Contractor to the Design Consultant.
- 5.2 AWARD OF SUBCONTRACTS AND OTHER CONTRACTS FOR PORTIONS OF THE WORK
- 5.2.1 The Contractor, in compliance with the requirements of the Contract Documents and within ten (10) days after the Notice to Proceed, shall furnish in writing to the Owner the names of the persons or entities (including those who are to furnish materials or equipment fabricated to a special design) proposed for each of the principal portions of the Work. The Owner will promptly reply to the Contractor in writing stating whether or not the Owner, after due investigation, has reasonable objection to any such proposed person or entity. Failure of the Owner to reply within a reasonable time shall constitute notice of no reasonable objection. The Contractor understands and agrees that no contractual agreement exists for any part of the Work under this Contract between the Owner and any of the Contractor's Subcontractors or Sub-subcontractors. Further, the Contractor understands and agrees that he alone is responsible to the Owner for the Work under this Contract and that any review of Subcontractors or Sub-subcontractors by the Owner will not in any way make the Owner responsible to any Subcontractor, nor responsible for the actions or failures of any Subcontractor or Sub-subcontractor.
- 5.2.1.1 The Contractor shall identify in the list of names of the Subcontractors proposed, those Subcontractors that are minority or Historically Underutilized Businesses (HUBs) and indicate the portion of the Work that each Subcontractor will perform.
- 5.2.2 The Contractor shall not contract with any such proposed person or entity to whom the Owner has made reasonable objection under the provisions of Paragraph 5.2.1. The Contractor shall not be required to contract with anyone to whom he has a reasonable objection.
- 5.2.3 If the Owner has reasonable objection to any proposed person or entity under Paragraph 5.2.1, the Contractor shall name a substitute to whom the Owner has no reasonable objection. The Contract Sum shall be increased or decreased by the difference in cost occasioned by such substitution and an appropriate Change Order shall be issued, subject to an audit of said difference by the Owner; provided, however, that no increase in the Contract Sum shall be allowed for any such substitution unless the Contractor has acted promptly and responsively in submitting names as required by Paragraph 5.2.1 and the original proposed Subcontractor was: (i) able to carry out his work under his proposed subcontract, (ii) able to comply with all applicable laws, (iii) was an ongoing business in the field of his proposed subcontract, and (iv) had a labor force, capital and a means of supply compatible with the scope of his proposed subcontract.
- 5.2.4 If the Owner requires a change of any proposed Subcontractor or person or organization previously accepted by him on the Project, the Contract Sum shall be increased or decreased by the difference in cost occasioned by such change and an appropriate Change Order shall be issued, subject to an audit by Owner.
- 5.2.5 The Contractor shall notify the Owner and the Design Consultant of any substitution for any Subcontractor identified in accordance with Subparagraph 5.2.1.1. The Contractor shall make no substitution for any Subcontractor, person or entity previously selected if the Owner or the

Design Consultant makes reasonable objection to such substitution. Also, Contractor may make no substitution of Subcontractors in violation of applicable law.

5.2.6 If during the duration of the Project, the Contractor effects a substitution for any Subcontractor per Paragraph 5.2.5, or if additional subcontract opportunities become available, the Contractor shall make a good faith effort to utilize minority and Historically Underutilized Businesses (HUBs).

5.3 SUBCONTRACTUAL RELATIONS

5.3.1 By an appropriate written agreement, the Contractor shall require each Subcontractor, to the extent of the Work to be performed by the Subcontractor, to be bound to the Contractor by the terms of the Contract Documents, and to assume toward the Contractor all the obligations and responsibilities which the Contractor, by these Contract Documents, assumes toward the Owner. Said agreement shall preserve and protect the rights of the Owner under the Contract Documents with respect to the Work to be performed by the Subcontractor so that the subcontracting thereof will not prejudice such rights, and shall allow to the Subcontractor, unless specifically provided otherwise in the agreement between the Contractor and Subcontractor, the benefit of all rights, remedies and redress against the Contractor that the Contractor, by these Contract Documents, has against the Owner. Where appropriate, the Contractor shall require each Subcontractor to enter into similar agreements with his Sub-subcontractors. The Contractor shall make available to each proposed Subcontractor, prior to the execution of the subcontract, copies of the Contract Documents to which the Subcontractor will be bound by this Section 5.3, and identify to the Subcontractor any terms and conditions of the proposed Subcontract which may be at variance with the Contract Documents. Each Subcontractor shall similarly make copies of such Contract Documents available to his Sub-subcontractors.

5.3.2 The provisions herein regarding Subcontractor approvals shall in no way affect the liability of the Contractor to the Owner regarding performance of all obligations by or payment of Subcontractors. Approval to subcontract with any given Subcontractor shall not to any degree relieve the Contractor of his obligation to perform or have performed to the full satisfaction of the Owner the Work required by this Contract.

5.3.3 The Contractor shall submit Notice to the Owner of any Claims by Subcontractors for which the Owner is believed to be responsible, in strict conformance with the same time requirements and other procedures established for the submission of the Contractor's Claims to the Owner.

5.4 QUALIFICATION SUBMITTALS

5.4.1 Specific qualification submittals may be required of Subcontractors, installers and suppliers for certain critical items of the Work. Required qualification submittals are set forth in detail in the Specifications and shall be collected and submitted by the Contractor for review and approval by the Design Consultant. All information required of a single Subcontractor, installer or supplier shall be contained in a single, complete submittal. The Contractor shall submit the required qualification information within ten (10) days after receipt of the Design Consultant's request.

5.4.2 The Owner and Design Consultant shall reject any proposed Subcontractor, installer or supplier, or any qualification submittals related thereto, for the following reasons:

- .1 The Contractor's failure to submit requested information within the specified time; or

- .2 The Contractor's failure to provide all of the requested information; or
 - .3 The Contractor's submission of a Subcontractor, installer or supplier, or qualifications thereof, which are unacceptable in the judgment of the Owner or Design Consultant.
- 5.4.3 Should the Owner or Design Consultant have reasonable objection to any proposed Subcontractor, installer or supplier, the Contractor shall submit another person or firm who are reasonably acceptable to the Owner and Design Consultant.
- 5.5 PREPARATORY WORK
- 5.5.1 Before starting a portion of the Work, the Contractor and the responsible Subcontractor shall carefully examine all preparatory work that has been executed to receive his work. The Subcontractor shall check carefully, by whatever means are required, to ensure that his work and adjacent related work will finish to proper contours, planes and levels. He shall promptly notify the Contractor and the Design Consultant of any defects or imperfections in preparatory work, which will, in any way, affect satisfactory completion of his work. Absence of such notification will be construed as an acceptance of preparatory work and later Claims of defects therein will not be recognized.
- 5.5.2 Under no conditions shall a portion of the Work proceed prior to preparatory work having been completed, cured, dried, and otherwise made satisfactory to receive such related work. Responsibility for timely installation of all materials rests solely with the Contractor, who shall maintain coordination control at all times.

ARTICLE 6

WORK BY OWNER OR BY SEPARATE CONTRACTORS

- 6.1 OWNER'S RIGHT TO PERFORM WORK AND TO AWARD SEPARATE CONTRACTS
- 6.1.1 The Owner reserves the right to perform work related to the Project with his own forces, and to award separate contracts in connection with other portions of the Project or other work on the site under these or similar conditions of the Contract.
- 6.1.2 When separate contracts are awarded for different portions of the Project or other work on the site, the term Contractor in the Contract Documents in each case shall mean the Contractor who executes each separate Owner-Contractor Agreement.
- 6.2 MUTUAL RESPONSIBILITY
- 6.2.1 The Contractor shall afford Separate Contractors and the Owner reasonable opportunity for the introduction and storage of their materials and equipment and the execution of their work and shall properly connect and coordinate the Work with that of the Owner and other contractors to store his apparatus, materials, supplies and equipment in such orderly fashion at the site of the Work as will not unduly or unreasonably interfere with the progress of the Work or the work of any other contractors.
- 6.2.1.1 If the execution or result of any part of the Work depends upon any work of the Owner or of any Separate Contractor, the Contractor shall, prior to proceeding with the Work, inspect and promptly report to the Owner in writing any apparent discrepancies or defects in such work of

the Owner or of any Separate Contractor that render it unsuitable for such proper execution or result of any part of the Work.

- 6.2.1.2 Failure of the Contractor to so inspect and report shall constitute an acceptance of the Owner's or Separate Contractor's work as fit and proper to receive the Work, except as to defects which may develop in the Owner's or Separate Contractor's work after completion of the Work and which the Contractor could not have discovered by its inspection prior to completion of the Work.
- 6.2.2 Should the Contractor cause damage to the Work or property of the Owner or of any Separate Contractor on the Project, or to other work on the site, or delay or interfere with the Owner's work on ongoing operations or facilities or adjacent facilities or said Separate Contractor's work, the Contractor shall be liable for the same; and, in the case of another contractor, the Contractor shall attempt to settle said Claim with such other contractor prior to such other contractor's institution of litigation or other proceedings against the other contractor.
 - 6.2.2.1 Should a Separate Contractor be declared in default by the Owner, the Owner shall not be obligated to hire a contractor to perform the work of the Separate Contractor during the time the Separate Contractor's surety is remedying the default pursuant to Paragraph 3.4.2.
 - 6.2.2.2 If such Separate Contractor sues the Owner or Design Consultant on account of any damage, delay or interference cause or alleged to have been caused by the Contractor, the Owner shall notify the Contractor, who shall defend the Owner and Design Consultant in such proceedings at the Contractor's expense. If any judgment or award is entered against the Owner or Design Consultant in such proceedings, the Contractor shall satisfy the same and shall reimburse the Owner and Design Consultant for all damages, expenses, attorney's fees and other costs which the Owner or Design Consultant incurs as a result thereof.
- 6.2.3 Should a Separate Contractor cause damage to the Work or to the property of the Contractor or cause delay or interference with the Contractor's performance of the Work, the Contractor shall present directly to said Separate Contractor any Claims it may have as a result of such damage, delay or interference (with an information copied to the Owner) and shall attempt to settle its Claim against said Separate Contractor prior to the institution of litigation or other proceedings against said Separate Contractor.
 - 6.2.3.1 In no event shall the Contractor seek to recover from the Owner or the Design Consultant, and the Contractor hereby waives any Claims against the Owner and Design Consultant relating to any costs, expenses (including, but not limited to, attorney's fees) or damages or other losses incurred by the Contractor as a result of any damage to the Work or property of the Contractor or any delay or interference caused by any Separate Contractor.
- 6.2.4 Whenever Contractor receives items from another contractor or from Owner for storage, erection or installation, the Contractor receiving such items shall give receipt for items delivered, and thereafter will be held responsible for care, storage and any necessary replacing of item or items received.
- 6.2.5 When certain items of equipment and other work are indicated as "NIC" (not in contract), or to be furnished and installed under other contracts, any requirements set forth in the Contract Documents for preparation of openings, provision of backing, etc., for receipt of such "NIC" work will be furnished upon written request of the Contractor who shall properly form and otherwise prepare his work in a satisfactory manner to receive such "NIC" work.

6.3 OWNER'S RIGHT TO PERFORM DISPUTED WORK

6.3.1 If a dispute arises between the Contractor and Separate Contractors as to their responsibility for cleaning up as required by Section 4.18 or for accomplishing coordination or doing required cutting, filling, excavating or patching as required by Section 4.17, the Owner may carry out such work and charge the cost thereof to the responsible party as the Owner shall determine to be just.

6.4 COORDINATION OF THE WORK

6.4.1 By entering into this Contract, Contractor acknowledges that there may be other contractors on the site whose work will be coordinated with that of his own. Contractor expresses, warrants and guarantees that he will cooperate with other contractors and will do nothing to delay, hinder or interfere with the work of other Separate Contractors, the Owner or Design Consultant. Contractor also expressly agrees that, in the event his work is hindered, delayed, interfered with or otherwise affected by a Separate Contractor, his sole remedy will be a direct action against the Separate Contractor as described in this Article 6. Contractor will have no remedy, and hereby expressly waives any remedy, against the Owner and/or the Design Consultant on account of delay, hindrance, interference or other event caused by a Separate Contractor.

ARTICLE 7

MISCELLANEOUS PROVISIONS

7.1 GOVERNING LAW

7.1.1 This Contract shall be governed by the laws of the State of North Carolina.

7.1.2 Each and every provision of law and clause required by law to be inserted in this Contract shall be deemed to be inserted herein and the Contract shall be read and enforced as though it were included herein. If through mistake or otherwise, any such provision is not inserted or is not correctly or fully inserted, then upon the application of either party, the Contract shall forthwith be physically amended to make such insertion.

7.2 SUCCESSORS AND ASSIGNS

7.2.1 The Owner and the Contractor each binds himself, his partners, successors, assigns and legal representatives to the other party hereto and to the partners, successors, assigns and legal representatives of such other party in respect to all covenants, agreements and obligations contained in the Contract Documents. The Contractor shall not assign the Contract or sublet it as a whole without the written consent of the Owner, nor shall the Contractor assign any moneys due or to become due to him hereunder, without the previous written consent of the Owner and the Contractor's Surety.

7.3 CLAIMS AND DAMAGES

7.3.1 Should the Contractor, Subcontractor or any Sub-subcontractor suffer injury or damage to person or property because of any act or omission of the Owner or Design Consultant, or of any of their employees, agents or others for whose acts either is legally liable, the Claim on behalf of the Contractor its Subcontractors or Sub-subcontractors shall be made by giving Notice to

the Owner, as provided in Article 15 ; otherwise, the Contractor, Subcontractors and Sub-subcontractors shall have waived any and all rights he may have against the Owner or the Design Consultant, or their employees, representatives and agents. The Contractor shall indemnify, defend and hold the Owner harmless from any Claim by a Subcontractor that is waived because it is not filed in strict conformance with this Paragraph or any other provision of the Contract regarding Claims.

7.4 PERFORMANCE BOND AND LABOR AND MATERIAL PAYMENT BOND

7.4.1 The Contractor shall furnish bonds covering the faithful performance of the Contract and the payment of all obligations arising thereunder in a form and with a Surety satisfactory to the Owner.

7.4.2 The Contractor is required to furnish in duplicate a Performance Bond and a Labor and Material Payment Bond, each in the amount of one hundred percent (100%) of the Contract Sum, written by a surety company licensed to do business in North Carolina and with a minimum AM Best “A” rating or comparable rating from another service reasonably acceptable to Owner.

7.5 RIGHTS AND REMEDIES

7.5.1 The duties and obligations of the Contractor imposed by the Contract Documents and the rights and remedies of the Owner available thereunder shall be in addition to and not a limitation of any duties, obligations, rights and remedies otherwise imposed or available by law.

7.5.2 Except as may be specifically agreed in writing, the failure of the Owner or the Design Consultant to insist in any one or more instances upon the strict performance of any one or more of the provisions of the Contract, or to exercise any right herein contained or provided by law, shall not be construed as a waiver or relinquishment of the performance of such provisions or right(s) or of the right to subsequently demand such strict performance or exercise such right(s), and the rights shall continue unchanged and remain in full force and effect.

7.5.3 The Contractor agrees that he can be adequately compensated by money damages for any breach of the Contract which may be committed by the Owner and hereby agrees that no default, act, or omission of the Owner or the Design Consultant, except for failure to make progress payments as required by the Contract Documents, shall constitute a material breach of the Contract entitling the Contractor to cancel or rescind the provisions of the Contract or (unless the Owner shall so consent or direct in writing) to suspend or abandon performance of all or any part of the Work. The Contractor hereby waives any and all rights and remedies to which he might otherwise be or become entitled, save only his right to money damages.

7.6 TESTS AND INSPECTIONS

7.6.1 If the Contract Documents, laws, ordinances, rules, regulations or orders of any public authority having jurisdiction require any portion of the Work to be inspected, tested, or approved, the Contractor shall give the Owner and Design Consultant timely Notice of its readiness so the Design Consultant and the Owner may observe such inspection, testing or approval. Unless otherwise specifically provided in the Contract Documents, the Contractor shall bear all costs of such inspections, tests or approvals, except that Owner shall pay for “special inspections” as defined and required in Section 1704, the North Carolina State Building Code, or successor section. In the event that such “special inspections” reveal a failure of the Work to comply with the Contract Documents or applicable laws, ordinances, regulations or orders of public authorities having jurisdiction, Contractor shall reimburse the Owner for the costs of such

“special inspections”.

- 7.6.1.1 Unless otherwise stipulated in the Contract Documents, the Contractor shall pay for all utilities required for testing of installed equipment of all of his work and work of each Subcontractor. Boiler fuel other than gas shall be provided by Subcontractor furnishing boilers. Labor and supervision required for making such tests shall be provided at no additional cost to the Owner.
- 7.6.2 If the Design Consultant or the Owner determines that any portion of the Work requires additional inspection, testing, or approval which Paragraph 7.6.1 does not include, the Owner will instruct the Contractor to order such additional inspection, testing or approval, and the Contractor shall give Notice as provided in Paragraph 7.6.1. If such additional inspection or testing reveals a failure of any portion of the Work to comply (1) with the requirements of the Contract Documents, or (2) with respect to the performance of the Work, with laws, ordinances, rules, regulations, or orders of any public authority having jurisdiction, the Contractor shall bear all costs thereof, including compensation for the Design Consultant's and Owner's additional construction management expenses made necessary by such failure.
- 7.6.3 With regard to inspections and tests, the costs of which the Owner is responsible for paying, they will be made by a pre-qualified, independent testing agency selected by the Owner. The cost of the initial services of such agency will be paid by the Owner. When the initial tests indicate non-compliance with the Contract Documents, any subsequent testing occasioned by non-compliance shall be performed by the same agency and the cost thereof shall be borne by the Contractor. Representatives of the testing agency shall have access to the Work at all times. The Contractor shall provide facilities for such access in order that the agency may properly perform its functions.
- 7.6.4 The independent testing agency, contracted by the Owner, shall prepare the test reports, logs, and certificates applicable to the specific inspections and tests and promptly deliver the specified number of copies to the designated parties. Certificates of inspection, testing or approval required by public authorities shall be secured by the Contractor and promptly delivered by him to the Owner, in adequate time to avoid delays in the Work or final payment therefore.
- 7.6.5 If the Design Consultant or the Owner is to observe the inspections, tests or approvals required by the Contract Documents, laws, ordinances, rules, regulations, or order of any public authority having jurisdiction or that are required to establish compliance with the Contract Documents, he will do so promptly and, where practicable, at the normal place of testing.
- 7.6.6 The Contractor shall pay for and have sole responsibility for inspections or testing performed exclusively for his own convenience.
- 7.7 UNENFORCEABILITY OF ANY PROVISION
- 7.7.1 If any provision of this Contract is held as a matter of law to be unenforceable or unconscionable, the remainder of the Contract shall be enforceable without such provision.
- 7.8 ATTORNEYS' FEES AND OTHER EXPENSES
- 7.8.1 The Contractor hereby agrees that he will not submit, assert, litigate or otherwise pursue any frivolous or unsubstantiated Claims or Claims he has specifically waived under the terms of the Contract Documents. In the event that the Contractor's or its Subcontractor's or Sub-subcontractor's Claims, or any separate item of a Claim, is without substantial justification, the Contractor shall reimburse the Owner or Design Consultant for all costs and expenses associated

with defending such Claim or separate item, including but not limited to, attorneys' fees, audit costs, accountants' fees, expert witness' fees, additional Design Consultant expenses, additional construction management expenses, or services and any other consultant costs.

- 7.8.2 If the Contractor breaches any obligation under the Contract Documents, the Contractor shall reimburse the Owner and Design Consultant for all costs and expenses incurred by the Owner relating to such breach, including but not limited to attorneys' fees, audit costs, accountants' fees, expert witness' fees, additional Design Consultant expenses, additional construction management expenses, and any other consultant costs.
- 7.8.3 If the Owner or Design Consultant substantially prevails in a Claim brought against the Contractor, or in defending a Claim brought by the Contractor, including but not limited to, Claims for fraud or misrepresentation, overpayment, defective work, delay damages, and recovery of termination expenses, the Contractor shall reimburse the Owner and/or Design Consultant for all costs and expenses incurred by them relating to such Claim, including but not limited to attorneys' fees, audit costs, accountants' fees, expert witness' fees, additional Design Consultant expenses, additional construction management expenses, and any other consultant costs.

ARTICLE 8

TIME

8.1 DEFINITIONS

- 8.1.1 Unless otherwise provided, the Contract Time is the period of time allotted in the Contract Documents for Final Completion of the Work as defined in Paragraph 8.1.4, including authorized adjustments thereto. The Contractor shall achieve Final Completion within the Contract Time.
- 8.1.2 The date of commencement of the Work is the date established in the Notice to Proceed. If there is no Notice to Proceed, it shall be the date of the Owner-Contractor Agreement or such other date as may be established therein. The Contractor shall not commence work or store materials or equipment on site until written Notice to Proceed is issued or until the Contractor otherwise receives the Owner's written consent.
- 8.1.3 The date of Substantial Completion of the Work or designated portion thereof is the date certified by the Design Consultant and the Owner when the Work or a designated portion thereof is sufficiently complete, in accordance with the Contract Documents, so the Owner can fully and legally occupy and utilize the Work or designated portion thereof for the use for which it is intended, with all of the parts and systems operable as required by the Contract Documents, including a preliminary test and balance report for the mechanical system. Only incidental corrective work and any final cleaning beyond that needed for the Owner's full use may remain for Final Completion. The Contractor acknowledges and agrees that the intercom, telephone, data security, building automation system (including functional graphics at the site), MATV, and other educational operational systems are required for the Owner's use of the building for its intended purpose. The Contractor shall provide operation and maintenance manuals to the Owner as required by the Contract Documents prior to Substantial Completion and shall provide the required training on the operation of the equipment and systems within two weeks of Substantial Completion. The Contractor shall achieve Substantial Completion by the date specified in the Supplemental Conditions including authorized adjustments thereto. The Owner's occupancy of incomplete work shall not alter the Contractor's responsibilities pursuant

to this paragraph. Only incidental corrective work and any final cleaning beyond that needed for the Owner's full use may remain for Final Completion. The issuance of a temporary or final certificate of occupancy shall not, in itself, constitute Substantial Completion.

8.1.4 Final Completion of the Work occurs on the date certified by the Design Consultant and the Owner when the Work is totally complete, to include punch list work, in accordance with the Contract Documents and the Owner may fully occupy and utilize the Work for the use for which it is intended. The issuance of a temporary or final certificate of occupancy shall not, in itself, constitute Final Completion.

8.1.5 The term Day as used in the Contract Documents shall mean calendar day unless otherwise specifically designated. All dates shall mean midnight of the indicated day unless otherwise stipulated.

8.1.6 Completion Dates shall mean the dates set forth in the Supplemental Conditions for Substantial Completion and Final Completion.

8.2 PROGRESS AND COMPLETION

8.2.1 All time limits stated in the Contract Documents are of the essence of the Contract with respect to the Contractor's performance.

8.2.2 The Contractor shall begin the Work on the date of commencement as defined in Paragraph 8.1.2. He shall carry the Work forward expeditiously with adequate forces and shall achieve Substantial Completion and Final Completion within the time frames stated in the Contract Documents.

8.2.3 Attention is directed to the fact that the Work is urgently needed by the Owner; for this reason, it shall be agreed that the Contractor and its Subcontractors will achieve Substantial Completion of the Work under the Contract within the time established under Paragraph 8.2.4 of the Supplemental Conditions after award of Contract, or Notice to Proceed, and that he will achieve Final Completion of the Work in all its details for final acceptance within the time established under Paragraph 8.2.4 of the Supplemental Conditions.

8.3 DELAYS AND EXTENSIONS OF TIME

8.3.1 The time during which the Contractor or any of the Subcontractors is delayed in the performance of the Work by the issuance of any required permits, acts of god, excessive inclement weather, fires, floods, epidemics, quarantine restrictions, strikes, riots, civil commotions or freight embargoes, or other conditions beyond the Contractor's or the Subcontractors' control and which the Contractor or the Subcontractors could not reasonably have foreseen and provided against, except for delays caused solely by the Owner, Design Consultant or their consultants, shall be added to the time for completion of the Work stated in the Contract. Neither the Owner nor the Design Consultant shall be obligated or liable to the Contractor or the Subcontractors for indirect or direct damages, costs or expenses of any nature which the Contractor, the Subcontractors, or any other person may incur as a result of any of the delays, interferences, changes in sequence in the Work included in this Section 8.3.1. The Contractor hereby expressly waives any Claims against the Owner and the Design Consultant on account of any indirect or direct damages, lost profits, costs or expenses of any nature which the Contractor, the Subcontractors or any other person may incur as a result of any delays, interferences, changes in sequence or the like, and it is understood and agreed that the Contractor's sole and exclusive

remedy in any such events shall be an extension of the Contract time in accordance with the Contract Documents.

- 8.3.2 In the event Project delays arise from or out of any act or omission of the Owner, Design Consultant or their consultants, the time during which the Project is delayed shall be added to the Contract and the Contractor may be reimbursed for its direct Project damages, excluding general overhead expenses and indirect costs, if the Contractor strictly complies with this Article 8.3. Notwithstanding the previous sentence, if the Contractor or Subcontractor in any way shares in responsibility for the delay, neither the Owner nor the Design Consultant shall be obligated or liable to the Contractor or the Subcontractors for indirect or direct damages, costs or expenses of any nature which the Contractor, the Subcontractors, or any other person may incur as a result of any of the delays, interferences, changes in sequence of the Work, and the Contractor's sole remedy, if any, shall be an extension of the Contract time.
- 8.3.3 In the event Project delays arise solely from or out of any act or omission of the Contractor, Subcontractors or their agents, the Contractor shall not be entitled to extension of the Contract time and shall be subject to the payment of Liquidated Damages as provided in this Contract.
- 8.3.4 The Contract time shall be adjusted only for changes pursuant to section 12.1, suspension of the Work pursuant to paragraph 3.3.2 or paragraph 3.3.3, and excusable delays pursuant to paragraph 8.3.4. In the event the Contractor requests an extension of the Contract time or files a Claim related to any form of delay, it shall furnish such justification and supporting evidence as the Owner may deem necessary for a determination of whether or not the Contractor is entitled to an extension of time under the provisions of the Contract, and shall further conform to all of the requirements of the specifications and the Contract regarding construction schedules and reports. The burden of proof to substantiate a Claim shall rest with the Contractor, including evidence that the cause was beyond its control. The Owner shall base its findings of fact and decision on such justification and supporting evidence, including a finding that the alleged delay impacted the Project's critical path, and shall advise the Contractor in writing thereof. If the Owner finds that the Contractor is entitled to any extension of the Contract time, the Owner's determination of the total number of days of extension shall be based upon the currently approved progress schedule and on all data relevant to the extension. Such data will be incorporated into the schedule in the form of a revision thereto, accomplished in a timely manner. The Contractor acknowledges and agrees that actual delays (due to said changes, suspension of Work or excusable delays) in activities which, according to the schedule, do not affect the Contract time, do not have any effect upon the Contract time and therefore will not be the basis for a change therein. The Contractor acknowledges and agrees that time extensions will be granted only to the extent that excusable delays exceed the available float in the critical path activities in the Contractor's currently approved schedule.
- 8.3.4.1 Extensions in the Contract time by Change Orders are subject to extension-in-time audit by the Owner as follows:
- 8.3.4.1.1 The Contractor agrees that, even though the Owner, Contractor and Design Consultant have previously signed a Change Order containing an extension-in-time resulting from a change in or addition to the Work that said extension in the Contract time may be adjusted by an audit after the fact by the Owner. If such an audit is to be made, the Owner must undertake the audit and make a ruling within thirty (30) days after the completion of the Work under the Change Order.
- 8.3.4.1.2 The Contractor agrees that any extension of the Contract time to which it is entitled arising out of a Change Order undertaken on a force accounting (labor and materials) basis, shall be

determined by an extension-in-time audit by the Owner after the Work of the Change Order is completed. Such rulings shall be made by the Owner within thirty (30) days after a request for same is made by the Contractor or Design Consultant, except said thirty (30) days will not start until the Work under the Change Order is completed.

- 8.3.4.1.3 Should a time extension be granted for Substantial Completion the date for Final Completion shall be appropriately adjusted unless specifically stated otherwise.
- 8.3.4.2 Subject to other provisions of the Contract, the Contractor may be entitled to an extension of the Contract time (but no increase in the Contract sum) for delays arising from unforeseeable causes beyond the control and without the fault or negligence of the Contractor, the Subcontractors or suppliers as follows:
 - 8.3.4.2.1 Labor disputes and strikes (including strikes affecting transportation), that do, in fact, directly delay the progress of the Work on the critical path; however, an extension of Contract time on account of an individual labor strike shall not exceed the number of days of said strike;
 - 8.3.4.2.2 Acts of nature: tornado, fire, hurricane, blizzard, earthquake, or flood that damage Work in place or stored materials or adversely impact the schedule's critical path;
 - 8.3.4.2.3 Excessive inclement weather; however, the Contract time will not be extended due to reasonably anticipated inclement weather or for delays in the aftermath of inclement weather, reasonably anticipated or excessive. The time for performance of this Contract, as stated in the Contract Documents, includes an allowance for calendar days which may not be available for construction out-of-doors; for the purposes of this Contract, the Contractor agrees that the number of calendar days per month based on a five-year average shall be considered reasonably anticipated inclement weather and planned for in the construction schedule and the Contract Documents. Unless the Contractor can substantiate to the satisfaction of the Owner that there was greater than the reasonably anticipated inclement weather considering the total cumulative time from the notice-to-proceed until the date established for Substantial Completion using data from the national weather service station identified in the Supplemental Conditions, or a weather station acceptable to the Owner and that such alleged greater than reasonably anticipated inclement weather actually delayed the Work or portions thereof which had an effect upon the Contract time, the Contractor shall not be entitled to an extension of time.

Also the Contractor agrees that the calculation of the number of excessive inclement weather days shall be the number of days in excess of the five-year average for each month, in which precipitation exceeded one tenth (.10) inch, or in which the highest temperature was 32 degrees F or less as recorded at the approved weather station. Rain days from hurricanes and tropical storms not causing damage in the county in which the project is located shall be deemed inclement weather days.

If the total accumulated number of calendar days lost to excessive inclement weather, from the notice-to-proceed until the date established for Substantial Completion, exceeds the total accumulated number to be reasonably anticipated for the same period based upon the five-year average, time for completion will be extended by the number of calendar days needed to include the excess number of calendar days lost. No extension of time will be made for days due to excessive inclement weather occurring after the date established for Substantial Completion or for work out of doors that is not on the critical path. No change in Contract sum will be authorized because of adjustment of Contract time due to excessive inclement weather; and

- 8.3.4.2.4 Delays in the issuance of the building permit required for construction of the Project, acts of the public enemy, acts of the State, Federal or local government in its sovereign capacity, and acts of another Contractor in the performance of a Contract with the Owner relating to the Project.
- 8.3.5 If the Contractor shall neglect, fail or refuse to complete the Work within the time herein specified, or any proper extension thereof granted by the Owner, then the Contractor does hereby agree, as a part consideration for the awarding of this Contract, to pay the Owner the amount specified in the Contract, not as a penalty but as Liquidated Damages for such breach of Contract as hereinafter set forth, for each and every calendar day that the Contractor shall be in default after the time stipulated in the Contract for completing the Work. The said amount is fixed and agreed upon by and between the Contractor and the Owner because of the impracticability and extreme difficulty of fixing and ascertaining the actual damages the Owner would in such event sustain, and said amount is agreed to be the amount of damages which the Owner would sustain and said amount shall be retained from time to time by the Owner from current periodical estimates.
- 8.3.6 The Contractor and the Subcontractors shall not be entitled to and hereby expressly waive any extension of time resulting from any condition or cause unless said Claim for extensions of time is made in writing to the Owner within ten (10) days of the first instance of delay for all delays, except excessive inclement weather which shall be made in writing to the Owner within forty-five (45) days after the date established for Substantial Completion. Circumstances and activities leading to such Claim shall be indicated or referenced in a daily field inspection report for the day(s) affected. In every such written Claim, the Contractor shall provide the following information:
- 8.3.6.1 Nature of the delay;
- 8.3.6.2 Date (or anticipated date) of commencement of delay;
- 8.3.6.3 Activities on the progress schedule affected by the delay, and/or new activities created by the delay and their relationship with existing activities;
- 8.3.6.4 Identification of person(s) or organization(s) or event(s) responsible for the delay;
- 8.3.6.5 Anticipated extent of the delay; and
- 8.3.6.6 Recommended action to avoid or minimize the delay.
- 8.3.7 If no schedule or agreement is made stating the dates upon which written interpretations as set forth in Section 2.2 shall be furnished, then no Claim for delay shall be allowed on account of failure to furnish such interpretations until twenty (20) days after request is made for them, and not then unless such Claim is reasonable.
- 8.3.8 No Claim by the Contractor for an extension of time for delays will be considered unless made in strict compliance with the requirements of this Article. All Claims not filed in accordance with this paragraph shall be waived by the Contractor.
- 8.4 RESPONSIBILITY FOR COMPLETION
- 8.4.1 The Contractor shall be responsible for completion in accordance with Paragraph 4.12.1.
- 8.4.2 The Owner may require the Contractor to submit a recovery schedule demonstrating his program

and proposed plan to make up the lag in scheduled progress and to ensure completion of the Work within the Contract Time if the Project is behind schedule by four (4) or more days. If the Owner finds the proposed plan not acceptable, he may require the Contractor to submit a new plan. If the actions taken by the Contractor or the second plan proposed are not satisfactory, the Owner may require the Contractor to take any of the actions set forth in Paragraph 4.12.2 without additional cost to the Owner, to make up the lag in scheduled progress.

8.4.3 Failure of the Contractor to substantially comply with the requirements of this Section 8.4 may be considered grounds for a determination by the Owner, pursuant to Section 14.3, that the Contractor is failing to prosecute the Work with sufficient diligence to ensure its completion within the Contract Time.

8.5 LIQUIDATED DAMAGES FOR DELAY

8.5.1 Owner and Contractor agree that the damages incurred by the Owner due to the Contractor's failure to achieve Substantial Completion by the date specified in the Supplemental Conditions for Substantial Completion, including any extensions thereof, shall be in the amounts set forth in the Supplemental Conditions, for each consecutive day beyond the date of Substantial Completion that Contractor achieves Substantial Completion, and that the damages incurred by the Owner due to the Contractor's failure to achieve Final Completion by the date specified in the Supplemental Conditions for Final Completion, including any extensions thereof, shall be in the amount set forth in the Supplemental Conditions for each consecutive day beyond the date of Final Completion that Contractor achieves Final Completion. The Liquidated Damages are a reasonable estimate by Contractor and Owner of the damages to be suffered by Owner and are not to be construed as a penalty, it being recognized by the Owner and the Contractor that the injury to the Owner which could result from a failure of the Contractor to complete on schedule is uncertain and cannot be computed exactly or that it would be unreasonably expensive for Owner to calculate its damages exactly.

8.5.2 The amount specified for Substantial Completion is the minimum measure of damages the Owner will sustain due to delay in the completion of the Work, which shall include, but not be limited to the loss of use of the facilities, the relocation of students and services, the cost of the Owner's time and resources, damage to the Owner's reputation, and storage of furniture and other materials. The amount specified for Final Completion is a reasonable and proper measure of the damages the Owner will sustain due to the delay in the completion of remedial work. This amount includes the disruption to the school and the learning environment, the cost of the Owners time and resources, damage to the Owner's reputation, and the inability to fully use the facilities. The inability of the Owner to quantify actual damages shall not prevent the recovery of Liquidated Damages.

8.5.3 Notwithstanding any other provisions of these General Conditions, if there is concurrent delay in the completion of the Work, the Contractor shall be liable for Liquidated Damages as specified in the General Conditions and Supplemental Conditions during such period of concurrent delay. For the purpose of this Paragraph, concurrent delay means (a) a delay event caused in part by the Owner or its agent and in part by the Contractor or its agents, Subcontractors or Sub-subcontractors, or (b) one or more delay event caused solely by the Owner, its agents, or the Design Consultant, and one or more delay event caused in part by the Contractor, its agents, Subcontractors or Sub-subcontractors, each of which would have resulted in a delay without the other and which delays run concurrently, or at the same time. In the event that the foregoing provision making the Contractor liable for Liquidated Damages during a period of concurrent delay is found to be unenforceable, then the parties agree that in the event of a concurrent delay, the extent of the delay will be apportioned between the Owner and the

Contractor, and the Contractor will be responsible for Liquidated Damages as set forth in the General Conditions and Supplemental Conditions for those portions of the delay which are apportioned to the Contractor, its agent, Subcontractors, Sub-subcontractors, or Material Suppliers.

- 8.5.4 The provisions for Liquidated Damages do not bar or limit Owner's other rights and remedies against Contractor, for damages other than for failure to achieve the Substantial Completion date or the Final Completion date as required. The amount of Liquidated Damages set forth in Section 8.5 shall not include additional legal or design professional costs that may result from the Contractor's default. If such legal or design professional costs are incurred by the Owner, the Contractor shall be liable to the Owner for those costs in addition to the Liquidated Damages amount set forth in Section 8.5.
- 8.5.5 The Liquidated Damages assessed for failure to meet Substantial Completion by the specified date and the Liquidated Damages assessed for failure to meet Final Completion by the specified date shall be assessed cumulatively.

ARTICLE 9

PAYMENTS AND COMPLETION

9.1 CONTRACT SUM

- 9.1.1 The Contract Sum is stated in the Owner-Contractor Agreement and, including authorized adjustments thereto, is the total amount payable by the Owner to the Contractor for the performance of the Work under the Contract Documents.

9.2 SCHEDULE OF VALUES

- 9.2.1 Before the first Application for Payment, the Contractor shall submit to the Owner a schedule of values allocated to the various portions of the Work and supported by such data to substantiate its accuracy as the Owner may require. This schedule, unless objected to by the Owner, shall be used as a basis for the Contractor's Applications for Payment and only for this purpose. If approved by the Owner, the Contractor may include in his schedule of values a line item for mobilization which shall include a reasonable amount of mobilization for the Contractor and his Subcontractors. The Contractor shall not front-end load his schedule of values.

9.3 APPLICATIONS FOR PAYMENT

- 9.3.1 Prior to the date for each progress payment established in the Owner-Contractor Agreement, the Contractor shall submit to the Design Consultant an itemized Application for Payment, notarized if required, supported by such data substantiating the Contractor's right to payment as the Design Consultant and the Owner may require, including but not limited to the Contractor's certification that all work for which payment is requested has been completed in full in accordance with the Contract Documents, and reflecting retainage, if any, as provided elsewhere in the Contract Documents. If requested by the Owner, the Contractor shall also certify that he has paid all due and payable amounts for which previous Applications for Payment were issued and payments received from the Owner, by providing waivers of liens for said payments.

- 9.3.1.1 The Contractor shall submit with the Application for Payment a list of those minority and Historically Underutilized Businesses (HUBs) Subcontractors whose work is included in the application and the amount due each. In addition, the minority and Historically Underutilized

Business (HUBs) must itself perform satisfactory work or services or provide supplies under the Contract and not act as a mere conduit.

- 9.3.2 The Owner will withhold retainage from Contractor on all Applications for Payment to the maximum extent and in the maximum amount allowed by law (currently codified at N.C.G.S. 143-134.1) and in accordance with that statute or applicable successor statute. In the event that N.C.G.S 143-134.1 or applicable successor statute are not in effect or do not apply at the time the Contract is executed, Owner will retain five percent (5%) of the amount of each Application for Payment from the Contractor as retainage, until Contractor achieves Final Completion, whether or not the Owner has occupied any or all of the Project before such time. However, if the Owner, at any time after fifty percent (50%) of the Work has been completed, finds that satisfactory progress is being made, he may authorize payment to the Contractor in full of each Progress Payment for work performed beyond the fifty percent (50%) stage of completion. If a reduction in retainage has been made, the Owner may increase the retainage back to original percentage at any time if the Owner concludes that the Contractor is not progressing with the Work in a timely or satisfactory manner.
- 9.3.3 Payments may be made by the Owner, at its sole discretion, on account of materials or equipment not incorporated in the work but delivered and suitably stored at the site or in a bonded warehouse by the Contractor. Payments for materials or equipment stored shall only be considered upon submission by the Contractor of satisfactory evidence (for example, releases or paid invoices from the seller) that the Contractor has acquired title to such material, that it will be utilized on the work under this Contract and that it is satisfactorily stored, protected, and insured or that other procedures satisfactory to the Owner that will protect the Owner's interests have been taken. In the event the materials are stored in a bonded warehouse that is not located in the county of the project, the Contractor shall reimburse the travel cost and hourly billing expenses incurred by the Design Consultant for travel to view and assess whether the materials meet the requirements of the Contract Documents. Materials once paid for by the Owner become the property of the Owner and may not be removed from the work site or bonded warehouse, other than to be delivered from the warehouse to the site, without the Owner's written permission. Responsibility for such stored materials and equipment shall remain with the Contractor regardless of ownership.
- 9.3.3.1 Owner will not make payment to the Contractor on account of materials or equipment not incorporated in the Work but delivered and stored at the site if the Contractor, in his schedule of values, does not include line items for such delivered and stored materials or equipment.
- 9.3.3.2 It is specifically understood and agreed that an inspection and approval of the materials by the Owner, the Design Consultant or any agency retained by any of them shall not in any way subject the Owner to pay for the said materials or any portion thereof, even though incorporated in the Work, if said materials shall in fact turn out to be unfit to be used in the Work, nor shall such inspection be considered as any waiver of objection to the Work on account of the unsoundness or imperfection of the material used.
- 9.3.4 The Contractor warrants that title to all work, materials and equipment covered by an Application for Payment will pass to the Owner either by incorporation in the construction or upon the receipt of payment by the Contractor, whichever occurs first, free and clear of all liens, claims, security interests or encumbrances, hereinafter referred to in this Article 9 as "liens"; and that no work, materials or equipment covered by an Application for Payment will have been acquired by the Contractor, or by any other person performing work at the site or furnishing materials and equipment for the Project, subject to an agreement under which an interest therein or an encumbrance thereon is retained by the seller or otherwise imposed by the Contractor or

such other person.

9.3.5 The Contractor shall submit with the Application for Payment a notarized Contractor's Sales Tax Report of N.C. State and County sales taxes paid during the payment period with respect to building materials, supplies, fixtures, and equipment that have become a part of, or annexed to, a building or structure erected, altered or repaired for the Owner. The Sales Tax Report shall include the vendor from whom the property was purchased, the dates and number of invoices covering the purchase, the total amount of the invoices of each vendor, the North Carolina State and County sales and use tax paid thereof, and the cost of the property withdrawn from the warehouse stock and North Carolina sales or use taxes paid thereof. Items that should not be included are: scaffolding, forms for concrete, fuel for operation of machinery and equipment, tools, equipment, equipment repair parts and equipment rentals.

9.3.6 Unless an interest rate is required by law, Owner shall not pay any interest on an amount owed to Contractor. No interest shall accrue on amounts Owner is authorized by law or by the Contract to withhold or backcharge to Contractor.

9.4 CERTIFICATION OF PAYMENT

9.4.1 The Design Consultant will, after receipt of the Contractor's Application for Payment either issue a Certification of Payment to the Owner, with a copy to the Contractor, for such amount as the Design Consultant determines is properly due, or notify the Contractor in writing of their reasons for withholding a Certification as provided in Paragraph 9.6.1.

9.4.2 The submission and approval of the progress schedule and monthly updates thereof as required by the Contract Documents shall be an integral part and basic element of the application upon which progress payment shall be made. The Contractor shall be entitled to progress payments only as determined from the currently approved and updated schedule.

9.4.3 The signing of a Certification of Payment will constitute a representation by the Design Consultant to the Owner, based on their observations at the site pursuant to their agreements with the Owner, and the data comprising the Application for Payment, that the Work has progressed to the point indicated; that, to the best of their knowledge, information and belief, the quality of the Work is in accordance with the Contract Documents (subject to an evaluation of the Work for conformance with the Contract Documents upon Substantial Completion, to the results of any subsequent tests required by or performed under the Contract Documents, to minor deviations from the Contract Documents correctable prior to completion, and to any specific qualifications stated in their Certification); and that the Contractor is entitled to payment in the amount certified. However, by signing a Certification of Payment, the Design Consultant shall not thereby be deemed to represent that it has made exhaustive or continuous on-site inspections to check the quality or quantity of the Work or that it has reviewed the construction means, methods, techniques, sequences, or procedures, or that it has made any examination to ascertain how or for what purpose the Contractor has used the moneys previously paid on account of the Contract Sum.

9.5 PROGRESS PAYMENTS

9.5.1 After a Certification of Payment has been issued, the Owner shall make payment in the manner and within the time provided in the Contract Documents, unless Contractor is in breach of the Contract or otherwise owes the Owner, in which case Owner may withhold an appropriate amount.

- 9.5.2 The Contractor shall promptly pay each Subcontractor (including suppliers, laborers, and material-men) performing labor or furnishing material or equipment for the Work, upon receipt of payment from the Owner, out of the amount paid to the Contractor on account of such Subcontractor's work, the amount to which said Subcontractor is entitled, reflecting the percentage actually retained, if any, from payments to the Contractor on account of such Subcontractor's work. The Contractor shall, by an appropriate agreement with each Subcontractor, also require each Subcontractor to make payments to his Sub-subcontractors in similar manner. The Owner may at any time require proof of payment to a Subcontractor or Sub-subcontractor for work paid by the Owner. Notwithstanding any other provision of the General Conditions, no Contractor, Subcontractor, Sub-subcontractor or Material Supplier shall have any Claim against the Owner, by virtue of the Contract, under any theory, including breach of contract, or third party beneficiary. The Owner shall not be in privity of any contract with any Subcontractor, Sub-subcontractor or Material Supplier pertaining to the Work, the Project and these General Conditions. Also, neither the Contractor, or any Subcontractor or Sub-subcontractor shall have any right to assert a lien on Owner's real property or on any funds held by Owner.
- 9.5.3 The Owner may, on request and at his discretion, furnish to any Subcontractor, if practicable, information regarding the percentages of completion or the amounts applied for by the Contractor and the action taken thereon by the Design Consultant on account of work done by such Subcontractor.
- 9.5.4 Neither the Owner nor the Design Consultant shall have any obligation to pay or to see to the payment of any moneys to any Subcontractor except as may otherwise be required by law.
- 9.5.5 No Certification for a progress payment, nor any progress payment or final payment, nor any partial or entire use or occupancy of the Project by the Owner, shall constitute an acceptance of any Work not in accordance with the Contract Documents.
- 9.5.6 The Contractor agrees to keep the Work and the site of the Project free and clear of all liens related to labor and materials furnished in connection with the Work. Furthermore, pursuant to and in compliance with requirements of Paragraph 9.3.4, the Contractor waives any right he may have to file any type of lien in connection with the Work. Notwithstanding anything to the contrary contained in the Contract Documents, if any such lien is filed or there is evidence to believe that any lien may be filed at any time during the progress of the Work or within the duration of this Contract, the Owner may refuse to make any payment otherwise due the Contractor or may withhold from any payment due the Contractor a sum sufficient in the opinion of the Owner to pay all obligations and expenses necessary to satisfy such lien or the underlying claim represented by such lien. The Owner may withhold such payment unless or until the Contractor, within ten (10) days after demand thereof by the Owner, shall furnish satisfactory evidence that the indebtedness and any lien in respect thereof has been satisfied, discharged and released of record, or that the Contractor has legally caused such lien to be released of record pending the resolution of any dispute between the Contractor and the person or persons filing such lien. If the Contractor shall fail to furnish such satisfactory evidence within ten (10) days of the demand thereof, the Owner may discharge such indebtedness and deduct the amount thereof, together with any and all losses, costs, damages and attorney's fees suffered or incurred by the Owner from any sum payable to the Contractor under the Contract Documents, including but not limited to final payment and retained percentage. This Paragraph 9.5.6 shall be specifically included in all Subcontracts and purchase orders entered into by the Contractor. Notwithstanding any other provision of the Contract, nothing in the Contract shall affect the rights of Subcontractors, Sub-subcontractors, Material Suppliers and Vendors from enforcing any lien rights they have against parties other than the Owner.

9.6 PAYMENTS WITHHELD

9.6.1 The Design Consultant may decline to certify payment and may withhold their Certification of Payment in whole or in part, to the extent necessary to reasonably protect the Owner, if in the Design Consultant's opinion it is unable to make representations to the Owner as provided in Paragraph 9.4.3. If the Design Consultant is unable to make representations to the Owner as provided in Paragraph 9.4.3 and to certify payment in the amount of the Application for Payment, it will notify the Contractor as provided in Paragraph 9.4.1. If the Contractor and the Design Consultant cannot agree on a revised amount, the Design Consultant will promptly issue a Certification of Payment for the amount for which it is able to make such representations to the Owner. The Design Consultant may also decline to certify payment because of subsequently discovered evidence or subsequent observations that may nullify the whole or any part of any Certification of Payment previously issued to such extent as may be necessary in its opinion to protect the Owner from loss, because of:

- .1 Defective Work not remedied,
- .2 Third party claims filed, whether in court, in arbitration or otherwise, or reasonable evidence indicating probable filing of such claims,
- .3 Failure of the Contractor to make payments properly to Subcontractors or for labor, materials or equipment,
- .4 Reasonable evidence that the Work cannot be completed for the unpaid balance of the Contract Sum,
- .5 Damage to the Owner or another contractor,
- .6 Reasonable evidence that Contractor will not achieve Substantial Completion and/or Final Completion by the dates specified in the Supplemental Conditions.
- .7 Failure or refusal of the Contractor to carry out the Work in accordance with or to otherwise substantially or materially comply with the Contract Documents,
- .8 Liens filed or reasonable evidence that a lien may be filed for any portion of the Work,
- .9 Failure or refusal of the Contractor to properly schedule and coordinate the Work, to provide progress schedules, reports and updates, or to provide and adhere to a recovery schedule as required by the Contract Documents,
- .10 Failure or refusal of the Contractor to fully comply with the provisions of Section 6.2 requiring the Contractor to direct certain Claims to Separate Contractors and to defend and indemnify the Owner and/or the Design Consultant in the event Separate Contractors file certain Claims,
- .11 Failure or refusal of the Contractor to submit the required information on minority and Historically Underutilized Businesses (HUBs),
- .12 Failure or refusal of the Contractor to submit a notarized North Carolina State and County

Sales Tax Report,

.13 Any other breach of the Contract by Contractor which has or is likely to cause monetary damages or loss to Owner, or

.14 Any other reason authorized by the Contract Documents or by law.

9.6.2 When the above grounds in Paragraph 9.6.1 are removed to the Design Consultant's and Owner's satisfaction, payment shall be made for amounts withheld because of them.

9.7 FAILURE OF PAYMENT

9.7.1 If the Owner does not make payment to the Contractor within the forty-five (45) calendar days after receipt of the Contractor's approved Application for Payment from the Design Consultant through no fault of the Contractor, and the Owner otherwise not being entitled under the Contract Documents or applicable law to withhold payment, then the Contractor may, upon seven (7) additional days' Notice to the Owner, stop the Work until payment of the amount owed according to the Contract Documents has been received. In such event, the Contract Sum shall be increased by the amount of the Contractor's reasonable costs of shut-down, delay and start-up, which shall be effected by appropriate Change Order as provided herein.

9.8 SUBSTANTIAL COMPLETION

9.8.1 When the Contractor considers that the Work, or a designated portion thereof which is acceptable to the Owner, is substantially complete as defined in Paragraph 8.1.3, the Contractor shall prepare for submission to the Owner a list of items which in his opinion are to be completed or corrected and shall request in writing that the Design Consultant and the Owner perform a Substantial Completion inspection. The Design Consultant and the Owner shall review the Contractor's list and shall compile a punch list of items to be corrected and completed. The failure to include any items on such list does not alter the responsibility of the Contractor to complete the Work in accordance with the Contract Documents. When the Design Consultant and the Owner on the basis of an inspection jointly determine that the Work or designated portion thereof is substantially complete, they will then prepare a Certificate of Substantial Completion which shall establish the date of Substantial Completion, shall state the responsibilities of the Owner and the Contractor for security, maintenance, heat, utilities, damage to the Work, and insurance, and shall fix the time within which the Contractor shall complete the items listed therein. Warranties required by the Contract Documents shall commence on the date of Substantial Completion of the Work or designated portion thereof unless otherwise provided in the Certificate of Substantial Completion. The Certificate of Substantial Completion shall be submitted to the Owner and the Contractor for their written acceptance of the responsibilities assigned to them in such Certificate.

9.8.2 Upon Substantial Completion of the Work or designated portion thereof and upon application by the Contractor and certification by the Design Consultant, the Owner shall make payment, except retainage held pursuant to Paragraph 9.3.2, for such work or portion thereof, as provided in the Contract Documents unless Contractor is in breach of the Contract in which case Owner may withhold an appropriate amount.

9.8.3 The acceptance of Substantial Completion payment shall constitute a waiver of all Claims by the Contractor and its Subcontractors and Sub-subcontractors except those previously made in writing and identified by the Contractor as unsettled at the time the Contractor submits the Application for Payment for Substantial Completion, and except for the retainage sums due at

Final Completion. The Contractor shall indemnify and hold the Owner harmless against any Claims by its Subcontractors and Sub-subcontractors that are waived because they were not made in writing and identified by the Contractor as unsettled when the Contractor submitted the Application for Payment for Substantial Completion.

- 9.8.4 The Owner shall have the option to correct or conclude any and all punch list items not completed by the Contractor to the satisfaction of the Design Consultant and the Owner within thirty (30) days from the actual date of Substantial Completion by utilizing its own forces or by hiring others. The cost of such correction of remaining punch list items by the Owner or others shall be deducted from the final payment to the Contractor. If Contractor does not complete certain punch list items within this time period, specified in Paragraph 9.8.4, all warranties and guarantees for such incomplete punch list items shall become effective upon issuance of final payment for the Project. Paragraph 9.8.4 does not limit the Liquidated Damages provisions related to failure to reach Final Completion by the date stipulated in the Contract Documents.
- 9.8.5 The issuance of the Certificate of Substantial Completion does not indicate final acceptance of the Project by the Owner, and the Contractor is not relieved of any responsibility for the Project except as specifically stated in the Certificate of Substantial Completion.
- 9.8.6 Should the Design Consultant and the Owner determine that the Work or a designated portion thereof is not substantially complete, they shall inform the Contractor in writing stating why the Project or designated portion is not substantially complete. The Contractor shall expeditiously complete the Work and shall re-request in writing that the Design Consultant and the Owner perform a Substantial Completion inspection. Costs, if any, associated with such inspection shall be assessed to the Contractor.
- 9.8.7 Certificate of Substantial Completion will not be issued until the following is completed by Contractor:
- .1 Submit Contractor's list of work not yet complete with proposed time for completion signed by Contractor's project superintendent;
 - .2 Submit Certificate of Occupancy;
 - .3 Submit record drawings, maintenance manuals, final project photos, property surveys;
 - .4 Deliver tools, spare parts, extra stock and similar items;
 - .5 Submit warranties, bonds, maintenance agreements and final certifications;
 - .6 Complete start-up testing of all systems and instruction of the Owner's personnel;
 - .7 Coordinate and complete final changeover of permanent locks and transmit keys to Owner;
 - .8 Discontinue and remove temporary facilities from the site;
 - .9 Complete final cleaning;
 - .10 Advise the Owner of pending insurance changeover requirements;
 - .11 Coordinate and complete changeover of security, telephone, cable and other services; and

- .12 Submit pay application showing 100% complete for work claimed to be substantially complete.
- 9.8.8 The Contractor acknowledges that the Design Consultant and its consultants are only required to conduct up to two (2) comprehensive substantial completion inspections as part of its basic services. If more than two (2) substantial completion inspections are required through no fault of the Design Consultant, the cost of the additional inspections shall be paid by the Contractor.
- 9.9 FINAL COMPLETION AND FINAL PAYMENT
- 9.9.1 Upon receipt of the documentation required by Section 9.8, and of written Notice that the Work is ready for final inspection and acceptance and upon receipt of a final Application for Payment, the Design Consultant and the Owner will promptly make such inspection and, when they find the Work acceptable under the Contract Documents and the Contract fully performed, the Design Consultant shall issue a final Certification of Payment stating that to the best of their knowledge, information and belief, and on the basis of their observations and inspections, the Work has been completed in accordance with the terms and conditions of the Contract Documents. The final Certification of Payment will constitute that the conditions precedent to the Contractor's being entitled to final payment as set forth in Section 9.8 have been fulfilled. Payment shall be made to the Contractor in the amount certified by the Design Consultant within forty five (45) calendar days after receipt by the Owner of the final Certification of Payment except for any Work for which the Owner is entitled a credit under the Contract Documents.
- 9.9.1.1 The Contractor acknowledges that the Design Consultant and its consultants are only required to conduct up to two (2) comprehensive final completion inspections as part of its basic services. If more than two (2) final completion inspections are required through no fault of the Design Consultant, the cost of the additional inspections shall be paid by the Contractor.
- 9.9.2 Neither the final payment nor the remaining retained percentage shall become due until the Work is free and clear of any and all liens and the Contractor submits to the Owner:
- .1 An affidavit that all payrolls, bills for materials and equipment, and other indebtedness connected with the Work for which the Owner or his property might in any way be responsible, have been paid or otherwise satisfied;
 - .2 Consent of Surety to final payment;
 - .3 If required by the Owner, other data establishing payment or satisfaction of all such obligations, such as receipts, releases and waivers of liens arising out of the Contract, to the extent and in such form as may be designated by the Owner; and
 - .4 A written certification that:
 - .1 The Contractor has reviewed the requirements of the Contract Documents,
 - .2 The Work has been inspected by the Contractor for compliance with all requirements of the Contract Documents,
 - .3 Pursuant to this inspection, the Contractor certifies and represents that the Work complies in all respects with the requirements of the Contract Documents,

- .4 The Contractor further certifies and represents that all equipment and systems have been installed in accordance with the Contract Documents and have been tested in accordance with the Specification requirements and are operational, and
- .5 The Contractor hereby certifies and represents that the Work is complete in all respects and ready for final inspection.

9.9.3 If any Subcontractor refuses to furnish a release or waiver required by the Owner, the Contractor may furnish a bond satisfactory to the Owner to indemnify him against any loss. If any such lien or claim remains unsatisfied after all payments are made, the Contractor shall refund to the Owner all moneys that the latter may be compelled to pay in discharging such lien or claims, including all costs and reasonable attorney's fees. The Owner may withhold from the final payment any sum that the Owner has reason to believe may be needed to satisfy any lien, claim or threat of lien arising from the Work. The Owner may deduct from the final payment an amount equal to any costs, expenses and attorney's fees incurred by the Owner in removing or discharging any liens or claim arising from the Work.

9.9.4 If, after Substantial Completion of the Work, Final Completion thereof is materially delayed through no fault of the Contractor or by the issuance of Change Orders affecting Final Completion, and the Owner so confirms, the Owner shall, upon application by the Contractor and certification by the Design Consultant, and without terminating the Contract, make payment of the balance due for that portion of the Work fully completed and accepted. If the remaining balance for the portion of the Work not fully completed or corrected is less than the retainage stipulated in the Contract Documents, and if bonds have been furnished as provided in Section 7.4, the written consent of the Surety to the payment of the balance due for that portion of the Work fully completed and accepted shall be submitted by the Contractor to the Design Consultant prior to certification of such payment. Such payment shall be made under the terms and conditions governing final payment, except that it shall not constitute a waiver of Claims.

9.9.5 The making of final payment shall constitute a waiver of all Claims by the Owner against the Contractor except those arising from:

- .1 Unsettled liens, and claims against the Owner or the Design Consultant, or their employees, agents, or representatives;
- .2 Faulty, defective or non-conforming Work;
- .3 Failure of the Work to comply with the requirements of the Contract Documents;
- .4 Terms of any warranties contained in or required by the Contract Documents;
- .5 Damages incurred by the Owner resulting from lawsuits brought against the Owner, the Design Consultant, or their agents, employees or representatives because of failures or actions on the part of the Contractor, his Subcontractors, Sub-subcontractors, or any of their employees, agents or representatives;
- .6 Fraud or bad faith committed by the Contractor or any Subcontractor or supplier during performance of the Work but discovered by Owner after final payment; or
- .7 Claims about which Owner did not have actual knowledge or which increase in scope or amount at the time of final payment.

- 9.9.6 The acceptance of final payment shall constitute a waiver of all Claims by the Contractor except those previously made in writing and identified by the Contractor as unsettled at the time of the final Application for Payment.
- 9.9.6.1 Notwithstanding any other provision of the Contract, Owner may withhold from Contractor payment otherwise due, as a result of any losses, expenses costs or damages suffered or anticipated to be suffered by Owner as a result of Contractor's breach of any provision of the Contract, including but not limited to Liquidated Damages or backcharges against Contractor.
- 9.10 **OWNER'S RIGHT TO OCCUPY INCOMPLETE WORK**
- 9.10.1 Should the Project, or any portion thereof, be incomplete for Substantial or Final Completion at the scheduled date or dates, the Owner shall have the right to occupy any portion of the Project. In such an event, the Contractor shall not be entitled to any extra compensation on account of said occupancy by the Owner or by the Owner's use of the Project, nor shall the Contractor interfere in any way with said use of the Project. Further, in such an event, the Contractor shall not be entitled to any extra compensation on account of the Owner's occupancy and use of the Project, nor shall the Contractor be relieved of any responsibilities of the Contract including the required times of completion. Such occupancy by the Owner shall not, in itself, constitute Substantial or Final Completion.
- 9.10.2 If the Owner exercises his rights under the foregoing and occupies the full Project, then there shall be no Liquidated Damages on account of failure on the Contractor's part to reach Substantial Completion from that date forward. This provision does not affect, however, any Liquidated Damages that would be assessed for any period of time between the contractual date of Substantial Completion and the date of any such occupancy. Further, this provision would have no effect on Liquidated Damages assessed on account of late Final Completion.

ARTICLE 10

PROTECTION OF PERSONS AND PROPERTY

- 10.1 **SAFETY PRECAUTIONS AND PROGRAMS**
- 10.1.1 The Owner, the Design Consultant, or their agents, employees or representatives are not responsible for the means, methods, techniques, sequences or procedures utilized by the Contractor, or for safety precautions and programs in connection with the Work. The Contractor shall be solely responsible for initiating, maintaining and supervising all safety precautions and programs in connection with the Work. This requirement applies continuously throughout the Contract performance, until final payment is made and all punch list and warranty work is performed properly, and is not limited to regular working hours.
- 10.2 **SAFETY OF PERSONS AND PROPERTY**
- 10.2.1 The Contractor shall take all reasonable precautions for the safety of, and shall provide all reasonable protection to prevent damage, injury or loss to:
- .1 All employees on the Work and all other persons who may be affected thereby;
 - .2 All the Work and all materials and equipment to be incorporated therein, whether in storage on or off the site, under the care, custody or control of the Contractor or any of his Subcontractors or Sub-subcontractors, machinery, equipment and all hazards shall be

guarded or eliminated in accordance with all applicable safety regulations; and

- .3 Other property at the site or adjacent thereto, including trees, shrubs, lawns, walks, pavements, roadways, structures and overhead or underground utilities not designated for removal, relocation or replacement in the course of construction.
- 10.2.2 The Contractor shall give all notices and comply with all applicable laws, ordinances, permits, rules, regulations and lawful orders of any public authority bearing on the safety or persons or property or their protection from damage, injury or loss.
 - 10.2.2.1 The Contractor shall at all times safely guard the Owner's property from injury or losses in connection with the Contract. He shall at all times safely guard and protect his own work and adjacent property as provided by law and the Contract Documents, from damage. All passageways, guard fences, lights and other facilities required for protection by applicable safety regulations must be provided and maintained.
 - 10.2.3 The Contractor shall erect and maintain, as required by existing conditions and progress of the Work, all reasonable safeguards for safety and protection, including posting danger signs and other warnings against hazards, promulgating safety regulations and notifying owners and users of adjacent utilities.
 - 10.2.4 When the use or storage of explosives or other hazardous materials or equipment is necessary for the execution of the Work, the Contractor shall exercise the utmost care and shall carry on such activities under the supervision of properly qualified personnel.
 - 10.2.5 The Contractor shall promptly remedy at his own cost and expense all damage or loss to any property referred to in Subparagraphs 10.2.1.2 and 10.2.1.3 caused by the Contractor, any Subcontractor, any Sub-subcontractor, or anyone directly or indirectly employed by any of them, or by anyone for whose acts any of them may be liable and for which the Contractor is responsible under Subparagraphs 10.2.1.2 and 10.2.1.3, except damage or loss attributable solely to the acts or omissions of the Owner or Design Consultant or anyone directly or indirectly employed by either of them, or by anyone for whose acts either of them may be liable, and not attributable to the fault or negligence of the Contractor. The foregoing obligations of the Contractor are in addition to his obligations under Section 4.21. The Contractor shall perform such restoration by underpinning, repairing, rebuilding, replanting, or otherwise restoring as may be required or directed by the Owner, or shall make good such damage in a satisfactory and acceptable manner. In case of failure on the part of the Contractor to promptly restore such property or make good such damage, the Owner may, upon two (2) calendar days Notice, proceed to repair, rebuild or otherwise restore such property as may be necessary and the cost thereof, or a sum sufficient in the judgment of the Owner to reimburse the owners of property so damaged, will be deducted from any monies due or to become due the Contractor under the Contract.
 - 10.2.6 The Contractor is responsible for the proper packing, shipping, handling and storage (including but not limited to shipment or storage at the proper temperature and humidity) of materials to be incorporated in the Work, so as to insure the preservation of the quality and fitness of the material for proper installation and incorporation in the Work, as required by the Contract Documents. For example, but not by way of limitation, Contractor shall, when necessary, place material on wooden platforms or other hard and clean surfaces and not on the ground and/or place such material under cover in any appropriate shelter or facility. Stored materials or equipment shall be located so as to facilitate proper inspection. Material and equipment which is delivered crated shall remain crated until ready for installation. Lawns, grass plots or other

private property shall not be used for storage purposes without the written permission of the Owner or lessee unless otherwise within the terms of the easements obtained by the Owner.

- 10.2.6.1 It shall be the responsibility of the Contractor in his preparation of phasing schedule of work operations after consulting with the other Prime Contractors to designate areas in which each Prime Contractor may store materials. Areas designed shall meet with the approval of the Design Consultant.
- 10.2.7 The Contractor shall give notice in writing at least forty eight (48) hours before breaking ground, to all persons, public utility companies, owners of property having structures or improvements in proximity to site of the Work, superintendents, inspectors, or those otherwise in charge of property, streets, water pipes, gas pipes, sewer pipes, telephone cables, electric cables, railroads or otherwise, who may be affected by the Contractor's operation, in order that they may remove any obstruction for which they are responsible and have representative on site to see that their property is properly protected. Such notice does not relieve the Contractor of responsibility for all damages, claims, or defense or indemnification of all actions against Owner resulting from performance of such work in connection with or arising out of Contract.
- 10.2.8 The Contractor shall investigate, locate, mark and protect all utilities encountered or to be encountered while performing the Work, whether indicated on the Drawings or not. The Contractor shall maintain utilities in service until moved or abandoned. The Contractor shall exercise due care when excavating around utilities and shall restore any damaged utilities to the same condition or better as existed prior to starting the Work, at no cost to the Owner. The Contractor shall maintain operating utilities or other services, even if they are shown to be abandoned on the Contract Drawings, in service until new facilities are provided, tested and ready for use.
- 10.2.9 The Contractor shall return all improvements on or about the site and adjacent property which are not shown to be altered, removed or otherwise changed to conditions which existed prior to starting the Work. The Contractor shall video record all areas or otherwise document the conditions existing at the site and in and around existing buildings prior to starting the Work. Submit documentation to the Design Consultant prior to beginning the Work.
- 10.2.10 The Contractor shall protect the Work, including but not limited to, the site, stored materials and equipment, excavations, and excavated or stockpiled soil or other material, intended for use in the Work, and shall take all necessary precautions to prevent or minimize damage to same or detrimental effect upon his performance or that of his Subcontractors, caused by or due to rain, snow, ice, run-off, floods, temperature, wind, dust, sand and flying debris; for example, but not by way of limitation, Contractor shall, when necessary, utilize temporary dikes, channels or pumping to carry-off divert or drain water, and shall as necessary tie-down or otherwise secure the Work and employ appropriate covers and screens.
- 10.2.11 The Contractor shall designate a responsible member of his organization at the site whose duty shall be the prevention of accidents and the protection of material, equipment and property. This person shall be the Contractor's superintendent unless otherwise designated by the Contractor in writing to the Owner.
- 10.2.12 The Contractor shall not load or permit any part of the Work to be loaded so as to endanger its safety.
- 10.2.13 Notification to the Contractor by the Owner or the Design Consultant of a safety violation will in no way relieve the Contractor of sole and complete responsibility for the correctness of said

violation or of sole liability for the consequences of said violation.

10.3 EMERGENCIES

- 10.3.1 In any emergency affecting the safety of persons or property, the Contractor shall act, at his discretion, to prevent threatened damage, injury or loss. The Contractor shall notify the Owner of the situation and all actions taken immediately thereafter. If, in the opinion of the Contractor, immediate action is not required, the Contractor shall notify the Owner of the emergency situation and proceed in accordance with the Owner's instructions. Provided, however, if any loss, damage, injury or death occurs that could have been prevented by the Contractor's prompt and immediate action, the Contractor shall be fully liable for all costs, damages, claims, actions, suits, attorney's fees and all other expenses arising therefrom or relating thereto.

ARTICLE 11

INSURANCE

11.1 CONTRACTOR'S LIABILITY INSURANCE

- 11.1.1 The Contractor shall purchase and maintain in companies properly licensed by the Insurance Department of the State of North Carolina and acceptable to the Owner such insurance as will protect him, the Owner, and the Owner's agents, representatives, and employees from claims set forth below which may arise out of or result from the Contractor's operations under the Contract, whether such operations be by himself or by any Subcontractor or by anyone directly or indirectly employed by any of them, or by anyone for whose acts any of them may be liable:

- .1 Claims under workers' or workmen's compensation, disability benefit and other similar employee benefit acts (with Workmen's Compensation and Employer's Liability Insurance in amounts not less than those necessary to meet the statutory requirements of the state(s) having jurisdiction over any portion of the Work);
- .2 Claims for damages because of bodily injury, sickness or disease, or death of his employees; the Contractor will require his Subcontractors to similarly provide Workmen's Compensation Insurance for all of the latter's employees;
- .3 Claims for damages because of bodily injury, sickness or disease, or death of any person other than his employees;
- .4 Claims for damages insured by usual personal injury liability coverage which are sustained (1) by any person as a result of an offense directly or indirectly related to the employment of such person by the Contractor, or (2) by any other person;
- .5 Claims for damages, other than to the Work itself, because of injury to or destruction of tangible property, including loss of use resulting therefrom; and
- .6 Claims for damages because of bodily injury or death of any person or property damage arising out of the ownership, maintenance or use of any motor vehicle.

- 11.1.2 The insurance required by Paragraph 11.1.1 shall be primary and non-contributing to any insurance possessed or procured by the Owner, and limits of liability shall be not less than those set forth in these General Conditions of the Contract or required by law, whichever is greater.

- 11.1.3 The insurance required by the Contract shall include contractual liability insurance applicable to the Contractor's obligations under the Contract
- 11.1.4 Without limiting the above during the term of the Contract, the Contractor and each Subcontractor shall, at their own expense, purchase and maintain the following insurance with companies properly licensed by the Insurance Department of the State of North Carolina and satisfactory to the Owner.
- .1 Worker's Compensation including Occupational Disease and Employer's Liability Insurance.
 - .1 Statutory - Amount and coverage as required by State of North Carolina Worker's Compensation laws.
 - .2 Employer's Liability
 - \$1,000,000 Each Accident
 - \$1,000,000 Policy Limit
 - \$1,000,000 Each Employee
 - .2 Commercial General Liability (Occurrence Form) - The Contractor shall provide during the life of the Contract such Commercial General Liability (Occurrence Form) Insurance as shall protect him and any Subcontractor performing work under the Contract from claims for damages for Bodily Injury including accidental death, as well as from claims for Property Damage which may arise from operations under the Contract, whether such operations be by himself or by any Subcontractor or by anyone directly or indirectly employed by either of them. This insurance shall be on the Standard Insurance Services Office, Inc. (ISO) Commercial Liability Occurrence Form or other form reasonable acceptable to Owner. The Contractor shall procure insurance coverage for direct operations, sublet work, elevators, contractual liability and completed operations with limits not less than those stated below:
 - .1 A Combined Single Limit for Bodily Injury, Property Damage and Personal Injury of:
 - Limits of Insurance
 - \$2,000,000 General Aggregate (except Products – Completed Operations) Limit
 - \$2,000,000 Products – Completed Operations Aggregate Limit
 - \$1,000,000 Personal and Advertising Injury Limit
 - \$1,000,000 Each Occurrence Limit
 - .3 Property Damages, including Broad Form Property Damage and Explosion, Collapse, Underground property damage coverages, and blasting, where necessary;
 - .4 Completed Operations Liability: Continuous coverage in force for one year after completion of the Work;
 - .5 Commercial Automobile Insurance, including coverage for owned, non-owned and hired vehicles - with limits not less than those stated below:
 - .1 A Combined Single Limit for Bodily Injury and Property Damage of \$1,000,000.
 - .6 Umbrella Liability Insurance: Policy to "pay on behalf of the Insured"

Limits of Liability:

- .1 Contract Amount: \$1,000,000-\$2,000,000:
Requires Umbrella Liability Insurance Limit of \$1,000,000.
- .2 Contract Amount: \$2,000,000 and above:
Requires Umbrella Liability Insurance Limit of \$2,000,000.

- 11.1.5 The insurance required by Section 11.1 shall be written for not less than any limits of liability specified in the Contract Documents, or required by law, whichever is greater.
- 11.1.6 Certificates of Insurance acceptable to the Owner shall be filed with the Owner prior to commencement of the Work. These Certificates shall contain a provision that coverages afforded under the policies will not be canceled until at least thirty (30) days' prior written Notice has been given to the Owner. Failure to provide such Notice shall not limit the liability of the Insurer, its agents or representatives.
- 11.1.7 All insurance policies required in this Article, except Worker's Compensation and Commercial Automobile, shall name the Owner as additional named insured for the insurance.
- 11.1.8 The Contractor shall not commence the Work under the Contract until he has obtained all the insurance required hereunder and such insurance has been approved by the Owner, nor shall the Contractor allow any Subcontractor to commence work on his subcontract until all similar insurance required of the Subcontractor has been so obtained and approved. Approval of the insurance by the Owner shall not relieve or decrease the liability of the Contractor hereunder.
- 11.1.9 The Commercial General Liability and Workers Compensation Policies provided by the Contractor shall have endorsements waiving subrogation against the Owner.

11.2 PROPERTY INSURANCE

- 11.2.1 The Contractor shall purchase and at all times maintain such insurance as will protect the Contractor, the Owner, Subcontractors and Sub-subcontractors from loss or damage to the Work or property in the course of construction, including all machinery, materials and supplies on the premises or in transit thereto and intended to become a part of the finished Work until Final Completion. This insurance shall be in the form of "Builders Risk Covered Cause of Loss Form", or equivalent form, to include but not limited to theft, collapse, earth movement, flood, and portions of the Work stored on site, off site and in transit. Any deductible provision in such insurance shall not exceed ten thousand dollars (\$10,000). Notwithstanding any such deductible provision, the Contractor shall remain solely liable for the full amount of any item covered by such insurance. Such insurance shall be in the initial Contract Sum and shall be increased at Contractor's expense in the amount of all additions to the Contract Sum. Such insurance shall include interests of the Owner, the Contractor, Subcontractors and Sub-subcontractors in the Project.
- 11.2.2 Any loss insured under Paragraph 11.2.1 is to be adjusted with the Owner and made payable to the Owner as trustee for the insureds, as their interests may appear, subject to the requirements of Paragraph 11.2.4. The Contractor shall pay each Subcontractor a just share of any insurance moneys received by the Contractor, and by appropriate agreement, written where legally required for validity, shall require each Subcontractor to make payments to his Sub-subcontractors in similar manner.

- 11.2.3 The Owner and Contractor waive all rights against each other for damages caused by fire or other perils to the extent their Claims are covered by insurance obtained pursuant to this Section 11.2, or any other property insurance applicable to the Work, except such rights as they may have to the proceeds of such insurance. The Contractor shall require, by appropriate agreement, written where legally required for validity, similar waivers in favor of the Owner and the Contractor by Subcontractors and Sub-subcontractors. With respect to the waiver of rights of recovery, the term Owner shall be deemed to include, to the extent covered by property insurance applicable thereto, his consultants, employees, and agents and representatives. The Contractor waives as against any Separate Contractor described in Article 6, all rights for damages caused by fire or other perils in the same manner as is provided above as against the Owner. The Owner shall require, by appropriate agreement, written where legally required for validity, similar waivers in favor of the Contractor by any Separate Contractor and his subcontractors and sub-subcontractors.
- 11.2.4 The Owner as trustee shall have power to adjust and settle any loss with the insurers unless one of the parties in interest shall object in writing within five (5) days after the occurrence of loss to the Owner's exercise of this power, and if such objection is made, the matter shall be decided by a court of competent jurisdiction or as the parties in interest otherwise agree. The Owner as trustee shall, in that case, make settlement with the insurers in accordance with the orders of the court or as otherwise agreed by the parties in interest.
- 11.2.5 If the Owner finds it necessary to occupy or use a portion or portions of the Work prior to Substantial Completion thereof, such occupancy or use shall not commence prior to a time mutually agreed to by the Owner and Contractor and to which the insurance company or companies providing the property insurance have consented by endorsement to the policy or policies. This insurance shall not be canceled or lapsed on account of such partial occupancy or use. Consent of the Contractor and of the insurance company or companies to such occupancy or use shall not be unreasonably withheld.
- 11.2.6 The Contractor bears the risk of loss or damage to the Work, the Project, materials stored on site or off site, and Owner's improvements and property under Contractor's control, both during construction and prior to Substantial Completion.
- 11.3 EFFECT OF SUBMISSION OF CERTIFICATES
- 11.3.1 The Owner shall be under no obligation to review any Certificates of Insurance provided by the Contractor or to check or verify the Contractor's compliance with any and all requirements regarding insurance imposed by the Contract Documents. The Contractor is fully liable for the amounts and types of insurance required herein and is not excused should any policy or certificate of insurance provided by the Contractor not comply with any and all requirements regarding insurance imposed by the Contract Documents.
- 11.4 FAILURE OF COMPLIANCE
- 11.4.1 Should the Contractor fail to provide and maintain in force any and all insurance, or insurance coverage required by the Contract Documents or by law, or should a dispute arise between Owner and any insurance company of Contractor over policy coverage or limits of liability as required herein, the Owner shall be entitled to recover from the Contractor all amounts payable, as a matter of law, to Owner or any other parties, had the required insurance or insurance coverage been in force. Said recovery shall include, but is not limited to interest for the loss of use of such amounts of money, plus all attorney's fees, costs and expenses incurred in securing such determination and any other consequential damages arising out of the failure of the

Contractor or insurance company to comply with the provisions of the Contract Documents, or any policy required hereby, or any other requirements regarding insurance imposed by law. Nothing herein shall limit any damages for which Contractor is responsible as a matter of law.

11.5 OWNER'S INSURANCE

11.5.1 Property Insurance: The Owner, at his option, may purchase and maintain such insurance as will insure him against loss of use of his property due to fire or other hazards, however caused.

11.5.2 Commercial Public Liability Insurance: The Owner, at his option, may purchase and maintain insurance which will insure and protect him against claims involving bodily injury and property damage to the public. The Owner does not request his insurer to waive any right of subrogation against the Contractor from claims under this coverage.

11.6 LICENSED INSURANCE COMPANIES

11.6.1 All insurance companies providing the above insurance shall be licensed by the Insurance Department of the State of North Carolina and have a minimum AM Best "A" rating or similar rating from another rating agency reasonably acceptable to Owner.

ARTICLE 12

CHANGES IN THE WORK

12.1 GENERAL PROVISIONS RELATED TO CHANGES

12.1.1 A Construction Change Directive is a document issued pursuant to this Paragraph 12.1.1. The Owner may, at any time, without the agreement of the Contractor, by written order signed by the Owner and Design Consultant designated or indicated to be a Construction Change Directive, make any Changes in the Work or add to or subtract from the Work within the general scope of the Contract. A Change in the Work is defined as changes within the general scope of the Contract, including, but not limited to changes:

- .1 In the Specifications or Drawings;
- .2 In the sequence, method or manner of performance of the Work;
- .3 In the Owner-furnished facilities, equipment, materials, services or site; or
- .4 Directing acceleration in the performance of the Work.

12.1.2 A Change Order is a document executed pursuant to this Paragraph 12.1.2. The Owner and Contractor may agree to Changes in the Work, the Contract Sum, the Contract Time and any other change in the Contract by written agreement signed by Owner, Contractor and Design Consultant designated or indicated to be a Change Order. If the Contractor, subsequent to the issuance of a Construction Change Directive, agrees to its terms including any applicable adjustment to the Contract Sum and Contract Time, Contractor shall sign it and it shall become a Change Order.

12.1.3 The Contractor shall not be entitled to any amount for indirect costs, damages or expenses of any nature, including, but not limited to, so-called "impact" costs, labor inefficiency, wage, material or other escalations beyond the prices upon which the Proposal is based and to which

the parties have agreed pursuant to the provisions of Article 12, and which the Contractor, its Subcontractors or Sub-subcontractors or any other person may incur as a result of delays, interferences, suspensions, changes in sequence or the like, for whatever cause, whether reasonable or unreasonable, foreseeable or unforeseeable, or avoidable or unavoidable, arising from the performance of any and all Changes in the Work performed pursuant to this Article 12, unless the delay is caused solely by the Owner or its agent. It is understood and agreed that the Contractor's sole and exclusive remedy in the event the delay is caused solely by the Owner or its agent shall be recovery of his direct costs as compensable hereunder and an extension of the Contract Time, but only in accordance with the provisions of the Contract Documents. The phrase "Owner or its agent" as used in the Contract, does not include the Prime Contractors or their Subcontractors.

- 12.1.4 No Claim by the Contractor shall be allowed if asserted after final payment under this Contract. No Claim relating to or flowing from a particular change shall be allowed after execution of the Change Order relating to that change or commencement of the change by the Contractor except as specifically provided in Paragraph 12.2.4.
- 12.1.5 If any dispute should arise between the parties with respect to an increase or decrease in the Contract Sum or an expansion or contraction in the Contract Time as a result of a Change in the Work, the Contractor shall not suspend performance of a Change in the Work or the Work itself unless otherwise so ordered by the Owner in writing. The Owner shall, however, pay to the Contractor up to the Owner's reasonable estimated value of the Change in the Work, regardless of the dispute, if said Change in the Work will result in an increase in the Contract Sum; and the Owner shall have the right to withhold payment from the Contractor in an amount up to the Owner's reasonable estimated value of the Change in the Work, regardless of the dispute, if said Change in the Work will result in a decrease in the Contract Sum.
- 12.1.6 No Change in the Work shall be performed without a fully executed Change Order to the Contract a fully executed Construction Change Directive or other Modification to the Contract.
- 12.1.7 If the Contractor intends to assert a Claim under this Article, he must, within ten (10) days after receipt of a Construction Change Directive, Notify the Owner by written statement setting forth the specific nature and cost of such Claim, unless this period is extended by the Owner. The statement of Claim shall include all direct, indirect and impact costs associated with the change, as well as the Contractor's estimate of the schedule impact of the change, if any. The Contractor and its Subcontractors shall not be entitled to reimbursement for any Claims that are not submitted in strict conformance with the Contract. The Contractor shall indemnify and hold the Owner harmless against any Claims by Subcontractors that are waived because they are not submitted in strict conformance with the Contract.
- 12.2 OWNER DIRECTED CHANGES REQUIRING AN INCREASE IN CONTRACT SUM.
(For decreases in Contract Sum, refer to Section 12.6)
- 12.2.1 If the Change in the Work will result in an increase in the Contract Sum, the Owner shall have the right to require the performance thereof on a lump sum basis, a unit price basis or a time and material basis, all as hereinafter more particularly described (the right of the Owner as aforesaid shall apply with respect to each such Change in the Work).

If the Owner elects to have the Change in the Work performed on a lump sum basis, its election shall be based on a lump sum Proposal which shall be submitted by the Contractor to the Owner within ten (10) days of the Contractor's receipt of a request therefore (but the Owner's request for a lump sum Proposal shall not be deemed an election by the Owner to have the Change in

the Work performed on a lump sum basis). The Contractor's Proposal shall be itemized and segregated by labor and materials for the various components of the Change in the Work (no aggregate labor total will be acceptable) and shall be accompanied by signed Proposals of any Subcontractors who will perform any portion of the Change in the Work and of any persons who will furnish materials or equipment for incorporation therein. The Proposal shall also include the Contractor's estimate of the time required to perform said changes. The Contractor shall provide any documentation that may be requested by the Owner or Design Consultant to support the change proposal, including but not limited to payroll records, insurance rates, material quotes, and rental quotes.

The portion of the Proposal relating to labor, whether by the Contractor's forces or the forces of any of its Subcontractors, may include reasonably anticipated gross wages of job site labor, including foremen, who will be directly involved in the Change in the Work (for such time as they will be so involved), plus payroll costs (including premium costs of overtime time, if overtime is anticipated, Social Security, Federal or State unemployment insurance taxes and fringe benefits required by collective bargaining agreements entered into by the Contractor or any such Subcontractor in connection with such labor) and up to fifteen percent (15%) of such anticipated gross wages, but not payroll costs, as overhead and profit for the Contractor or any such Subcontractor, as applicable (said overhead and profit to include all supervision except foremen). Payroll costs are limited to 39% of the net pay of the worker.

The portion of the Proposal relating to materials may include the reasonably anticipated direct costs to the Contractor or to any of its Subcontractors of materials to be purchased for incorporation in the Change in the Work, plus transportation and applicable sales and use taxes and up to fifteen percent (15%) of said direct material costs as overhead and profit for the Contractor or any such Subcontractor (said overhead and profit to include all small tools), and may further include the Contractor's and any of its Subcontractor's reasonably anticipated rental costs in connection with the Change in the Work (either actual or discounted local published rates), plus up to eight percent (8%) thereof as overhead and profit for the Contractor or any such Subcontractors, as applicable. The Contractor shall provide an itemized breakdown of all transportation and shipping costs, including receipts documenting the expenses. Notwithstanding the above, overhead and profit shall not be applied to any sales tax paid for any purpose or to any transportation or shipping costs incurred by the Contractor or any subcontractor. If any of the items included in the lump sum Proposal are covered by unit prices contained in the Contract Documents, the Owner may, if it requires the Change in the Work to be performed on a lump sum basis, elect to use these unit prices in lieu of the similar items included in the lump sum Proposal, in which event an appropriate deduction will be made in the lump sum amount prior to the application of any allowed overhead and profit percentages. No overhead and profit shall be applied to any unit prices.

The lump sum Proposal may include up to eight percent (8%) of the amount which the Contractor will pay to any of its Subcontractors for Changes in the Work as overhead and profit for the Contractor. The Contractor shall not be reimbursed for the costs of the Subcontractors' Payment and Performance Bonds, as such bonding is not required by the Owner.

12.2.2 In the event that the Contractor fails to submit his Proposal within the designated period, the Owner may order the Contractor to proceed with the Change to the Work and the Contractor shall so proceed. The Owner shall unilaterally determine the reasonable cost and time to perform the Work in question, which determination shall be final and binding upon the Contractor. The Contractor may dispute such action in accordance with the Article 15.

12.2.3 In the event that the parties are unable to agree as to the reasonable cost and time to perform the

Change in the Work based upon the Contractor's Proposal and the Owner does not elect to have the Change in the Work performed on a time and material basis, the Owner may choose to make a determination of the reasonable cost and time to perform the Change in the Work, based upon its own estimates, the Contractor's submission or a combination thereof. A Construction Change Directive shall be issued in this case for the amounts of cost and time determined by the Owner and shall become final and binding upon the Contractor, subject to Contractor's right to dispute such action in accordance with Article 15. Owner has the right to direct by Construction Change Directive a Change in the Work, which is the subject of such Change Order. Failure of the parties to reach agreement regarding the cost and time of the performing the Construction Change Directive, shall not relieve the Contractor from performing the Change in the Work promptly and expeditiously.

12.2.3.1 The Owner reserves the right to reject the Contractor's Proposal for a Change in the Work and to elect to perform said Work using a Separate Contractor. Under such circumstances, all provisions of Article 6 shall be in force.

12.2.4 If the Owner elects to have the Change in the Work performed on a time and material basis, the same shall be performed, whether by the Contractor's forces or the forces of any of its Subcontractors or Sub-subcontractors, at actual cost to the entity performing the Change in the Work (without any charge for administration, clerical expense, supervision or superintendence of any nature whatsoever, including foremen, or the cost, use or rental of tools or plant), plus fifteen percent (15%) thereof as the total overhead and profit (except that said fifteen percent (15%) shall not be applied against any payroll costs, as set forth in Paragraph 12.2.1.) The Contractor shall submit to the Owner daily time and material tickets, on a daily basis to include the identification number assigned to the Change in the Work, the location and description of the Change in the Work, the classification of labor employed (and names and social security numbers), the materials used, the equipment rented (not tools) and such other evidence of cost as the Owner may require. The Owner may require authentication of all time and material tickets and invoices by persons designated by the Owner for such purpose. The failure of the Contractor to secure any required authentication shall, if the Owner elects to treat it as such, constitute a waiver by the Contractor of any Claim for the cost of that portion of the Change in the Work covered by a non-authenticated ticket or invoice; provided, however, that the authentication of any such ticket or invoice by the Owner shall not constitute an acknowledgment by the Owner that the items thereon were reasonably required for the Change in the Work.

12.2.5 No overhead and profit will be paid by the Owner on account of a Change in the Work except as specifically provided in Section 12.2. Overhead and profit, as allowed under Section 12.2, shall be deemed to include all costs and expenses which the Contractor or any of its Subcontractors may incur in the performance of a Change in the Work and which are not otherwise specifically recoverable by them pursuant to Section 12.2.

12.3 CONTRACTOR NOTICE OF CHANGE

12.3.1 If the Contractor or any of its Subcontractors asserts that any event or occurrence has caused a Change in the Work which change causes an increase or decrease in the Contractor's or its Subcontractors cost or the time required for the performance of any part of the Work under the Contract, including Work not affected directly by the change, the Contractor shall, within ten (10) days of such event, give the Owner written Notice as herein required. Said Notice shall include the instructions or circumstances that are the basis of the Claim and the Contractor's best estimate of the cost and time involved.

12.4 MINOR CHANGES IN THE WORK

12.4.1 The Owner shall have authority to order minor Changes in the Work not involving an adjustment in the Contract Sum or an extension of the Contract Time and not inconsistent with the intent of the Contract Documents. Such changes shall be effected by written order, and shall be binding on the Owner and the Contractor. The Contractor shall carry out such written orders promptly.

12.4.2 The Contractor shall not perform any Changes in the Work unless authorized in writing by the Design Consultant or Owner.

12.5 DIFFERING SITE CONDITIONS

12.5.1 Should the Contractor encounter subsurface and/or latent conditions at the site materially differing from those shown on the Drawings or indicated in the Specifications or differing materially from those ordinarily encountered and generally recognized as inherent in work of the character provided for in this Contract, or different from that shown on surveys or tests provided in the bid materials at the time the Owner solicited bids from the construction of the Project, he shall immediately give Notice to the Owner of such conditions before they are disturbed. The Owner and the Design Consultant shall thereupon promptly investigate the conditions and if they find that they materially differ from those shown on the Drawings or indicated in the Specifications, they shall at once make such changes in the Drawings and/or Specifications as they may find necessary. Any increase or decrease of cost resulting from such changes shall be adjusted in the manner provided herein for adjustments as to extra and/or additional work and changes. However, neither the Owner nor the Design Consultant shall be liable or responsible for additional work, costs or Changes to the Work due to material differences between actual conditions and any geotechnical, soils and other reports, surveys and analyses made available for the Contractor's review at the time the Owner solicited bids for the construction of the Project.

12.6 OWNER DIRECTED CHANGES REQUIRING A DECREASE IN CONTRACT SUM.

12.6.1 If the Change in the Work will result in a decrease in the Contract Sum, the Owner may request a quotation by the Contractor of the amount of such decrease. The following provisions shall apply:

The portion of the Proposal relating to labor, whether by the Contractor's forces or the forces of any of its Subcontractors, shall include reasonably anticipated gross wages of job site labor, including foremen, who would have been directly involved in the Work that has been deleted from the Contract, (for such time as they would have been so involved), plus payroll costs (including premium costs of overtime time, if overtime was anticipated, Social Security, Federal or State unemployment insurance taxes and fringe benefits required by collective bargaining agreements entered into by the Contractor or any such Subcontractor in connection with such labor) and seven percent (7%) of such anticipated gross wages, but not payroll costs, as overhead and profit not incurred or earned by the Contractor or any such Subcontractor, as applicable (said overhead and profit to include all supervision except foremen).

The portion of the Proposal relating to materials shall include the reasonably anticipated direct costs which would have been incurred by the Contractor or to any of its Subcontractors of materials which would have been purchased for incorporation in the Work but which has been deleted from the Contract, plus transportation and applicable sales and use taxes which will be avoided and seven percent (7%) of said direct material costs as overhead and profit not incurred or earned by the Contractor or any such Subcontractor (said overhead and profit to include all small tools), and shall further include the Contractor's and any of its Subcontractor's reasonably

anticipated rental costs which will be avoided (either actual or discounted local published rates), plus five percent (5%) thereof as overhead and profit not incurred or earned by the Contractor or any such Subcontractors, as applicable. If any of the items included in the lump sum Proposal are covered by unit prices contained in the Contract Documents, the Owner may elect to use these unit prices in determining the amount of reduction to the Contract Sum as a result of a deletion of Work from the Contract. No overhead and profit shall be applied to any unit prices for purposes of calculation such reduction in the Contract Sum.

The lump sum Proposal for Work which would have been performed by any Subcontractors shall include four percent (4%) of that amount as an estimate of the Contractor's overhead and profit that will not be earned by Contractor due to the decrease in the Contract Sum.

The Contractor's quotation shall be forwarded to the Owner within ten (10) days of the Owner's request and, if acceptable to the Owner, shall be incorporated in the Change Order. If not acceptable, the parties shall make every reasonable effort to agree as to the amount of such decrease, which may be based on a lump sum properly itemized, on unit prices stated in the Contract Documents and/or on such other basis as the parties may mutually determine. If the parties are unable to so agree, the amount of such decrease shall be the total of the estimated reduction in actual cost of the Work, as determined by the Owner in its reasonable judgment, plus overhead and profits stated above. This shall become final and binding upon the Contractor, subject to Contractor's right to dispute such action in accordance with the Article 15.

ARTICLE 13

UNCOVERING AND CORRECTION OF WORK

13.1 UNCOVERING OF WORK

13.1.1 If any portion of the Work is covered contrary to the request of the Owner or the Design Consultant or to requirements specifically expressed in the Contract Documents or to requirements of applicable construction permits, it must, if required in writing by the Owner, be uncovered for his observation and shall be replaced at the Contractor's expense.

13.1.2 If any other portion of the Work has been covered which the Design Consultant or the Owner has not specifically requested to observe prior to being covered, either may request to see such portion of the Work and it shall be uncovered by the Contractor. If such Work be found in accordance with the Contract Documents, the cost of uncovering and replacement shall, by appropriate Change Order, be charged to the Owner. If such Work be found not in accordance with the Contract Documents, the Contractor shall pay such costs unless it is found that this condition was caused by the Owner, in which event the Owner shall be responsible for the payment of such costs. If such condition was caused by a Separate Contractor, Contractor may proceed against and only against, said Separate Contractor as provided in Article 6. Any costs to the Owner pursuant to this Paragraph shall be determined in accordance with the provisions of Article 12.

13.2 CORRECTION OF WORK

13.2.1 The Contractor shall promptly reconstruct, replace or correct portions of the Work rejected by the Design Consultant or Owner as defective or as failing to conform to the Contract Documents or as not in accordance with the guarantees and warranties specified in the Contract Documents whether observed before or after Substantial Completion and whether or not fabricated, installed or completed. The Contractor shall bear all costs of correcting such rejected portions of the

Work, including compensation for the Design Consultant's and the Owner's additional construction management services made necessary thereby.

- 13.2.2 The Contractor, unless removal is waived by the Owner, shall remove from the site all portions of the Work which are defective or non-conforming, or if permitted or required, he shall correct such portions of the Work in place at his own expense promptly after receipt of Notice, and such rejected Work shall not thereafter be tendered for acceptance unless the former rejection or requirement for correction is disclosed.
- 13.2.3 If the Contractor does not proceed with the correction of such defective or non-conforming portions of the Work within a reasonable time fixed by written Notice from the Owner or Design Consultant, the Owner may either (1) by separate contract or otherwise replace or correct such portions of the Work and charge the Contractor the cost incurred by the Owner thereby and remove and store the materials or equipment at the expense of the Contractor, or (2) terminate this Contract for default as provided in Section 14.3, or both, or take any other measure allowed by law.
- 13.2.4 The Contractor shall bear the cost of making good all work of the Owner or Separate Contractors destroyed or damaged by such correction or removal.
- 13.2.5 Nothing contained in this Section 13.2 shall be construed to establish a period of limitation with respect to any other obligation which the Contractor might have under the Contract Documents, including Section 4.6 hereof. The establishment of the time period of one year after the date of Substantial Completion or such longer period of time as may be prescribed by law or by the terms of any warranty required by the Contract Documents relates only to the specific obligation of the Contractor to correct the Work, and has no relationship to the time within which his obligation to comply with the Contract Documents may be sought to be enforced, nor to the time within which proceedings may be commenced to establish the Contractor's liability with respect to his obligations.
- 13.3 ACCEPTANCE OF DEFECTIVE OR NON-CONFORMING WORK
- 13.3.1 If the Owner prefers to accept defective or non-conforming Work, he may do so instead of requiring its removal and correction, in which case a Change Order will be issued to reflect a reduction in the Contract Sum where appropriate and equitable, or the Owner may elect to accept payment in materials or services, in lieu of a reduction in the Contract Sum. If the amount of a reduction is determined after final payment, it shall be paid to the Owner by the Contractor.

ARTICLE 14

TERMINATION OF THE CONTRACT

- 14.1 TERMINATION BY THE CONTRACTOR
- 14.1.1 If the Work is stopped for a period of one hundred twenty (120) days by the Owner or under an order of any court or other public authority having jurisdiction, or as a result of an act of government, such as a declaration of a national emergency making materials unavailable, and through no act or fault of the Contractor or a Subcontractor or their agents or employees or any other persons performing any of the Work under a contract with the Contractor, then the Contractor may, upon seven (7) additional days' written Notice to the Owner and the Design Consultant, terminate the Contract and recover from the Owner payment on a quantum merit basis, for all Work executed for which Contractor has not previously been paid, less any amounts

Contractor may owe Owner under the Contract Documents and less any amounts Owner is entitled to withhold from Contractor or backcharge to the Contractor under the Contract Documents or pursuant to law. The Contractor shall not be entitled to collect and hereby expressly waives any overhead or profit on Work not performed and any damages related to that portion of the Contract which has been terminated.

14.2 TERMINATION FOR CONVENIENCE OF THE OWNER

14.2.1 The Owner may, at any time upon ten (10) days written Notice to the Contractor and to the Contractor's Surety, which Notice shall specify that portion of the Work to be terminated and the date said termination is to take effect, terminate (without prejudice to any right or remedy of the Owner) the whole or any portion of the Work for the convenience of the Owner. The Contractor's sole remedy, in the event of such termination, will be the allowable termination costs permitted by Section 14.4. Contractor shall include termination clauses identical to Article 14 in each of his subcontracts.

14.3 DEFAULT TERMINATION

14.3.1 Ten (10) days after written Notice is mailed to the Contractor and to the Contractor's Surety, the Owner may terminate (without prejudice to any right or remedy of the Owner or any subsequent buyer of any portion of the Work) the employment of the Contractor and his right to proceed either as to the whole or any portion of the Work required by the Contract Documents and may take possession of the Work and complete the Work by contract or otherwise in any one of the following circumstances:

- .1 If the Contractor or its Surety refuses or fails to prosecute the Work or any separable part thereof with such diligence as will ensure the Substantial and Final Completion of the Work by the dates specified in the Supplemental Conditions for Substantial and Final Completion or fails to complete the Work or remedy a default within said period;
- .2 If the Contractor is in material default in carrying out any provisions of the Contract;
- .3 If the Contractor fails to supply a sufficient number of properly skilled workers or proper equipment or materials;
- .4 If the Contractor fails to make prompt payment to Subcontractors or for materials or labor, unless he otherwise provides the Owner satisfactory evidence that payment is not legally due;
- .5 If the Contractor disregards laws, permits, ordinances, rules, regulations or orders of any public authority having jurisdiction, or fails to follow the instructions of the Owner;
- .6 If the Contractor substantially violates any provisions of the Contract Documents; or
- .7 If the Contractor refuses or fails to properly schedule, plan, coordinate and execute the Work, as specified herein, so as to perform the Work within the specified Completion Dates, or to provide scheduling or related information, revisions and updates as required by the Contract Documents.

14.3.2 The right of the Contractor to proceed shall not be so terminated under this Section 14.3 if the delays in the completion of the Work are due to unforeseeable causes beyond the control and without the fault or negligence of the Contractor or his Subcontractors as specifically set forth

in Section 8.3 hereof.

- 14.3.3 If, after the Contractor has been terminated for default pursuant to Section 14.3, it is determined that none of the circumstances set forth in Paragraph 14.3.1 exist, then such termination shall be considered a termination for convenience pursuant to Section 14.2. In such case, the Contractor's sole remedy will be the costs permitted by Section 14.4.
- 14.3.4 If the Owner so terminates the employment of the Contractor due to the Contractor's default, the Contractor shall not be entitled to receive any further payment until the Work is finished. If the unpaid balance of the compensation to be paid to the Contractor hereunder shall exceed the expense of so completing the Work (including compensation for additional managerial, administrative, consultant and inspection services, attorney's fees and any damages for delay) such excess shall be paid to the Contractor.
- 14.3.5 If such expenses referenced in Paragraph 14.3.1, shall exceed the unpaid balance, the Contractor and his sureties shall be liable to the Owner for such excess. If the right of the Contractor to proceed with the Work is partially or fully terminated, the Owner may take possession of and utilize in completing the Work such materials, appliances, supplies, plant and equipment as may be on the site of the terminated portion of the Work and necessary for the completion of the Work. If the Owner does not fully terminate the right of the Contractor to proceed, the Contractor shall continue to perform the part of the Work that is not terminated.
- 14.3.6 If the Owner terminates the whole or any part of the Work pursuant to Section 14.3, the Owner may procure, upon such terms and in such manner as the Owner may deem appropriate, supplies or services similar to those so terminated, and the Contractor shall be liable to the Owner for any excess costs for such similar supplies or services. The Contractor shall continue the performance of the Contract to the extent not terminated hereunder.

14.4 ALLOWABLE TERMINATION COSTS

- 14.4.1 If the Owner terminates the whole or any portion of the Work pursuant to Section 14.2, then the Owner shall only be liable to the Contractor for those costs reimbursable to the Contractor in accordance with Paragraph 14.4.2, plus a markup of ten percent (10%) for profit and overhead on the actual fully accounted costs specified under Paragraph 14.4.2; provided however, that if there is evidence that the Contractor would have sustained a loss on the entire Contract had it been completed, no profit or overhead shall be included or allowed hereunder for the Work performed and an appropriate adjustment shall be made reducing the amount of the settlement to reflect the indicated rate of loss. Under no circumstances shall the Contractor be entitled to any loss profit on the Work terminated pursuant to Section 14.2.
- 14.4.1.1 After receipt of a Notice of Termination, the Contractor shall submit to the Owner his termination Claim, in the form and with certification prescribed by the Owner. Such Claim shall be submitted promptly but in no event later than three (3) months from the effective date of termination, unless one or more extensions in writing are granted by the Owner upon request of the Contractor made in writing within such three (3) month period or authorized extension thereof. However, if the Owner determines that the facts justify such action, he may receive and evaluate any such termination Claim at any time after such three (3) month period or any extension thereof. Upon failure of the Contractor to submit his termination Claim within the time allowed, the Owner may determine, on the basis of information available to him, the amount, if any, due to the Contractor by reason of the termination and such termination shall be final and binding on the Contractor.

- 14.4.2 If the Owner terminates the whole or any portion of the Work pursuant to Section 14.2, the Owner shall pay the Contractor an amount for supplies, services, or property accepted by the Owner, and which is in accordance with the Contract Documents, in an amount as if the Contract had not been terminated. In addition, in such event, the Owner shall pay to Contractor an amount representing Contractor's actual cost, excluding any overhead and profit for the items and things specified in Subparagraph 14.5.1.6 and not heretofore paid for, appropriately adjusted for any saving of freight or other charges. Under no circumstances shall the Contractor be entitled to any loss profit on the Work terminated pursuant to Section 14.2.
- 14.4.2.1 The Contractor agrees that neither the Owner nor the Design Consultant will be liable for payments to Contractors or Subcontractors pursuant to Section 14.4.2 unless each contract and subcontract contains termination provisions identical to those set forth in this Article 14. The Owner and the Design Consultant will not be liable to the Contractor or any of the Subcontractors for any costs associated with termination if the contract or subcontract of the party involved does not include the required termination language.
- 14.4.3 In arriving at any amount due the Contractor pursuant to Section 14.4, there shall be deducted the following:
- .1 All unliquidated advance or other payments on account theretofore made to the Contractor applicable to the terminated portion of the Contract;
 - .2 Any Claim which the Owner may have against the Contractor;
 - .3 Such amount as the Owner determines to be necessary to protect the Owner against loss because of outstanding or potential liens or claims; and
 - .4 The agreed price for, or the proceeds of sale of, any materials, supplies or other things acquired by the Contractor sold, pursuant to the provisions of Subparagraph 14.5.1.7, and not otherwise recovered by or credited to the Owner, or returned for a refund by the Contractor.
 - .5 All other amounts the Owner is entitled to withhold from the Contractor or charge to the Contractor pursuant to the Contract or as allowed by applicable law.
- 14.4.4 The total sum to be paid to the Contractor under Section 14.4 shall not exceed the Contract Sum as reduced by the amount of payments otherwise made or to be made for Work not terminated and as otherwise permitted by the Contract. Except for normal spoilage, and except to the extent that the Owner shall have otherwise expressly assumed the risk of loss, there shall be excluded from the amounts payable to the Contractor, as provided in Paragraph 14.4.2, the fair value, as determined by the Owner, of property which is destroyed, lost, stolen or damaged so as to become undeliverable to the Owner, or to a buyer pursuant to Subparagraph 14.5.1.7.

14.5 GENERAL TERMINATION PROVISIONS

- 14.5.1 After receipt of a Notice of termination from the Owner, pursuant to Section 14.2 or 14.3, and except as otherwise directed by the Owner, the Contractor shall:
- .1 Stop work under the Contract on the date and to the extent specified in the Notice of termination;
 - .2 Place no further orders or subcontracts for materials, services or facilities, except as may

be necessary for completion of such portion of the Work under the Contract as is not terminated;

- .3 Terminate all orders and subcontracts to the extent that they relate to the performance of the Work terminated by the Notice of termination;
- .4 At the option of the Owner, and in lieu of terminating such orders and subcontracts, assign to the Owner in the manner, at the times and to the extent directed by the Owner in writing, all of the rights in the such orders and subcontracts,
- .5 Settle all outstanding liabilities and all Claims arising out of such termination or orders and subcontracts, with the approval or ratification of the Owner in writing, to the extent he may require, which approval or ratification shall be final for all the purposes of this Article;
- .6 Transfer title and deliver to the entity or entities designated by the Owner, in the manner, at the times and to the extent directed by the Owner to the extent specifically produced or specifically acquired by the Contractor for the performance of such portion of the Work as had been terminated, the following:
 - (1) The fabricated or unfabricated parts, Work in process, partially completed supplies and equipment, materials, parts, tools, dies, jigs and other fixtures, completed Work, supplies and other material produced as part of, or acquired in connection with the performance of, the Work terminated by the Notice of termination; and
 - (2) The completed or partially completed plans, drawings, information, releases, manuals and other property related to the Work and which, if the Contract had been completed, would have been required to be furnished to the Owner;
- .7 Use his best efforts to return for a refund or sell, in the manner, at the times, to the extent and at the price or prices directed or authorized by the Owner, any property of the types referred to in Subparagraph 14.5.1.6; provided, however, that the Contractor:
 - (1) Shall not be required to extend credit to any buyer, and
 - (2) May acquire any such property under the conditions prescribed by and at a price or prices approved by the Owner in writing; and provided further that the proceeds of any such transfer or disposition shall be applied in reduction of any payments to be made by the Owner to the Contractor under the Contract or shall otherwise be credited to the Contract Sum covered by the Contract or paid in such other manner as the Owner may direct;
- .8 Complete performance of such part of the Work as shall not have been terminated by the Notice of termination;
- .9 Take such action as may be necessary, or as the Owner may direct, for the protection and preservation of the property related to the Contract which is in the possession of the Contractor and in which the Owner has or may acquire an interest; and
- .10 Otherwise mitigate any damages Contractor claims to suffer as a result of a termination.

14.5.2 The Contractor shall, from the effective date of termination until the expiration of three (3) years after final settlement under the Contract, preserve and make available to the Owner, at all

reasonable times at the office of the Contractor, but without direct charge to the Owner, all his books, records, documents and other evidence bearing on the costs and expenses of the Contractor under the Contract and relating to the Work terminated hereunder, or, to the extent approved by the Owner, photographs, micro-photographs or other authentic reproductions thereof.

- 14.5.3 If the termination, pursuant to Section 14.2, be partial, the Contractor may file with the Owner a Claim for an equitable adjustment of the price or prices specified in the Contract relating to the continued portion of the Contract (the portion not terminated by the Notice of termination), and such equitable adjustment as may be agreed upon shall be made in such price or prices. Any Claim by the Contractor for an equitable adjustment under this Paragraph must be asserted within thirty (30) days from the effective date of the Notice of termination.
- 14.5.4 The Contractor shall refund to the Owner any amounts paid by the Owner to the Contractor in excess of costs reimbursable under Section 14.4.
- 14.5.5 The Contractor shall be entitled to only those damages and that relief from termination by the Owner as specifically provided in Article 14.

ARTICLE 15

DISPUTE RESOLUTION

15.1 INITIATING CLAIMS

- 15.1.1 Claims must be initiated by written Notice to the Owner and to the party against whom the Claim is made with a copy to the Design Consultant. The responsibility to substantiate Claims shall rest with the party making the Claim.
- 15.1.2 Nothing in the Contract shall be construed as meaning that the Owner's assessment of Liquidated Damages is a Claim as defined herein, or that the Owner has the burden of proof to assess Liquidated Damages. Should the Owner assess Liquidated Damages, the burden of proving that such damages should not have been assessed shall rest upon the Contractor.

15.2 RESOLUTION OF CLAIMS AND DISPUTES BETWEEN CONTRACTOR AND OWNER

- 15.2.1 Claims by Contractor against Owner and by Owner against Contractor, including those alleging an error or omission by the Design Consultant shall be subject to the process set forth in this Section 15.2. Such Claims shall be referred initially to the Design Consultant for a decision. A final decision by the Design Consultant, or the failure of the Design Consultant to issue a final decision shall be required as a condition precedent to mediation or litigation of all such Claims arising prior to the date final payment is due. The Design Consultant will initially decide disputes between Owner and Contractor.
- 15.2.2 The Design Consultant will review Claims by Contractor and Owner against each other and within twenty (20) days of the receipt of the written Claim and take one or more of the following actions:
- .1 Request additional supporting data from the claimant or a response with supporting data from the other party;
 - .2 Reject the Claim in whole or in part;

- .3 Approve the Claim;
 - .4 Suggest a compromise; or
 - .5 Advise the parties that the Design Consultant is unable to resolve the Claim if the Design Consultant lacks sufficient information to evaluate the merits of the Claim or if the Design Consultant concludes that it would be inappropriate for the Design Consultant to resolve the Claim.
- 15.2.3 In evaluating Claims made under this Section 15.2, the Design Consultant may, but shall not be obligated to, consult with or seek information from either party or from persons with special knowledge or expertise who assist the Design Consultant in rendering a decision.
- 15.2.4 If the Design Consultant requests a party to provide a response to a Claim under this Section 15.2, or to furnish additional supporting data, such party shall respond, within ten (10) days after receipt of such request, and shall within such time period, either provide a response to the requested supporting data, advise the Design Consultant when the response or supporting data will be furnished, or advise the Design Consultant that no supporting data will be furnished. Upon receipt of the response or supporting data, if any, the Design Consultant will either reject or approve the Claim in whole or in part.
- 15.2.5 The Design Consultant will approve or reject Claims under this Section 15.2 by written decision, which shall state the reason thereof and which shall notify the parties of any change in the Contract Sum or Contract Time or both. The approval or rejection of a Claim by the Design Consultant under this Section 15.2 shall be final and binding on the parties but subject to mediation and litigation.
- 15.2.6 When a written decision of the Design Consultant under this Section 15.2 states that the decision is final but subject to mediation, then a demand for mediation of a Claim covered by such decision must be made within thirty (30) days after the date on which the party making the demand receives the final written decision. Any failure to demand mediation within said thirty (30) days' period shall result in the Design Consultant's decision becoming final and binding to all parties. Claims not resolved in mediation shall be subject to litigation if in accordance with the applicable statutes of limitation and repose.
- 15.2.7 Upon receipt of a Claim under Section 15.2 against the Contractor or at any time thereafter, the Design Consultant or the Owner may, but is not obligated to, notify the Surety, if any, of the nature and amount of the Claim. If the Claim relates to a possibility of a Contractor's default, the Design Consultant or the Owner may, but are not obligated to, notify the Surety and request the Surety's assistance in resolving the controversy.
- 15.2.8 If the Design Consultant deems that a Claim under this Section 15.2 is valid, the Design Consultant shall require all parties to the dispute to share the cost of the Design Consultant's review equitably. If the Design Consultant deems that a Claim under this Section 15.2 is invalid, the Design Consultant shall require the complaining party to bear the cost of the Design Consultant's review. In any event, the Design Consultant may require the complaining party to submit a deposit equivalent to the Design Consultant's hourly rate multiplied by the amount of time the Design Consultant estimates, in the Design Consultant sole discretion, that will be necessary to review the Claim. The Design Consultant shall return any unused portion of this initial deposit to the complaining party following the Design Consultant's completion of the Design Consultant's review of the Claim. Nothing in these procedures shall entitle the Design

Consultant to compensation for additional services from the Owner that is not authorized pursuant to the terms and conditions of the Agreement for Design Consultant Services.

15.3 TIME LIMITS ON CLAIMS

15.3.1 Unless a shorter time is provided in the Contract Documents, Claims by Contractor or any party except Owner must be initiated within twenty (20) days after occurrence of the event giving rise to such Claim or within twenty (20) days after the claimant first recognizes the condition giving rise to the Claim, whichever is later. Claims against the Owner shall be initiated in strict conformance with the Contract Documents. Nothing in these procedures shall extend the period within or the manner in which Claims against the Owner must be submitted. Claims must be initiated by written Notice to the Owner and written notice to the other party and to the Design Consultant. Any Claim against the Owner that is not initiated within the applicable time period is waived. Claims by Owner may be made at any time within the applicable statute of limitations and repose.

15.4 CONTINUING CONTRACT PERFORMANCE

15.4.1 Pending final resolution of a Claim, the Contractor shall proceed diligently with the performance of the Contract, unless instructed otherwise in writing by the Owner.

15.5 MEDIATION

15.5.1 As required by N.C.G.S 143-128 (f1), any Claim as defined herein, which exceeds fifteen thousand dollars(\$15,000.00), and which concerns a party involved in the Project, including the Owner, Contractor, Design Consultant, any construction manager, Separate Contractors, or first and lower tier Subcontractors and which arise out of the Contract or the construction process, except those waived Claims shall, be subject to mediation as a condition precedent to the institution of legal proceedings by any party, except that any party may institute legal proceedings or perfect any mechanic's or materialmen's lien in order to meet any applicable statute of limitations or similar deadline prior to engaging in mediation.

15.5.2 The parties shall endeavor to resolve their Claims under this Section 15.5 by mediation which, unless the parties mutually agree otherwise, shall be in accordance with the rules established by the Owner.

15.5.3 The parties shall share cost of the mediation equally except that if the Owner is a party to the dispute, the Owner shall pay at least one third of the cost of the mediation.

15.5.4 The mediation shall be held in a place where the Project is located, unless another location is mutually agreed upon.

15.5.5 Agreements reached in mediation shall be enforceable as settlement agreements in any court having jurisdiction thereof.

END OF GENERAL CONDITIONS

GO TO NEXT PAGE

SECTION SC

SUPPLEMENTAL CONDITIONS

GENERAL CONDITIONS

Document GC, GENERAL CONDITIONS OF THE CONTRACT FOR CONSTRUCTION, constitutes the General Conditions of this Contract, and is hereinafter called "General Conditions." The General Conditions are further revised and supplemented by the provisions of these Supplemental Conditions. The General Conditions and the Supplemental Conditions are applicable to all of the Work under this contract and shall apply to the Contractor and all Subcontractors and Sub-subcontractors.

SUPPLEMENTS:

The following supplements modify, change, delete, or add to the General Conditions. Where any article of the General Conditions is modified or any paragraph deleted, subparagraph or clause thereof is modified, or deleted by these supplements, the unaltered provisions of such article, paragraph, subparagraph or clause shall remain in effect. If there is a discrepancy between the General Conditions and these Supplemental Conditions, the Supplemental Conditions shall control.

ARTICLE 1 - CONTRACT DOCUMENTS

ADD THE FOLLOWING TO 1.3.1:

1.3.1.1 The Contractor will be furnished with one set drawings and specifications for free.

ARTICLE 2 - ARCHITECT

ADD THE FOLLOWING TO PARAGRAPH 2.1:

Design Consultant:

Hite Associates, PC
2600 Meridian Drive
Greenville, NC 27834

ARTICLE 4 – CONTRACTOR

ADD THE FOLLOWING AFTER THE FIRST SENTENCE OF PARAGRAPH 4.24:

The Owner's policies are available for review at the Central Office of Beaufort County Schools

ARTICLE 7 – MISCELLANEOUS PROVISIONS

ADD THE FOLLOWING TO THE END OF 7.1.1

The Contractor and Owner agree that Beaufort County, North Carolina shall be the proper venue for any litigation arising out of this Agreement.

ARTICLE 8 - TIME

ADD THE FOLLOWING TO PARAGRAPH 8.2:

8.2.4 The schedule below contains certain specific dates in addition to date of Notice to Proceed and Time for Completion. These dates shall be adhered to and are the last acceptable dates unless modified by mutual agreement between the Contractor and the Owner. All dates indicate midnight unless otherwise stipulated. The only exceptions to this schedule are defined in the General Conditions and Supplemental Conditions under Paragraph 8.3 DELAYS AND EXTENSIONS OF TIME.

Notice of Intent to Award – [Insert Date]
Return of Owner Contractor Agreement by Contractor – [Insert Date]
Notice to Proceed – [Insert Date]
Substantial Completion – [Insert Date]
Completion of all Commissioning – [Insert Date]
Final Completion – [Insert Date]

8.2.4.1 The Owner reserves the right to withhold the issuance of Notice to Proceed by up to **forty-five (45)** days. For each day that Notice to Proceed is withheld pursuant to this Subparagraph, the dates established for Substantial Completion and Final Completion shall be adjusted. The contractor shall not be entitled to additional compensation if the owner withholds the issuance of Notice to Proceed pursuant to this Subparagraph.

ADD THE FOLLOWING AS A NEW SECOND SENTENCE TO PARAGRAPH 8.3.1:

The Contractor acknowledges that the coronavirus (COVID-19) pandemic has impacted businesses across the country.

ADD THE FOLLOWING TO THE END OF THE FIRST PARAGRAPH IN 8.3.4.2.3:

The Parties agree that the weather station applicable to this Project shall be the one located at [redacted].

ADD THE FOLLOWING TO PARAGRAPH 8.5.1:

8.5.1.1 Substantial Completion Liquidated Damages shall be the sum of One Thousand Dollars (\$1,000) per calendar day, and this amount shall be assessed in accordance with Subparagraph 8.5.1 of the General Conditions.

8.5.1.2 Final Completion Liquidated Damages shall be the sum of One Thousand Dollars (\$1,000) per calendar day, and this amount shall be assessed in accordance with Subparagraph 8.5.1 of the General Conditions.

ARTICLE 9 - PAYMENTS AND COMPLETION

ADD THE FOLLOWING TO PARAGRAPH 9.6:

9.6.3 Additional services and dispute resolution services by the Design Consultant shall be paid by the Contractor at the rate of Two Hundred Dollars (\$200.0) per hour.

ARTICLE 15 – DISPUTE RESOLUTION

ADD THE FOLLOWING NEW PARAGRAPH 15.6:

- 15.6 The Owner's Dispute Resolution Policy required by N.C.G.S. § 143-128(f1) is contained in Policy [\(www. .com\)](#). The Dispute Resolution Policy is also included in the bid and contract documents.

END OF SUPPLEMENTAL CONDITIONS

NOTE: THESE CONDITIONS SUPERCEDE ANY CONFLICTING CONDITIONS IN THE GENERAL CONDITIONS OR SUPPLEMENTARY CONDITIONS

SALES TAX

Itemized sales tax expenditures by the Contractor will be reimbursed to the Owner. BIDS MUST INCLUDE SALES TAX.

DELAYS / CLAIMS

Any contractor whose work is delayed for reasons beyond his control shall immediately notify the Architect as to the nature of the delay, the cause of the delay, and the immediate effect on the project, including cost effects. Verbal notification shall be followed with written notification to the Architect no later than 10 days following the delay; otherwise, no consideration for a claim will be given. For delays claimed by reason of weather, the Contractor shall be required to substantiate such claim by the submission of weather reports for the time period of the delay as well as national weather service reports for the project area for the last ten years, the average of which shall become the basis to determine the validity of such claim. Time extensions granted for reasons of weather or other reasons except as caused by the Owner, with exceptions and time limits for convenience of the Owner as indicated under Section 01011, do not entitle the Contractor to "extended overhead" or "lost profit" recovery.

Delays which do not affect activities on the Critical Path of the approved CPM Construction Schedule will not be considered reason to allow time extensions. Time extensions granted for reasons other than natural weather disasters do not entitle the Contractor to "lost profit" recovery. Time extensions granted for reasons other than natural weather disasters do not entitle the Contractor to "extended overhead" recovery.

A Recovery Schedule is to be generated and submitted when a critical path activity date, or Project Completion date is not in compliance with the original contract requirement.

CLEAN UP AND PROTECTION OF WORK

The Contractor shall replace any broken glass, remove stains, spots and dirt from decorated work, clean hardware, remove paint spots and smears from all surfaces, clean plumbing fixtures and wash all concrete, and clean and wax resilient tile floors and clean hard tile floors. The Contractor shall be responsible for leaving his work clean in all respects, and shall be responsible for protecting his work from damage by other parties.

CHANGES IN THE WORK

The cost or credit to the Owner resulting from a Change in the work shall be determined as follows:

1. Allowances for overhead and profit combined shall not exceed 15 percent of net cost except when the change involves a Subcontractor, in which case allowances shall not exceed 15 percent for the Subcontractor and 7-1/2 percent for the Prime Contractor.
2. The profit and overhead rates proposed by the Contractor for the initial Change in the Work shall not be changed or modified for the duration of the Contract, and shall apply equally for additive and / or deductive changes.
3. The term "net cost" as used herein shall mean the difference between all proper cost additions and deductions. The "cost" as used herein may include all items of material and labor, the use of power tools and equipment, and such items of cost as Workmen's Compensation Insurance, Social Security and Old Age Benefit, Performance Bond Adjustment and pro-rata charges for

foreman. The following items shall be considered as overhead: insurance other than mentioned above, supervision, superintendents, timekeepers, clerks, watchmen, small tools, incidental job burdens and general office expense, and all other items not included in "cost" as above defined.

4. Price requests for changes in the Work furnished to the Architect shall include individual costs for materials, labor, subcontractor work (if applicable), and profit and overhead unless otherwise noted.
5. Unit Prices listed on Bid Form of Proposal, Sitework Material allowances, and Form of Contract shall include all overhead and profit costs. Overhead and profit shall not be listed as a separate or added cost when unit prices and materials allowances are used or credited.

TIME

The Contractor shall fully complete the Work in accordance with the schedule of COMPLETION DATES which are DATES CERTAIN, with no time extensions granted for any reason other than delays caused by the Owner (see below).

WEATHER

Weather is by its nature not "normal", and rain fall varies from year to year. Weather delays are to be accommodated within the schedule as specified, however, "natural disasters", such as caused by severe hurricanes, are excepted. In making his bid, the bidder acknowledges that provisions to accelerate the schedule will be provided as required to meet the scheduled dates, to accommodate abnormal weather conditions, or other delays, except as caused by the Owner.

PROJECT PHASING (note: "Prime" contractor means "sub" contractor under a Single Prime contracting method)

1. The General Contractor is responsible as the project coordinator for all the Prime Contractors. It is the General Contractor's responsibility to schedule the work of all Contractors, to maintain daily reports to the Architect and the Owner regarding the status of activities of all Contractors, and to submit plans to the Architect and Owner for recovery of any scheduled activity by any Contractor, to the Owner and Architect, for review and immediate implementation.
2. Each Prime Contractor shall be required to coordinate their schedule of activities with the General Contractor, and, in submitting a bid, agree to execute a construction schedule in conformance with the required completion dates. All parts of this schedule will be binding on each Contractor, and it is agreed by all Contractors that liquidated damages will be withheld for any delays caused by them which affect the completion date directly or indirectly, in the sole opinion of the Architect, as further described and defined under the Contract for Construction.
3. All Contractors agree that maintaining the scheduled completion of individual activities is essential for the overall completion of the project schedule, and understand that many activities by other Contractors are dependent on timely completion of their own activities. As such, it is understood and agreed by all Contractors that liquidated damages will be withheld, at the time of delay, for any delays which impact the completion of activities by other Contractors and cause the schedule to be revised to a later completion date. For example, the Sitework Contractor must complete various aspects of sitework in a timely manner to allow the other Prime Contractors to store and stage materials on stoned parking areas, or that finish grading, seeding, mulching, and fertilizing operations shall be completed in a manner which will allow the other Prime Contractors to complete their exterior finish work on time, to provide the project with a completed, full stand of grass on the completion date and not afterwards. As an additional example, General Contractor shall schedule his work and make all provisions to allow the Mechanical Contractor to complete his work in a timely manner to meet his scheduled completion date, which is prior to the General Contractor's completion date, in order for the General Contractor to utilize the HVAC system for

conditioning of the building. The foregoing illustrative examples are not intended to imply a listing of issues possible but only to serve as examples.

4. It is understood by all bidders that they will cooperate with each other to formulate and agree on a construction schedule detailing all significant activities of the project within 30 days of award.

COMPLETION DATES (ALL DATES CERTAIN)

The Start Date for commencement of the project will be seven days from the date of Notice to Proceed.

1. 60 calendar days: General Contractor shall submit construction schedule to Owner reflecting required dates and confirm that all subcontractors and material suppliers are in agreement.
2. 480 calendar days: The General Contractor shall complete their own construction review list and provide written statement stating as such to the Architect for all work, including finish grading, seeding, fertilizing and mulching all areas disturbed by construction activities.
3. 540 calendar days: The General Contractor will confirm in writing to the Architect that they have completed the Architect's construction review list (liquidated damages incurred).
4. 600 calendar days: General Contractor shall complete any remaining construction review items issued by Architect's (additional liquidated damages incurred).

LIQUIDATED DAMAGES

For each day in excess of the number of days allowed to complete construction under 8.1.5, for each scheduled date, the Contractor shall pay to the Owner the sum of \$1000.00 as liquidated damages reasonably estimated in advance to cover the costs and/or losses incurred by the Owner by the failure of the Contractor to complete the Work of any Phase indicated in the time specified, such time being in the essence of this Contract and a material consideration thereof. Liquidated damages for days in excess of completion date shall be held as retainage from monthly payments by the Owner, and released from subsequent payments only if delay days are made up and no damages have been incurred by the Owner. The Architect shall be the sole judge as to the division of responsibility between the prime contractors, and shall apportion the amount of liquidated damages to be paid by each of them, according to delay caused by any or all of them. Issuance of a Certificate of Occupancy by any Building Official DOES NOT constitute Substantial Completion or completion of construction under this paragraph. Substantial Completion is defined as suitable for use, in the opinion of the Owner and the Architect.

ADDITIONAL LIQUIDATED DAMAGES

For each day in excess of sixty days beyond the date of Substantial Completion that any corrective or incomplete items remain to be done, for each scheduled date, the Contractor shall pay to the Owner the sum of \$1000.00 as liquidated damages reasonably estimated in advance to cover the costs and/or losses incurred by the Owner by the failure of the Contractor to complete such corrective work or incomplete items for any Phase listed, such time being in the essence of this Contract and a material consideration thereof.

OWNER'S RIGHT TO COMPLETE WORK TO MAINTAIN SCHEDULE

The Contractor agrees that if the Architect determines, at his sole discretion, that the Contractor has repeatedly or persistently failed or refused to implement such measures as will bring the progress of the Work into conformity with the Construction Schedule, then the Owner may contract with others or use the Owner's own forces to perform the Work to bring the progress into conformity with the Construction Schedule. The Contractor agrees that the Owner will be entitled to a set off for the cost thereof including,

but not limited to , actual costs, legal fees, and additional overhead costs, which will be charged against the Contract Sum due the Contractor.

COST INFORMATION FOR INSURANCE PURPOSES

During the course of the construction, the contractor will be required to provide written cost breakdowns for various parts of the work for insurance purposes.

PAY APPLICATIONS AND RETAINAGE

Contractor shall submit Applications for Payments to the Architect monthly for work completed and materials stored ending the twenty-fifth day of the month. Retainage shall be five percent (5%) of monthly estimates. The Architect may, at any time after fifty percent of the work has been completed, if he finds that satisfactory progress is being made and with written consent of Contractor's Surety, recommend to the Owner that retainage be reduced to two and one-half percent (2.5%) of monthly estimates.

Sales tax expenditures shall be substantiated with a certified statement by the Contractor and each of his Subcontractors individually showing total purchases of material from each separate vendor and total sales taxes paid each vendor. Certified statement must have the invoice number or numbers covered and inclusive dates of such invoices.

Materials used from Contractor's or Subcontractor's warehouse stock shall be shown in certified statement at warehouse stock prices and amount of tax paid.

The Contractor shall not be required to certify the Sub-Contractor's statements.

The Contractor and each of his Sub-Contractors shall also show purchases of materials from each separate vendor and the cost of same for which no sales tax has been paid.

When applicable, file a Form E-589CI, Affidavit Of Capital Improvement.

BUILDERS RISK INSURANCE

Contractor shall provide Builder's Risk Insurance, payable to the Contractor and Owner as their interest may appear upon the amount of the bid and upon all materials in or adjacent thereto which are to be made apart of the insured structure to 100% of the insurable value thereof covering fire, extended coverage, vandalism and Malicious mischief.

END OF SUPPLEMENTARY CONDITIONS

SUMMARY OF WORK

This project involves the furnishing of all labor, materials, and services necessary to complete the construction of the BEAUFORT PK-3 SCHOOL, Beaufort County Schools, North Carolina as shown by the drawings and as specified herein.

CONSTRUCTION SCHEDULE

Each Prime Contractor shall coordinate his work with the others to complete his work, on schedule, within the specified time allowed. Within thirty days of award of Contracts to the successful Bidders, the General Contractor will prepare, with the assistance of each Prime Contractor, a Master Construction Schedule, in both bar chart and critical path method form, which shall be signed by each Contractor and become a requirement and part of the Contract Documents.

The Schedule shall include work by Architect and Owner, as may be required by the contractor (i.e. Critical shop drawing review, color selection, inspections, etc.).

The Master Schedule shall be created in electronic computer form using an industry-recognized "Critical Path Method" software program, and continuously maintained for the benefit and use of all Contractors and the Owner/Architect. The General Contractor shall submit to all parties, at each monthly meeting, printed reports, generated from the computer program file, indicating the current status of all project activities, including those of the other Contractors. A Recovery Schedule will be generated and submitted when a critical path activity date, or Project Completion date is not in compliance with the original contract requirement.

CONTRACTS

Contracts will be executed for each Prime Contractor on AIA Document A101, Standard Form of Agreement Between Owner and Contractor, as amended herein.

PAYMENTS

Payments to the Contractor will be made on the basis of ninety-five percent (95%) of monthly estimates approved by the Architect.

Bids shall include North Carolina sales and Use Tax or local sales and use tax. The Owner shall be entitled to reimbursement of taxes paid by Contractor on basis shown separately on monthly request for payment. At the time of delivery of the periodic monthly estimate and request for progress payments, the Contractor shall attach to such requests a statement which shall show the amount of sales tax paid by the Contractor upon purchases of building materials during the period covered by the progress payment request. A sworn statement by the Contractor shall be attached stating that the property upon which such sales taxes were paid was or will be used in the performance of the contract. Sales tax on purchases or rental of tools and equipment is taxable to the Contractor and shall not be included in the sworn statement. When applicable, file a Form E-589CI, Affidavit Of Capital Improvement. Refer to Section 01011, Supplementary Conditions, subparagraph 9.3.4 for additional requirements.

CONSTRUCTION PROCEDURES

The following Construction Procedures are to be implemented for this project:

1. The General Contractor shall be the Project Coordinator, and as such shall schedule and manage the entire work. Notify the Architect immediately upon any conflict with separate Prime Contractors.
2. The General Contractor shall coordinate with all Prime Contractors to prepare and submit to the Architect within two weeks following the date of the Notice to Proceed his proposed Progress

Schedule for completing the Project in the specified time. Include critical shop drawing reviews, inspections, or other work to be scheduled with Architect or Engineer.

3. Approved Schedule shall be distributed to all other Prime Contractors by the General Contractor. Also, post copy in Contractor's field office. General Contractor shall keep other contractors, including his subcontractors, informed of his planned and actual progress, so that the Project Schedule can be maintained.
4. All other prime and sub-contractors shall organize their work to conform to this Schedule and see that all phases of the work progress as smoothly and efficiently as possible.
5. The General Contractor will coordinate the location of tool sheds and storage areas for all contractors within the limits of the site area designated or approved by the Owner.
6. All Contractors shall submit within twenty (20) days from the date of the Notice to Proceed a complete list of all subcontractors and material suppliers (including addresses), that they propose to use on this Project for Architect's and Engineer's approval.
7. All Contractors are requested to furnish the Architect with the name of their project manager, safety manager, and job foreman or superintendent who will be in charge of the work. These men will not be changed during the course of construction without prior notice to the Architect. Furnish Architect and Owner with name and home telephone number of job superintendent and project manager for emergency contact.
8. Architect will hold monthly meetings at the project site on a day and time to be determined. Each Contractor shall have his job superintendent and project manager present. The purpose of these meetings is to evaluate progress, resolve problems, and in general to help expedite construction. Meeting representatives must have authority to act on behalf of the Contractor.
9. See Specifications, Division 1, General Requirements, for information relative to the following:
 - a. Schedules and Reports
 - b. Samples and Shop Drawings
 - c. LEED Requirements (THIS IS NOT A LEED PROJECT)
 - d. Temporary Facilities and Controls
 - e. Cleaning Up
 - f. Project Close Out
10. To expedite handling paperwork, the following procedures shall be used:
 - a. Shop drawings and submittals shall be submitted electronically individually via e-mail, in non-editable format PDFs, each with its own transmittal. Electronic submittals e-mail subject line will contain the project name, specification number, and product name. Each submittal will bear the contractor's review stamps and a statement of deviations.
 - b. Each Contractor shall submit to the Architect a cost breakdown of his contract on standard AIA form. Breakdown shall show labor and material. Upon approval by Architect and Engineer, this breakdown shall be used for progress payments.
 - c. Contractor's payment period shall be from the twenty-fifth day of the month to the twenty-fifth day of the following month. Contractor shall forward to the Architect by the first of the following month his Application for Payment in PDF format, submitted

- electronically, with ink professional seals. Owner will make payments by the fifteenth of the month. Professional seals shall be ink stamped, not embossed.
- d. Sales tax expenditures for each pay period shall be substantiated with an attached certified statement by the Contractor and each of his Subcontractors individually showing total purchases of material from each separate vendor and total sales taxes paid each vendor for the applicable period.
 - e. Payment for material stored on site will be approved upon verification of material and quantity. Payment will also be approved if material is stored in a bonded warehouse approved by the Architect and Owner and insured for its full value. Include insurance certificates and certificates verifying storage in bonded warehouse with Application for Payment of such materials.
 - f. Submit copy of Building Permit prior to or with submission of first Pay Application. Payments will be withheld until permit copy is submitted.
11. All materials and submittal data must be approved before Contractor proceeds with installing such items in the Project. All materials requiring color selection shall be submitted together. Contractor shall confirm in writing that color samples provided are current and available to select from. An incomplete color schedule will not be issued. All material samples must be submitted in order to make a complete, coordinated schedule.
 12. Materials and compaction testing company shall be selected by the Owner. The Architect will notify the Contractor of the company and of the specific testing to be done. Based on these instructions, the Contractor will be responsible for notifying the testing company of individual tests to be made.
 13. The Contractor shall issue daily electronic update reports, in PDF format, via e-mail, with descriptions of day's work performed, 3 photos minimum, weather conditions, parties on site with manpower counts, and equipment on site.
 14. Notify Architect, Structural Engineer, and Testing Laboratory twenty-four (24) hours prior to pouring footings. Pours shall always be the maximum that can be properly handled in a day.
 15. Inspection Reports from Architect or Engineers pointing up defective or unacceptable work shall be corrected immediately. Failure to do so will be cause to withhold monthly progress payments.
 16. Each Separate Prime Contractor shall be responsible for removing his own waste material and job debris from the all construction areas and the site, fully coordinated with requirements of the Construction Waste Management Plan (CWMP). This shall be done continually. Failure to keep job site clean and safe for maximum working efficiency will be cause to withhold monthly progress payments. Failure to comply with the Construction Waste Management Plan (CWMP) will be cause to withhold monthly progress payments.
 17. Construction workers will be properly dressed at all times on the site (shirts, shoes, etc.), and the use of foul language, vulgar or lewd gestures, or any other conduct deemed inappropriate by the Owner will be cause for immediate dismissal.
 18. Working Schedule: Working hours shall be coordinated among all Prime Contractors. Advise Owner and Architect.
 19. Claims: Follow General Conditions, as amended, for any claims for additional money or time. Claim must be made at time of discovery, time limits in accordance with these Conditions.
 20. Final Inspection of Projects: It is the Contractor's responsibility to notify the Architect that the project is complete and to submit a list of discrepancies to be corrected. Following such

notification, the Architect shall make a preliminary review of the project to verify completion. From the preliminary review, the Architect shall prepare a punch list of discrepancies for the Contractor. Upon notification by the Contractor that the discrepancies have been rectified, the Architect shall schedule a formal final inspection with the Owner.

21. Record Drawings: One (1) complete set of working drawings will be maintained on the job site by the General Contractor. If any changes or deviations from these drawings are made by any Contractor, such Contractor shall indicate the change on the drawings using colored pencils or ink.
22. Safety Regulations: All Contractors shall abide by current OSHA Regulations at all times. Be advised that the Owner is obligated by these Regulations to report any known violations to OSHA.
23. Smoking is prohibited and not allowed on the construction site property.

DRAWINGS AND SPECIFICATIONS

The following principles shall govern the settlement of disputes which may arise over discrepancies in the contract documents.

1. As between written figures given on drawings and the scale measurements, the figures shall govern.
2. As between large-scale drawings, and small scale drawings, the larger scale drawings shall govern. Discrepancies noted shall be reported to the Architect before commencing work.
3. Where more than one item or procedure is specified or indicated, the Contractor shall provide the item of greatest expense or most stringent procedure.

Titles to divisions and paragraphs in the contract documents are introduced merely for convenience and shall not be taken as a correct or complete segregation of the several units of materials and labor. The Contractor shall see that each subcontractor is familiar with the entire work under this contract to the extent that it affects his portion of the work, as no responsibility is assumed by the Architect for omissions or duplications by the Contractor or his subcontractors due to real or alleged error in arrangement of material in these documents.

The plans and specifications are both a part of this contract and shall be considered cooperative. Any work called for by the plans and not hereinafter specified or vice versa, shall be executed by the Contractor as if specifically mentioned in both.

The drawings and specifications are to be used for this building only and are the property of the Architect; they are to be returned to him before the final certificates are given.

After award of Contract, drawings and specifications shall be obtained and /or downloaded by the General Contractor from the Hite Associates website, www.hiteassoc.com. Additional drawings and / or specifications may be purchased by contacting Speedyblue Reprographics at (252) 758-1616, print@speedyblue.com.

INTENT OF DRAWINGS

In making a Proposal, the Contractor acknowledges that the drawings are diagrammatic in nature, and agrees to provide complete and finished construction assemblies to comply with the Architect's intent and pertinent Building Codes, whether all parts or components of such assemblies are shown or not (for example, doors or frames shown on plan drawings but not scheduled or detailed otherwise shall be

furnished, consistent with other doors or frames of type and material as would be reasonably inferable, complete with hardware).

For renovations and additions, the plans and specifications are intended to convey the broad scope of work that is to be included in the demolition scope and/or renovations scope of existing areas in the contract, they do not show every item or detail to be installed or removed. Provide complete and finished construction assemblies.

Bidders and their subcontractors must visit the site prior to bid to verify all existing conditions in areas to be renovated, including equipment platforms, to ascertain items to be removed or relocated to perform the work as shown and specified, and to provide complete assemblies. When available, existing building drawings are to be reviewed for concealed conditions. No allowance will be made for claims for additional cost or time based on conditions that are accessible for inspection.

STANDARD OF QUALITY, CONTRACT DEFINITION

The Standard of quality for all work shall be first class in all respects, in the opinion of the Project Architect and Project Engineer. In submitting a Bid, the Contractor agrees to abide by this Standard, and no other. Any work considered less than first class by the Architect/Engineer shall be corrected or removed and replaced as directed.

PROJECT MANAGER AND SUPERINTENDENTS, APPROVAL OF PERSONNEL

The Contractor shall provide resumes of proposed Project Manager and Superintendents to Owner, through Architect, for review and approval prior to assignment. Contractor shall submit only those candidates with a minimum of five years experience in the respective capacities proposed, with projects of similar size and scope.

FIELD SUPERVISION REQUIREMENTS

The Contractor is required to provide a full time Field Superintendent to supervise the work of their Contract and to be present, in the field, and not in a field office, at all times work is being performed by that Contractor or his Subcontractors, for the express purpose of providing continuous control of the quality and correctness of construction. In addition, the Contractor's Field Superintendent is required to provide general supervision and coordination of the work of all other Prime Contractors. This person is required to be equipped with a mobile telephone at all times. The Contractor shall issue daily electronic update reports, in PDF format, via e-mail, with descriptions of day's work performed, 3 photos minimum, weather conditions, parties on site with manpower counts, and equipment on site.

FIRE RATED CONSTRUCTION ASSEMBLIES

Where U.L., F.M., W.H.I., or other independent testing agency fire rated construction assemblies are referenced on the drawings, it shall be the Contractor's responsibility to meet the specific requirements of the assembly, as defined by State and Local Building Authorities.

MEASUREMENTS AND DIMENSIONS

Before ordering material or doing work which is dependent for proper size or installation upon coordination with building conditions, the Contractor shall verify all dimensions by taking measurements at the building and shall be responsible for the correctness of same. No consideration will be given to any claim based on differences between the actual dimensions and those indicated on the drawings. Any discrepancies between the drawings and/or the specifications and the existing conditions shall be referred to the Architect for adjustment before any work affected thereby is begun.

TOLERANCES

Unless otherwise specified, the maximum acceptable variation from plumb and level of any wall, floor, ceiling, roof, or constructed surface shall be at the following rates:

- Floors: Flatness of F25 and Levelness of F20. Reference Section 03250, Flatness and Levelness.
- Ceilings: 1/4" in ten feet maximum.
- Walls: 1/8" in ten feet maximum.
- Doors: 1/4" warp across surface maximum.
- Door Frames: 1/16" top to bottom maximum.
- Wood Joinery: Imperceptible by touch.
- Aluminum Storefront / Window System Joints: 1/32" maximum.
- Window / Door Frame edges to opening surfaces: 1/4" maximum.

Work which does not meet these tolerances will be rejected. Concrete slabs will be inspected immediately after finishing for correctness. Concrete work which does not meet the prescribed tolerances will be rejected and immediately removed.

SAMPLES AND SHOP DRAWINGS

Each Contractor shall submit such samples of materials and examples of workmanship as are requested by the Architect to show quality and kind of material and work he proposes to deliver or perform in executing his contract.

Shop drawings and submittals shall be submitted electronically, in non-editable format PDFs, submitted via e-mail. Electronic submittals e-mail subject line will contain the project name, specification number, and product name.

Coordinate LEED submittals with general submittal requirements. Refer to Section 01405 LEED Requirements.

Contractors shall make all submittals promptly after award of contract. Submittals requiring color selection shall be made no later than 60 days after award of contract. Contractor and manufacturer shall confirm in writing that color samples provided are up-to-date, current and can be provided.

All material requiring color selection shall be submitted for review before any colors are selected. The Contractor shall allow 45 days after all submittals are made and all color samples received for the Owner to make selections, and schedule his submittals accordingly.

TEMPORARY FACILITIES

This section covers the furnishing of all appliances, labor, materials, tools, transportation and services required to perform and complete all preliminary work and temporary construction required for the building and site as indicated.

Storage - Each Contractor shall provide such temporary structures as are required for the protection of persons and property. On barricades where necessary, lights shall be maintained at night.

Field Office - General Contractor shall provide and maintain a full time field office construction trailer at the site, equipped with heat, lights, plan desks and telephones. Office shall be sufficient size for use by this Contractor and for on-site meetings with a separate office provided specifically for the Architect's Representatives.

Scaffolds, Tolls, etc. - Each Contractor shall erect and provide all necessary platforms and scaffolds of ample strength required for the handling of materials and equipment such as ladders, horses, poles, planks, ropes, wedges, centers, etc.

Pumping - Each Contractor shall keep all excavations free from water by pumping or other adequate means and shall do any and all shoring or other work necessary to keep excavations in good and safe condition. Provide trenching as required to conduct surface water away from the building.

Temporary Heat / Humidity Control - The General Contractor shall provide at his own expense temporary heat and humidity control to protect all work and materials against injury from dampness and cold and to dry out the building. Control shall be established prior to installation of ceiling tile, millwork, or other finishes. The General Contractor shall have the use of the building mechanical systems for this purpose, provided that the building is, in the opinion of the Architect, sufficiently clean and secure. The General Contractor shall take precautions as recommended and monitored by the Mechanical Contractor for proper filtration and to keep all parts of the mechanical system free from dust or contamination from construction activities. The General Contractor shall be responsible for any cleaning, repairs or replacement of the building mechanical system or parts thereof as a result of contamination or other damage caused by misuse. Refer to specifications for specific temperature requirements relative to various parts of the Work.

Temporary and Permanent Utilities - The General Contractor shall furnish at his own expense all water, electrical power and lighting, and other utilities necessary for construction purposes by all Prime Contractors. Temporary electric service panels shall be provided and installed by the Electrical Contractor as directed by the Architect.

GFI (Ground Fault Interruption) Protection - GFI Protection of temporary power panels is the responsibility of the Electrical Contractor. GFI Protection of electrical outlets served by permanent building power panels is the responsibility of the Contractor using the power until a Certificate of Occupancy is issued for the building.

Staging: The location of trailers and material storage areas shall be approved by the Architect. Each Prime Contractor will be responsible for repair and testing of the paving base if damaged by his staging activities.

Working Hours: Single or separate prime contractors may set their own working hours, provided, however, that the Project is under supervision by the General Contractor at all times work is being performed.

Sanitation: The General Contractor shall provide and maintain temporary toilets as necessary for use of all workmen. Locate toilets where directed, keep in sanitary condition, and comply with the requirements of the local public health authority.

OSHA

It shall be the responsibility of all contractors to conform to the latest edition of Safety Standards for construction by "OSHA".

CUTTING AND PATCHING / REPLACE

All cutting and patching throughout Project shall be done by the trade requiring the cut. Patching of work or areas affected by cutting, digging and fitting shall be done by mechanics skilled in the applicable trades and shall match surrounding or adjoining similar work. If the quality of the cutting and patching work is

not first class and, in the opinion of the Architect, not acceptable, the Contractor will be required to have this work done by the General Contractor, who will be reimbursed for the cost thereof.

Where documents indicate the terms "replace" or "replacing" of any item or system, the items or system called out to be replaced shall be removed in their entirety complete, by the trade performing the replacement.

CLEANING UP

Each Prime Contractor shall be responsible for keeping the project clean and free of hazardous working conditions. Remove scrap or surplus materials and keep stored materials in a neat and orderly fashion, minimum once weekly.

The General Contractor shall advise all subcontractors and separate prime contractors of their responsibility to keep their part of the project clear and free of accumulated debris.

After completion of Utility Platforms and Main Boiler and Electrical Room construction by all contractors, the General Contractor shall provide a complete vacuuming and wipe down of all mechanical and electrical equipment, including ductwork. The General Contractor shall then provide two coats of clear polyurethane floor sealer as specified to these spaces, after approval of the condition of each space by the Architect.

At the completion of work, the entire project shall be left clean and ready for occupancy. All finished surfaces shall be cleaned, polished, waxed and left in first class condition.

CONSTRUCTION WASTE MANAGEMENT: WASTE AND RECYCLING

The General Contractor shall be responsible for developing and implementing a Construction Waste Management Plan (CWMP) that identifies the materials to be diverted from disposal and their quantities by weight in order to divert a minimum of 75% of all construction and demolition debris. The GC shall submit monthly progress reports indicating quantities disposed and quantities diverted along with each Payment Application. The GC shall also be responsible for providing separate recycling collection containers for disposal and recycling of non hazardous construction and demolition waste. All containers must be clearly labeled with a list of acceptable and unacceptable materials that meet the requirements of the recovery facility or recycling processor, to which the materials shall be hauled. The General Contractor shall provide on site instruction of appropriate separation, handling, and recycling, and return methods to be used by all contractors. These containers shall be maintained on a regular schedule by either the GC or a GC contracted service. If the contracted service provides off-site sorting services, then waste may be commingled on site per the contracted services specifications. If commingling on site is not permitted, then containers are to be provided for the following materials:

1. Concrete waste
2. Brick and CMU (shall be recycled)
3. Wood and Wood Products
4. Cardboard (shall be recycled)
5. Steel and Metals (shall be recycled)

OWNER SYSTEM TRAINING SESSIONS

Each Contractor shall have factory trained and certified product representatives provide equipment and system training sessions for the Owner for each product and system. Sufficient training shall be provided to the extent that each Owner attendee is fully versed on the product and/or system and can be a designated "trained" participant, and that each participant can demonstrate the ability to operate each product and system in total variety of operations. Provide multiple training sessions if such is required to be certified as fully trained personnel. An Owner Training Certification is to be provided. Submit an affidavit that each required Owner training session has been performed. Submitted affidavit to include

sign-up log of attendees/trainees and description of system or product, cross referenced to the specific contract document.

PROJECT CLOSEOUT

Prior to issuance of a Certificate of Final Payment, unless otherwise noted, each Prime Contractor will be required to deliver to the Architect the following items, in encrypted electronic PDF format, indexed with a hyperlinked Table of Contents. All professional seals shall be stamps, not embossed. Files to be submitted on an electronic storage device. All warranties requiring signatures for execution, shall be submitted in paper format.

1. Certificate Of Occupancy issued by the jurisdiction having authority.
2. Fully executed final Change Order, reconciling all project allowances.
3. Submit five copies of Final Application for Payment, AIA Documents and Final Sales Tax Report collated and stapled together.
4. AIA Document G 706/Contractors Affidavit of Payment of Debts and Claims, and AIA Document G 706 A/Contractors Affidavit of Release of Liens, properly executed, notarized, with no exceptions.
5. Consent of Surety to Final Payment.
6. Certificate of Compliance. Each Prime Contractor shall furnish the Architect a certificate, duly notarized, stating that he has constructed his part of the work of the project in complete compliance with the Drawings and Specifications.
7. Each Prime Contractor shall furnish to the Owner through the Architect a certificate, duly notarized, stating that "no hazardous materials, including lead, asbestos, or PCBs, have been used in the work of the Contract".
8. Each Prime Contractor shall furnish to the Owner through the Architect in triplicate, duly notarized, an unconditional Warranty to guarantee his work free from defects in materials and workmanship for a period of one year following Substantial Completion.
9. Operations and Maintenance Manuals indexed, shall be submitted in electronic format with items and sections hyperlinked to the O&M's Table of Contents. Provide paper copies of product warranties.
10. As-Built drawings. Each prime contractor shall deliver to Architect one complete set of as-built drawings. Changes in the work shall be marked in red on a new set of drawings.
11. Transmittal of keys to Principal, acknowledgement signed by Principal, and Finish Hardware Bitting List.
12. Final Color Finishes Schedule.
13. Owner Training Certification: Submit affidavit that each required Owner training session has been performed. Submitted affidavit to include sign-up log of attendees and description of system or product cross referenced to the specific contract document.
14. Process and deliver to the Architect all product guarantees and warranties, materials and testing certificates, etc., as required by various sections within these specifications and by various agencies having jurisdiction over the Work, indexed.

Do not make separate submittals of the above. Incomplete submittals will be returned to the Contractor.

END OF SECTION

Contractor is required to use the provided "Contractor Sales Tax Report Of NC State And Local Taxes Paid". Report shall be provided for each pay period, as an attachment to the contractor's Payment Application.

GO TO NEXT PAGE

1. **CONFLICT OF GRADE:** It is intended that the water mains be installed with a minimum of 36"inch cover, but the contractor is notified that he will be required to install the water mains with more than 36-inch cover as required in order to avoid conflicts.
2. **THRUST RESTRAINT:** Concrete blocking shall be installed as required at all tees, bends, etc., for all pipes unless otherwise directed. No separate payment shall be made for thrust restraint.
3. **CONNECTION TO AHJ (Authority Having Jurisdiction) OWNED FACILITIES:** No connection to or alteration (including operation of valves, hydrants, etc.) of the AHJ (Authority Having Jurisdiction) facilities shall be performed without the AHJ specific approval. All pipe, valves, taps, fittings, etc. which could possibly contaminate the AHJ's facilities shall be thoroughly disinfected prior to their use. Excavations for such connections shall be kept completely dewatered and the utmost care exercised to avoid contamination of AHJ owned facilities.
4. **SALVAGE OF AHJ OWNED FACILITIES:** When project work results in removal of AHJ owned facilities and equipment, the Contractor shall be required to deliver those facilities or equipment undamaged to the AHJ's Operation Center, if requested to do so by AHJ.
5. **NOTIFYING UTILITIES COMPANIES:**
 - 5.1 In accordance with the Underground Damage Prevention Act, the Contractor shall, within a time frame of not less than 2 or no more than 10 working days prior to the start of any excavation within any public right of way or private easement areas owned by a utility company, notify each utility owner having underground utilities in the area to be excavated of the following information:
 1. Name, address, and telephone number of the person serving the notice.
 2. Name, address, and telephone number of the company that will be performing the excavation.
 3. Anticipated starting date of the excavation and duration.
 4. Type of excavation to be conducted.
 5. Location of excavation.
 6. Whether or not explosives will be used.
 7. Contractor shall notify NC One Call, Greensboro, N.C. at least 48 hours prior to commencing construction in order that existing utilities in the area may be flagged or staked. The toll-free number is 1-800-632-4949. This service will in no way relieve Contractor of his responsibility to protect and maintain all existing utilities in an operational manner. Utilities location by NC One Call is not valid after the expiration of a 10-day period beginning on the date of such location.
 - 5.2 **Responsibilities during Construction:** In addition to serving notice of intent to perform excavation, the Contractor shall:
 1. Plan the excavation to avoid damage and to minimize interference with underground utilities in and near the construction area to the best of his abilities;
 2. Maintain a clearance between an underground utility and the cutting edge or point of any mechanized equipment, taking into account the known limit of control of that cutting edge or point, as is reasonably required to avoid damage; and
 3. Provide support for the underground utilities in or near the construction area, including backfill, as may be reasonably required by the utility owner for the protection of the underground utilities.
 4. When excavation by the Contractor results in known damage to an underground utility, the Owner of the utility shall be notified immediately and the utility given a reasonable time in which to repair the damage before the Contractor proceeds with excavation in the immediate area of the damage.
 - 5.3 **Responsibility of Utility:** Once notified, each utility must, prior to the day designated by the

Contractor as the anticipated start date, provide the Contractor with the following information:

1. The location of the utility;
2. The location and description of all utility markers;
3. Any other information that would assist in locating the utility, including temporary markers when necessary.

- 5.4 **Failure to Respond:** If the utility fails to respond to the Contractor's notice or fails to properly locate its underground utilities, the Contractor is free to proceed with excavation. Neither the Contractor nor Owner is liable for damage to utilities if the Contractor exercises due care.

6. **CONSTRUCTION STAKE-OUT:**
The construction staking shall be performed by a Registered Land Surveyor at least twenty-four (24) hours and three hundred feet (300') in advance of construction and shall identify the party responsible for payment for same.

The staking will include waterline, valves and fire hydrant stakeout; sanitary sewer stakeout; water and sewer services; rough grade staking; curb and gutter staking; storm drainage structure staking.

7. **TRAFFIC CONTROL:** The Contractor shall be responsible for maintaining an approved traffic control plan during the course of this work. The traffic control plan implemented for this project shall be devised through a joint effort of the NCDOT and the Contractor immediately prior to construction. In all instances, however, the Contractor shall be required to furnish, place, and maintain all signs, barricades, cones, and other traffic handling devices necessary to implement the traffic control plan.

8. **PROJECT SCHEDULE:** The Contractor shall be required to furnish an anticipated schedule of work at the time of the pre-construction conference. In addition, the Contractor shall be required to furnish bi-weekly updates of the schedule of work.

9. **FINAL CLEAN-UP:** The Contractor shall clear all streets, curbs, gutters, driveways and other contract items of all dirt and debris before final inspection will be made. The Owner will not inspect the improved area until they are cleaned.

10. **USE OF A PORTION OF THE WORK:** Whenever, in the opinion of the Engineer, any portion of the work is completed, or is in an acceptable condition for use, it shall be used for the purpose intended. Such use shall not be held in any way as an acceptance of that portion of the work used, or as a waiver of any of the provisions of these specifications. Necessary repairs or renewals in any section of the work due to defective materials, defective workmanship, or natural causes, under the instructions of the Engineer shall be performed by the Contractor at no additional cost to the Owner.

11. **SPECIAL AREAS:** Special access to construction other than existing easements or rights-of-ways shall be the responsibility of the Contractor and he shall be liable for all special agreements.

12. **MOBILIZATION:** Shall be accomplished in accordance with Section 800 of the N.C. State Highway Specifications for Roads and Structures except that there will be no compensation for mobilization as a line item.

13. **TEMPORARY TOILETS:** Provide temporary toilet facilities for use of all workmen. Inure temporary toilet facilities comply with local and State sanitation laws and regulations. Use of existing facilities by Contractor is not permitted.

14. **DRAWINGS SHOWING CHANGES DURING CONSTRUCTION:** The Contractor shall maintain a set of plans and specifications marked "Construction Record Drawings". The Contractor shall keep a complete and up-to-date record in red pencil of any and all changes made during

construction. This set of Contract Documents shall be submitted to the Engineer and approved by him prior to the Engineer recommending final payment.

15. **PRECONSTRUCTION CONFERENCE**: Conference shall be held in the AHJ at a designated place, after acceptance of proposals. Engineer will notify Contractor of time and date of meeting.

Prior to commencing any water or sewer extension construction work, the Department Engineer shall be contacted to schedule a preconstruction conference. No construction shall occur until after the preconstruction conference is held.

16. **WORK IN NORTH CAROLINA RIGHT-OF-WAY**: A bond shall be posted with the State of North Carolina for ten percent (10%) of the cost of construction within the right-of-way. This bond shall be posted prior to commencement of work.

17. **NORMAL WORK HOURS**: Unless special written consent is issued by the AHJ, all construction shall be performed during the regular office hours of the AHJ, i.e. 8:00 a.m. to 5:00 p.m. After hours, holiday, or weekend work should include only such tasks that do not require observation by the AHJ's Representative. Under certain conditions, the AHJ may agree to provide construction observation after hours or on weekends and holidays. The Contractor shall bear the costs of provision of such construction observation.

18. **OPERATION OF EXISTING FACILITIES**:

1. The Contractor performing water or sewer extension work shall contact the Department Engineer whenever operation of the AHJ's valves or hydrants is necessary to request scheduling of such operation. The AHJ shall require the Contractor to estimate the length of time service will be interrupted and the number of customers to be affected.

2. Facilities and equipment belonging to the AHJ may not be operated or adjusted without the express permission of the AHJ's Representative. In the case of any emergency, the Contractor shall be allowed to take such steps with valves and hydrants as necessary for the protection of life and property.

3. Valves which control networks not yet accepted but which are connected to the existing system shall be considered system valves. Valves within a network not yet accepted and which do not control the flow of water between new and existing systems are not considered system valves and do not require permission to operate.

4. Notification to the AHJ must be made by the Contractor upon breakage of any AHJ maintained water or sewer line or appurtenance thereof. Repair of the AHJ's facilities shall be made by the Contractor upon approval of the Department Engineer. Any repairs made with AHJ forces will be billed to the contractor at cost.

5. Where interruption of service is required, the AHJ shall be notified to request approval and subsequent scheduling of such interruption. The AHJ shall notify the affected customers should the interruption be approved.

19. **Project Close-out**:

A.. Pre-final Inspection: upon the completion of construction, the Contractor or Developer shall contact the AHJ to schedule a pre-final inspection. A pre-final inspection will not be scheduled until the following requirements are met:

- a. The work shall be in accordance with the requirements of the AHJ.
- b. A copy of the final estimate has been submitted and approved by the AHJ.
- c. The easements and dedicated property required for the work by this Manual have been obtained and are recorded at the Register of Deeds.

- d. The As- built drawings for the work have received the approval of the Department Engineer.
- e. All fees applicable to the project have been received by the AHJ.
- f. When a project includes sewer system extension(s), the AHJ has received certification by a Professional Engineer stating that the sewer system installation conforms with the requirements of the approved Contract Documents as required by Section .0219 of the DEHNR regulations (G.S. 143-215.1).
- g. When a project includes water system extension(s), the AHJ has received certification by a Professional Engineer stating that the water system installation conforms with the requirements of the approved Contract Documents as required by Section .0903 of the NCDHS regulations (G.S. 130A-315; 130A-317).

At the scheduled pre-final inspection, the Department Engineer shall perform a visual inspection in the presence of the representatives of the Contractor and the Engineer. The Engineer or his representative shall prepare a detailed punch list of any deficiencies discovered and provide copies to the Developer, Contractor, and the AHJ. Any defective items noted shall be corrected prior to acceptance.

B. Final Inspection: upon completion of the items on the punch list, the Contractor or Developer shall contact the AHJ to schedule the final inspection. Any remaining defective items shall be noted and corrected prior to acceptance. No service shall be provided prior to project acceptance.

*****END OF SECTION*****

GENERAL

The Base Bid constitutes the primary choice of the Owner with respect to the pertinent specifications for construction, materials, equipment and supplies. The Owner reserves the right to accept or reject any or all Alternates, in any combination with the Base Bid, in accordance with the general provisions of the Contract for Construction.

See Form of Proposal for complete description of Alternates.

END OF SECTION

GENERAL

CASH ALLOWANCES:

The Contractor shall include a CASH ALLOWANCE in his bid of \$1,595,000 to include labor, tax, and freight. The Owner reserves the right to bid the work or select subcontractors, and to credit the balance of the allowance at the completion of the Contract. Unit Prices listed on Bid Form of Proposal, Sitework Material allowances, and Form of Contract include all costs, including overhead and profit costs, and shall not be listed as a separate cost when unit prices and materials allowance materials are used or credited.

The work and items covered in the CASH ALLOWANCE are indicated in the plans and specifications, and include:

- Electric, sewer, water, and gas utility tap and impact fees (75)
- Testing and Special Inspections (175)
- BDA Emergency Responders Radio Coverage system, testing and equipment as required (100)
- Project sign and permanent signage inside and out (70)
- Music Room Acoustical Panels (20)
- Video monitors or projection systems with hardware and brackets, technology equipment such as racks, switches, and UPSs (395)
- Building equipment such as storage room shelving (10)
- Hazardous Material Abatement (turnkey design and removal) (100)
- Playground equipment (150)
- Other items or work directed by the Owner (500)

Equipment or items which are specified and not noted to be a part of an ALLOWANCE are to be priced and included in bid separately.

BUILDING PERMITS and all other permit costs shall be determined by Bidders and provided for in Bids.

MATERIAL ALLOWANCES:

1. Mass undercut for building pads and pavement areas: General Contractor shall provide in his bid 2,000 cubic yards of mass undercut, disposal off site, and select or structural off-site borrow backfill, compacted in place, as directed by the Geotechnical Engineer. Specified stripping of site as indicated in Geotechnical Report and fill as indicated by finished construction grades is NOT a part of this allowance. Geotechnical Report recommendations for removal of wood/rootmat material subgrade layers, as a component of stripping and site clearing operations, is NOT a part of this allowance.
2. Foundation undercut: General Contractor shall provide in his bid 200 cubic yards of localized undercut installed for building foundations and floor slabs, disposal off site, with backfill of #57 or #67 washed stone, in addition to the specific requirements on the Structural Plans.

NOTE: THESE MATERIAL ALLOWANCES WILL BE MEASURED AND MONITORED BY THE OWNER'S TESTING AGENCY. AMOUNTS NOT USED WILL BE CREDITED BACK TO THE OWNER AT THE UNIT PRICE INDICATED ON FORM OF PROPOSAL. AMOUNTS USED IN EXCESS OF THESE ALLOWANCES WILL BE CHARGED TO THE OWNER AT THE SAME UNIT PRICES.

END OF SECTION

The recommendations of the Geotechnical Subsurface Report shall be and are the requirements of the Work, AS MODIFIED HEREIN.

All bidders are advised to carefully review the soil conditions of the project site and the site itself, and shall take into account in their bid, conditions that will require weatherproofing of the building pad or areas outside the building pad, with stone or other materials to allow construction to continue in wet weather, and to provide off site select backfill for trenches where natural soils may not reach specified compaction.

Eastern Elementary

Geotechnical Engineering Report

November 17, 2023 | Terracon Project No. 72235092

Prepared for:

Beaufort County Schools
1010 Pennsylvania Ave
Washington, NC 27889

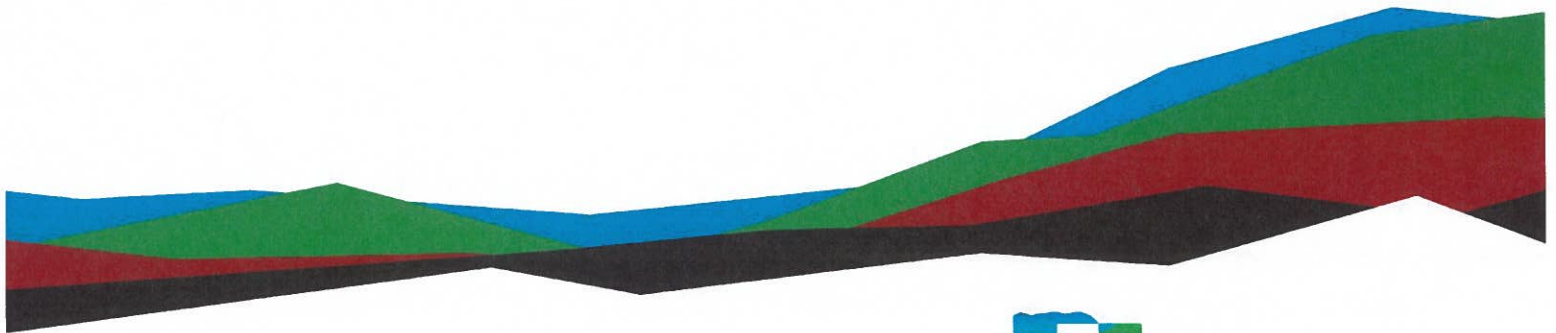

Nationwide
[Terracon.com](https://www.terracon.com)

- Facilities
- Environmental
- Geotechnical
- Materials



314 Beacon Drive
Winterville, NC 28590
P (252) 353-1600
North Carolina Registered, F-0869
Terracon.com

November 17, 2023

Beaufort County Schools
1010 Pennsylvania Ave
Washington, NC 27889 27 804

Attn: Jamie Stokes / Maintenance Director BCS
P: 252-946-3735
E: jstokes@beaufort.k12.nc.us

Re: Geotechnical Engineering Report
Eastern Elementary
947 Hudnell Street
Washington, North Carolina
Terracon Project No. 72235092

Dear Mr. Stokes:

We have completed the scope of Geotechnical Engineering services for the above referenced project in general accordance with Terracon Proposal No. P72235082 dated September 8, 2023. This report presents the findings of the subsurface exploration and provides geotechnical recommendations concerning earthwork and the design and construction of foundations, floor slabs, and pavements for the proposed project.

We appreciate the opportunity to be of service to you on this project. If you have any questions concerning this report or if we may be of further service, please contact us.

Sincerely,



Andrew J. Gliniak, P.E.
Project Engineer
Registered, NC 042183

Andrew A. Nash, P.E.
GEO Department Manager - Raleigh

Table of Contents

Report Summary	i
Introduction.....	1
Project Description.....	1
Site Conditions	3
Geotechnical Characterization	3
Geology.....	4
Seismic Site Class.....	5
Liquefaction	5
Geotechnical Overview	5
Earthwork	6
Shallow Foundations	13
Floor Slabs	15
Lateral Earth Pressures	17
Pavements	19
General Comments	23

Figures

GeoModel

Attachments

- Exploration and Testing Procedures**
- Photography Log**
- Site Location and Exploration Plans**
- Exploration and Laboratory Results**
- Supporting Information**

Note: This report was originally delivered in a web-based format. **Blue Bold** text in the report indicates a referenced section heading. The PDF version also includes hyperlinks which direct the reader to that section and clicking on the  logo will bring you back to this page. For more interactive features, please view your project online at client.terracon.com.

Refer to each individual Attachment for a listing of contents.

Report Summary

Topic ¹	Overview Statement ²
Project Description	The project includes a 135,000 square foot single-story school building. The building will have four wings around the center area being administration, cafeteria, and gym with associated driveways and parking.
Geotechnical Characterization	The exploration encountered existing fill, very loose to medium dense sand and medium stiff to stiff clay underlain by a deeper deposit of limestone. Groundwater is anticipated at depths ranging from 5 to 11 feet beneath existing site grades (bgs) in the building footprint and 2 to 5 feet in the pavement areas.
Earthwork	Low ground pressure/tracked equipment should be anticipated for low lying areas of the site during site preparation. The existing fill in the borings appeared suitable to remain in-place after the recommended earthwork. Our recommendations include limiting cut depths, vibratory rolling the subgrade and remediation of soils that are not improved during earthwork. Isolated foundation undercut of relatively softer/looser soils such as encountered at Boring locations B-2, B-8, B-10, and B-13 could be required to depths of 4 feet bgs. Further details are provided in Earthwork . Vertical construction on proposed grades greater than 4 feet should be delayed until settlement sufficiently diminishes.
Shallow Foundations	With subgrade prepared as noted in Earthwork . Allowable bearing pressure = 1,500 psf Expected settlements: < 1-inch total, < 1/2-inch differential
Pavements	With subgrade prepared as noted in Earthwork . Concrete: <ul style="list-style-type: none"> ■ 5 inches Portland Cement Concrete (PCC) over 4 inches ABC in Light Duty and Medium Duty areas ■ 7 inches PCC over 4 inches ABC in Heavy Duty areas Asphalt: <ul style="list-style-type: none"> ■ 3 inches Asphaltic Concrete (AC) over 6 inches ABC in Light Duty areas ■ 4 inches AC over 8 inches ABC in Medium Duty areas
General Comments	This section contains important information about the limitations of this geotechnical engineering report.

1. If the reader is reviewing this report as a pdf, the topics above can be used to access the appropriate section of the report by simply clicking on the topic itself.
2. This summary is for convenience only. It should be used in conjunction with the entire report for design purposes.

Introduction

This report presents the results of our subsurface exploration and Geotechnical Engineering services performed for the proposed school to be located along 947 Hudnell Street in Washington, North Carolina. The purpose of these services was to provide information and geotechnical engineering recommendations relative to:

- Subsurface soil conditions
- Groundwater conditions
- Seismic site classification
- Site preparation and earthwork
- Dewatering considerations
- Foundation design and construction
- Floor slab design and construction
- Lateral earth pressure
- Pavement design and construction

The geotechnical engineering Scope of Services for this project included the advancement of borings, laboratory testing, engineering analysis, and preparation of this report.

Drawings showing the site and test locations are shown in the [Site Location](#) and [Exploration Plan](#) sections, respectively. The results of the laboratory testing performed on soil samples obtained from the site during our field exploration are included on the boring logs and as separate graphs in the [Exploration and Laboratory Results](#) section.

Project Description

Our final understanding of the project conditions is as follows:

Item	Description
Information Provided	Email communication with site plans provided on August 25, 2023.
Project Description	The project includes a 135,000 square foot single-story school building. The building will have four wings around the center area being administration, cafeteria, and gym. Two parking lots for buses and cars, and drive aisles will be associated with the project.

Item	Description
Building Construction	Steel frame Wood frame Slab-on-grade
Finished Floor Elevation	Unknown, assumed to match existing.
Maximum Loads	In the absence of structural loading information provided by the design team, we have assumed the following structural loads to estimate settlement at the site: <ul style="list-style-type: none"> ■ Columns: up to 150 kips ■ Walls: less than 3 kips per linear foot (klf) ■ Slabs: less than 100 pounds per square foot (psf)
Grading/Slopes	Approximately 4 feet of cut and 6 feet of fill is anticipated to develop final grade, excluding remedial grading requirements.
Below-Grade Structures	None.
Free-Standing Retaining Walls	Based on previous experience with the site and potential grading, retaining walls up to 6 feet high could be associated with the project.
Pavements	We assume both rigid (concrete) and flexible (asphalt) pavement sections should be considered. Anticipated traffic is as follows: <ul style="list-style-type: none"> ■ Autos/light trucks: 1,000 vehicles per day ■ Buses: 60 per day ■ Light delivery and trash collection vehicles: 20 vehicles per week ■ Tractor-trailer trucks: <1 vehicle per week The pavement design period is 20 years.
Stormwater Management	Stormwater management information has not been proposed/requested at this time.
Building Code	2018 North Carolina State Building Code

Terracon should be notified if any of the above information is inconsistent with the planned construction, especially the grading information, as modifications to our recommendations may be necessary.

Site Conditions

The following description of site conditions is derived from our site visit in association with the field exploration and our review of publicly available geologic and topographic maps.

Item	Description
Parcel Information	The project is located south of the existing Eastern Elementary School at 947 Hudnell Street in Washington, North Carolina. See Site Location
Existing Improvements	Undeveloped grass field. A dirt road off Maple Street bisects a portion of the site. A former lighted soccer field was located on the southern portion of the site. Prior to the development of the school, public historic aerials dated 1962 from the NCDOT show what appears to be a residential development across the site.
Current Ground Cover	Grass, a few trees are located along Pennsylvania Avenue.
Existing Topography	Gently sloping to the southwest in elevation ranging from 16 feet to 6 feet MSL based on publicly available topography maps published by the USGS and Google Earth Pro™.

We also collected photographs at the time of our field exploration program. Representative photos are provided in our [Photography Log](#).

Geotechnical Characterization

Soil Profile

We have developed a general characterization of the subsurface conditions based upon our review of the subsurface exploration, laboratory data, geologic setting and our understanding of the project. This characterization, termed GeoModel, forms the basis of our geotechnical calculations and evaluation of the site. Conditions observed at each exploration point are indicated on the individual logs. The individual logs can be found in the [Exploration Results](#) and the GeoModel can be found in the [Figures](#) attachment of this report. Surficial materials are not included in the GeoModel.

As part of our analyses, we identified the following model layers within the subsurface profile. For a more detailed view of the model layer depths at each test location, refer to the [GeoModel](#). Surficial materials are not included in the GeoModel and CPT model layers do not delineate these materials.

Model Layer	Layer Name	General Description
1	Existing Fill	Sand, trace amounts of debris
2	Sand	Very loose to medium dense sand with variable amounts of silt and clay
3	Clay	Medium stiff to stiff clay with variable amounts of sand
4	Limestone	Limestone

We anticipate that the existing fill soil encountered in our exploration test locations was placed during the original development or prior development of the site and can contain debris from previous demolition. The existing fill material encountered was primarily sandy. Bulk samples collected during exploration in the upper 3 feet of soil included trace amounts of broken glass and nails at location B-P6. Based on N values of 4 to 13 within the fill soils, the material appears to have been placed in a variable manner, but we have no records indicating the degree of control implemented when the fill was placed.

Groundwater Conditions

Mud rotary drilling techniques were used which obscure groundwater measurements in SPT borings. Based on the measured water levels during exploration, cave in depths, and moisture condition of the soil samples, groundwater is anticipated at depths ranging from 5 feet to 11 feet beneath existing site grades (bgs) in the building footprint and 2 feet to 6 feet in the pavement areas on the west side of the site. Groundwater was not encountered/anticipated within 6 feet of bgs along the proposed pavements on the eastern side of the site.

Groundwater level fluctuations occur due to seasonal variations in the amount of rainfall, runoff and other factors not evident at the time the soundings were performed. Therefore, groundwater levels during construction or at other times in the life of the structure may be higher or lower than the levels indicated on the exploration logs. The possibility of groundwater level fluctuations should be considered when developing the design and construction plans for the project.

Geology

The project site is located in the Coastal Plain Physiographic Province. The Coastal Plain soils consist mainly of marine sediments that were deposited during successive periods of fluctuating sea level and moving shoreline. The soils include sands, silts, and clays with irregular deposits of shells, which are typical of those lain down in a shallow sloping sea bottom. Recent alluvial sands, silts, and clays are typically present near rivers and creeks.

According to USGS Mineral Resources On-Line Spatial Data based on the 1998 digital equivalent of the 1985 Geologic Map of North Carolina, the site is mapped within the Yorktown and Duplin Formation (Tertiary).

Seismic Site Class

The seismic design requirements for buildings and other structures are based on Seismic Design Category. Site Classification is required to determine the Seismic Design Category for a structure. The Site Classification is based on the upper 100 feet of the site profile defined by a weighted average value of either shear wave velocity, standard penetration resistance, or undrained shear strength in accordance with Section 20.4 of ASCE 7-10 and the North Carolina Building Code (NCSBC). Based on the soil properties observed at the site and as described on the exploration logs and results, our professional opinion is for that a **Seismic Site Classification of D** be considered for the project. Subsurface explorations at this site were extended to a maximum depth of 50 feet. The site properties below the exploration depth to 50 feet were estimated based on our experience and knowledge of geologic conditions of the general area. Additional deeper borings or geophysical testing may be performed to confirm the conditions below the current exploration depth.

Liquefaction

Liquefaction occurs when a rapid buildup in water pressure, caused by ground motion, pushes sand particles apart, resulting in a loss of strength and later densification as the water pressure dissipates. This loss of strength can cause bearing capacity failure while the densification can cause excessive settlement.

The amount of settlement is dependent on the magnitude and distance from a seismic event, and geologic age of the soil deposit. Based on the relatively mild ground motions associated with the design earthquake, the potential for liquefaction is negligible at this site.

Geotechnical Overview

Based upon the geotechnical conditions encountered in our exploration, the site is suitable for the proposed construction, provided that the recommendations given herein are implemented in the design and construction phases of this project. Our recommendations include earthwork during warmer/drier periods of the year, vibratory rolling the subgrade and isolated foundation undercut to remove relatively softer soil such as encountered in in Borings B-2, B-8, B-10, and B-13 to depths up to 4 feet below existing grade. Vertical construction should be delayed on proposed fill greater than 4

feet above existing grades, which should be monitored for settlement until it sufficiently diminishes as determined by the Geotechnical Engineer. In addition, cut across the building footprint will likely be too wet for immediate reuse as engineered fill.

The existing fill encountered in the borings appears suitable for foundation, floor slab, and pavement support after the recommended **Earthwork**. However, there is an inherent risk for the owner that compressible fill or unsuitable material within or buried by the fill. This risk of unforeseen conditions cannot be eliminated without completely removing the existing fill but can be reduced by following the recommendations contained in this report.

Performing earthwork operations during warmer periods of the year (May through October) will reduce the potential for problems associated with wet, unstable subgrades. Positive site drainage is essential to aid in maintaining stable subgrade conditions. Laboratory testing of near-surface soils samples revealed natural moisture content that is expected to be higher than the soil Plastic Limit, which suggests instability of the subgrade soils should be anticipated. For this reason, low ground pressure/tracked equipment should be anticipated for site preparation, especially in low-lying areas of the site adjacent to existing ditches.

Following the recommended **Earthwork**, the building can be supported on shallow foundations bearing on approved existing soils or structural fill compacted as recommended and sized for a maximum net allowable soil bearing pressure of 1,500 psf. The **Shallow Foundations** section addresses support of the building bearing on densified existing fill soils or structural fill. The **Floor Slabs** section addresses slab-on-grade support of the building.

A rigid or flexible pavement system is suitable for this site. The **Pavements** section addresses the design of pavement systems supported on the densified existing soils or structural fill.

The **General Comments** section provides an understanding of the report limitations.

Earthwork

Earthwork is anticipated to include demolition and removal of foundations, clearing and grubbing, excavations, and structural fill placement. The following sections provide recommendations for use in the preparation of specifications for the work.

Recommendations include critical quality criteria, as necessary, to render the site in the state considered in our geotechnical engineering evaluation for foundations, floor slabs, and pavements. Grading for the structure should incorporate the limits of the proposed structure plus 5 feet beyond proposed perimeter building walls and any exterior columns.

Site Preparation

Prior to placing fill, existing vegetation, topsoil, and root mats should be removed. Aggregate base course (if encountered) from existing structures and pavement can remain in-place if it withstands proofrolling. Based on the results of our exploration, topsoil thickness measurements ranged from approximately 2 inches to 8 inches with the exception of B-P4 with 17 inches. Topsoil may be reused in areas of the site to be landscaped but should not be used as structural fill or backfill. Deeper topsoil or organic-laden soils may be present in between exploration locations, especially in wet, poorly drained areas of the site such as in the vicinity of Boring B-P4. Stumps should be removed, and the hole somewhat enlarged for backfill with compacted fill.

Subgrade Preparation

After stripping and removing topsoil and once any areas of cut have been excavated to proposed subgrade elevation, the exposed subgrade soils in the building and pavement footprints should be densified in place using a medium weight vibratory roller. The purpose of the vibratory rolling is to densify the exposed subgrade soils for floor slab and pavement support and to potentially improve the foundation bearing soils. The roller should make at least six passes across the site, with the second set of three passes perpendicular to the first set of three passes with intermittent vibration activated. If water is brought to the surface by the vibratory rolling, the operation should be discontinued until the water subsides. Vibratory rolling should be completed during dry weather. Static rolling and additional repairs should be anticipated for areas too wet for vibratory rolling.

Proofrolling should be performed on the exposed subgrade soils in areas to receive fill or at the subgrade elevation with a loaded, tandem-axle dump truck (15 to 20 ton total vehicle weight) or similar rubber-tired construction equipment. Proofrolling is recommended as a means of detecting areas of soft or unstable subgrade soils. The proofrolling should be performed during a period of dry weather to avoid degrading an otherwise suitable subgrade. The proofrolling operations should be observed by a representative of the geotechnical engineer. Subgrade soils that exhibit excessive rutting or deflection during proofrolling should be repaired as directed by the field representative. Typical repairs include overexcavation followed by replacement with either properly compacted fill or by a subgrade stabilization fabric in conjunction with a sand fill or crushed stone.

If subgrade soils are unsuitable, they will require removal and replacement; however, if they are unstable due to excessive moisture, the most economical solution for remediation may be to scarify, dry and recompact the material. This remediation is most effective during the typically hotter months of the year (May to October). If construction is performed during the cooler period of the year, the timeline for scarifying, drying, and recompacting typically increases considerably and may lead to alternative remediation solutions. These solutions can include overexcavation of some or all of the unstable material to be backfilled with either approved structural fill or

geotextile and ABC Stone. Potential undercutting can be reduced if the site preparation work is performed during a period of dry weather and if construction traffic is kept to a minimum on prepared subgrades. We recommend that the contractor submit a unit rate cost for undercutting as part of the bidding process.

Existing Fill

As noted in **Geotechnical Characterization**, existing fill soils were encountered at the boring locations. Generally, floor slabs, foundations, and pavements could be supported on or above the existing fill soils that have been densified in place and withstand proofrolling. However, there is inherent risk for the owner that compressible fill or unsuitable material, within or buried by the fill, will not be discovered. This risk of unforeseen conditions cannot be eliminated without completely removing the existing fill but can be reduced by following the recommendations contained in this report.

If the owner elects to construct the footings, floor slabs, and pavements on the existing fill, the following protocol should be followed. Once areas of cut are excavated to proposed subgrade elevation and after vibratory densification, the entire area should be proof-rolled with heavy, rubber tire construction equipment, to aid in delineating areas of soft, or otherwise unsuitable soil. The bottom of footings should be checked with hand augers and Dynamic Cone Penetrometer (DCP) testing that extend through the existing fill material. Once any areas of unsuitable materials have been remediated, and the subgrade has passed the proof-roll/DCP testing, the existing soils that were removed can be evaluated for reuse as structural fill.

Settlement Monitoring

Settlement plates and settlement monuments should be used to monitor settlement in areas with fill greater than 4 feet above existing grades. After site stripping and prior to placing fill materials, settlement plates should be constructed to monitor the rates and magnitudes of settlement. To adequately monitor the fill settlement, we recommend that a minimum of one settlement plate per 10,000-square foot area of new fill greater than 4 feet in height above existing grades be installed across the site. The project surveyor should include initial elevation readings prior to fill placement and elevation readings should also be taken immediately after the addition of each section of riser pipe.

At completion of fill placement, we recommend placing settlement monuments on-top of the newly placed fill. The settlement plates and points should be read by the project surveyor daily during fill placement and twice weekly upon completion of fill placement. The data should be forwarded to the geotechnical engineer for weekly review and additional recommendations, if necessary. Once it is established that the rate of fill settlement is approaching zero, final grading can be performed and construction of the settlement sensitive features (e.g. foundations, curb and gutter, etc.) can commence. All

readings should be performed under the direction of a licensed surveyor. Based on our experience in the region, settlement should sufficiently diminish within four weeks.

The settlement plates should consist of square steel plates (2 feet by 2 feet by ¼-inch thick) buried at the top of the existing ground surface following clearing and grubbing operations. A riser pipe (0.5-inch diameter minimum) with sleeve should be attached to the plate and extended to above the top of the fill. See [Supporting Information](#) for details on typical settlement plates. The settlement monuments can consist of any point, such as wooden lathe or rebar, and should be protected from disturbance.

Utility Abandonment

Special precautions should be made to remove all underground utilities and their associated backfill as the structure’s foundations may overlay these materials. Terracon considers removing the utilities and underground structures and backfilling the resulting trenches to be the preferred method of abandonment. In-place abandonment by filling piping with grout should only be considered in the building footprint after checking the location of the piping in both plan and elevation space for potential conflict with the proposed foundations, construction, and new utilities. Care should be given to locating and addressing these items during the site preparation phase of the project. If overlooked, they could be detrimental to the long-term performance of the structure.

Excavation

We anticipate that excavations for the proposed construction can be accomplished with conventional earthmoving equipment. Low ground pressure/tracked equipment will likely be required for site preparation.

Fill Material Types

Fill (engineered fill) required to achieve design grade should be classified as structural fill and general fill. Structural fill is material used below, or within 5 feet of structures and pavements. General fill is material used to achieve grade outside of these areas. Earthen materials used for structural fill should meet the following material property requirements:

Soil Type ¹	USCS Classification	Acceptable Location for Placement
Imported Soil	SC, SM, SP	All locations and elevations
On-Site Soils	SM, SC	All locations and elevations

Soil Type ¹	USCS Classification	Acceptable Location for Placement
------------------------	---------------------	-----------------------------------

1. Structural fill should consist of approved materials free of organic matter and debris. Frozen materials should not be used, and fill should not be placed on frozen subgrade. A sample of each material type should be submitted to the Geotechnical Engineer for evaluation prior to use on this site.

Fine-grained soils such as clays and silts should not be reused as structural fill due to their moisture sensitivity when compared to the sandier soils available.

Fill Placement and Compaction Requirements

Structural and general fill should meet the following compaction requirements.

Item	Structural Fill	General Fill
Maximum Lift Thickness	9 inches or less in loose thickness when heavy, self-propelled compaction equipment is used 4 to 6 inches in loose thickness when hand-guided equipment (i.e. jumping jack or plate compactor) is used	Same as structural fill
Minimum Compaction Requirements ^{1,2,3}	95% of maximum 98% of maximum within 1-foot of pavement subgrade	92% of max.
Water Content Range ^{1, 3}	Within 2 percent of optimum moisture content	As required to achieve min. compaction requirements

1. Fill should be tested for moisture content and compaction during placement. If in-place density tests indicate the specified moisture or compaction limits have not been met, the area represented by the tests should be reworked and retested as required until the specified moisture and compaction requirements are achieved.
2. It is not necessary to achieve 95% compaction on the existing ground prior to placing fill or beginning construction. However, the subgrade should be evaluated by the Geotechnical Engineer prior to placing fill or beginning construction.
3. Maximum density and optimum water content as determined by the standard Proctor test (ASTM D 698).
4. If the granular material is a coarse sand or gravel, or of a uniform size, or has a low fines content, compaction comparison to relative density may be more

Item	Structural Fill	General Fill
------	-----------------	--------------

appropriate. In this case, granular materials should be compacted to at least 70% relative density (ASTM D 4253 and D 4254). Materials not amenable to density testing should be placed and compacted to a stable condition observed by the Geotechnical Engineer or representative.

Utility Trench Backfill

Any soft or unsuitable materials encountered at the bottom of utility trench excavations should be removed and replaced with structural fill or bedding material in accordance with public works specifications for the utility being supported. This recommendation is particularly applicable to utility work requiring grade control and/or in areas where subsequent grade raising could cause settlement in the subgrade supporting the utility. Trench excavation should not be conducted below a downward 1:1 projection from existing foundations without engineering review of shoring requirements and geotechnical observation during construction.

Trench backfill should be mechanically placed and compacted as discussed earlier in this report. Compaction of initial lifts should be accomplished with hand-operated tampers or other lightweight compactors. Where trenches are placed beneath slabs or footings, the backfill should satisfy the material requirements of engineered fill discussed in this report. Flooding or jetting for placement and compaction of backfill is not recommended.

Grading and Drainage

All grades must provide effective drainage away from the building during and after construction and should be maintained throughout the life of the structure. Water retained next to the building can result in soil movements greater than those discussed in this report. Greater movements can result in unacceptable differential floor slab and/or foundation movements, cracked slabs and walls, and roof leaks. The roof should have gutters/drains with downspouts that discharge onto splash blocks at a distance of at least 5 feet from the building.

Exposed ground should be sloped and maintained at a minimum 5% away from the building for at least 5 feet beyond the perimeter of the building. Locally, flatter grades may be necessary to transition ADA access requirements for flatwork. After building construction and landscaping have been completed, final grades should be verified to document effective drainage has been achieved. Grades around the structure should also be periodically inspected and adjusted, as necessary, as part of the structure's maintenance program. Where paving or flatwork abuts the structure, a maintenance program should be established to effectively seal and maintain joints and prevent surface water infiltration.

Earthwork Construction Considerations

Shallow excavations for the proposed structure are anticipated to be accomplished with conventional construction equipment. Earthwork operations should be performed during the warmer, drier periods of the year (May through October) to avoid problems associated with a wet subgrade.

Upon completion of filling and grading, care should be taken to maintain the subgrade water content prior to construction of grade-supported improvements such as floor slabs and pavements. Construction traffic over the completed subgrades should be avoided. The site should also be graded to prevent ponding of surface water on the prepared subgrades or in excavations. Water collecting over or adjacent to construction areas should be removed. If the subgrade freezes, desiccates, saturates, or is disturbed, the affected material should be removed, or the materials should be scarified, moisture conditioned, and recompacted prior to floor slab construction.

The groundwater table could be encountered in excavations, especially in overexcavation. A temporary dewatering system consisting of sumps with pumps may be necessary to in excavations depending on groundwater conditions at the time of construction. Excavations should remain dewatered until backfilled with compacted fill.

As a minimum, excavations should be performed in accordance with OSHA 29 CFR, Part 1926, Subpart P, "Excavations" and its appendices, and in accordance with any applicable local and/or state regulations.

Construction site safety is the sole responsibility of the contractor who controls the means, methods, and sequencing of construction operations. Under no circumstances shall the information provided herein be interpreted to mean Terracon is assuming responsibility for construction site safety or the contractor's activities; such responsibility shall neither be implied nor inferred.

Excavations or other activities resulting in ground disturbance have the potential to affect adjoining properties and structures. Our scope of services does not include review of available final grading information or consider potential temporary grading performed by the contractor for potential effects such as ground movement beyond the project limits. A preconstruction/ precondition survey should be conducted to document nearby property/infrastructure prior to any site development activity. Excavation or ground disturbance activities adjacent or near property lines should be monitored or instrumented for potential ground movements that could negatively affect adjoining property and/or structures.

Construction Observation and Testing

The earthwork efforts should be observed by the Geotechnical Engineer (or others under their direction). Observation should include documentation of adequate removal of surficial materials (vegetation, topsoil, and pavements), evaluation and remediation of existing fill materials, as well as proofrolling and mitigation of unsuitable areas delineated by the proofroll.

Each lift of compacted fill should be tested, evaluated, and reworked, as necessary, as recommended by the Geotechnical Engineer prior to placement of additional lifts. Each lift of fill should be tested for density and water content at a frequency of at least one test for every 2,500 square feet of compacted fill in the building areas and 5,000 square feet in pavement areas. Where not specified by local ordinance, one density and water content test should be performed for every 50 linear feet of compacted utility trench backfill and a minimum of one test performed for every 12 vertical inches of compacted backfill.

In areas of foundation excavations, the bearing subgrade should be evaluated by the Geotechnical Engineer. The bottom of footings should be checked with hand augers and Dynamic Cone Penetrometer (DCP) testing. If unanticipated conditions are observed, the Geotechnical Engineer should prescribe mitigation options.

In addition to the documentation of the essential parameters necessary for construction, the continuation of the Geotechnical Engineer into the construction phase of the project provides the continuity to maintain the Geotechnical Engineer’s evaluation of subsurface conditions, including assessing variations and associated design changes.

Shallow Foundations

If the site has been prepared in accordance with the requirements noted in **Earthwork**, the following design parameters are applicable for shallow foundations.

Design Parameters – Compressive Loads

Item	Description
Maximum Net Allowable Bearing Pressure ^{1, 2}	1,500 psf
Required Bearing Stratum ³	Approved existing soils or structural fill
Minimum Foundation Dimensions	Per NC Building Code: Columns: 24 inches Continuous: 16 inches

Item	Description
	Thickened: 12 inches
Sliding Resistance ⁴	0.35 ultimate coefficient of friction
Minimum Embedment below Finished Grade ⁵	12 inches
Estimated Total Settlement from Structural Loads ²	Less than 1-inch
Estimated Differential Settlement ^{2, 6}	Less than 0.5 inches.

1. The maximum net allowable bearing pressure is the pressure in excess of the minimum surrounding overburden pressure at the footing base elevation. Values assume that exterior grades are no steeper than 20% within 10 feet of structure. The maximum net allowable bearing pressure may be increased by 1/3 for transient wind loads and seismic loads.
2. Values provided are for maximum loads noted in [Project Description](#). Additional geotechnical consultation will be necessary if higher loads are anticipated.
3. Unsuitable or soft soils should be overexcavated and replaced per the recommendations presented in [Earthwork](#).
4. Can be used to compute sliding resistance where foundations are placed on suitable soil/materials. Frictional resistance for granular materials is dependent on the bearing pressure which may vary due to load combinations.
5. Embedment necessary to minimize the effects of frost and/or seasonal water content variations. For sloping ground, maintain depth below the lowest adjacent exterior grade within 5 horizontal feet of the structure.
6. Differential settlements are noted for equivalent-loaded foundations and bearing elevation as measured over a span of 50 feet.

Design Parameters – Overturning and Uplift Loads

Shallow foundations subjected to overturning loads should be proportioned such that the resultant eccentricity is maintained in the center-third of the foundation (e.g., $e < b/6$, where b is the foundation width). This requirement is intended to keep the entire foundation area in compression during the extreme lateral/overturning load event. Foundation oversizing may be required to satisfy this condition.

Uplift resistance of spread footings can be developed from the effective weight of the footing and the overlying soils with consideration to the building code basic load combinations.

Item	Description
Soil Moist Unit Weight	110 pcf
Soil Effective Unit Weight¹	48 pcf
Soil weight included in uplift resistance	Soil included within the prism extending up from the top perimeter of the footing at an angle of 20 degrees from vertical to ground surface

1. Effective (or buoyant) unit weight should be used for soil above the foundation level and below a water level. The high groundwater level should be used in uplift design as applicable.

Foundation Construction Considerations

As noted in **Earthwork**, the footing excavations should be evaluated under the observation of the Geotechnical Engineer. This is an essential part of the construction process. The Geotechnical Engineer should use a combination of hand auger borings and dynamic cone penetrometer (DCP) testing to determine the suitability of the bearing materials for the design bearing pressure. DCP testing should be performed to a depth of 3 to 5 feet below the bottom of foundation excavation and through any existing fill soils. Excessively soft, loose, or wet bearing soils should be over excavated to a depth recommended by the geotechnical engineer. The excavated soils should be replaced with structural fill or washed, crushed stone (NCDOT No. 57) wrapped in a geotextile fabric (Mirafi 140 N or equivalent). The need for the geotextile fabric with the crushed stone should be determined by the Geotechnical Engineer during construction based on sloughing/caving soils and excavation observations. However, footings could bear directly on the soils after over excavation if approved by the Geotechnical Engineer.

The base of all foundation excavations should be free of water and loose soil prior to placing concrete. Concrete should be placed soon after excavating to reduce bearing soil disturbance. Should the soils at bearing level become excessively disturbed or saturated, the affected soil should be removed prior to placing concrete.

Floor Slabs

Design parameters for floor slabs assume the requirements for **Earthwork** have been followed. Specific attention should be given to positive drainage away from the structure and positive drainage of the aggregate base beneath the floor slab.

Floor Slab Design Parameters

Item	Description
Floor Slab Support¹	Suitable existing soils or new structural fill compacted in accordance with Earthwork section of this report.
Estimated Modulus of Subgrade Reaction²	100 pounds per square inch per inch (psi/in) for point loads
Aggregate base course/capillary break³	Minimum 4 inches of free-draining granular material (less than 5% passing the U.S. No. 200 sieve) such as NCDOT No. 57 Stone.

1. Floor slabs should be structurally independent of building footings or walls to reduce the possibility of floor slab cracking caused by differential movements between the slab and foundation.
2. Modulus of subgrade reaction is an estimated value based upon our experience with the subgrade condition, the requirements noted in **Earthwork**, and the floor slab support as noted in this table. It is provided for point loads. For large area loads the modulus of subgrade reaction would be lower.
3. Other design considerations such as cold temperatures and condensation development could warrant more extensive design provisions.

The use of a vapor retarder should be considered beneath concrete slabs on grade covered with wood, tile, carpet, or other moisture sensitive or impervious coverings, when the project includes humidity-controlled areas, or when the slab will support equipment sensitive to moisture. When conditions warrant the use of a vapor retarder, the slab designer should refer to ACI 302 and/or ACI 360 for procedures and cautions regarding the use and placement of a vapor retarder.

Saw-cut contraction joints should be placed in the slab to help control the location and extent of cracking. For additional recommendations, refer to the ACI Design Manual. Joints or cracks should be sealed with a waterproof, non-extruding compressible compound specifically recommended for heavy duty concrete pavement and wet environments.

Where floor slabs are tied to perimeter walls or turn-down slabs to meet structural or other construction objectives, our experience indicates differential movement between the walls and slabs will likely be observed in adjacent slab expansion joints or floor slab cracks beyond the length of the structural dowels. The Structural Engineer should account for potential differential settlement through use of sufficient control joints, appropriate reinforcing or other means.

Floor Slab Construction Considerations

On most project sites, the site grading is generally accomplished early in the construction phase. However, as construction proceeds, the subgrade may be disturbed due to utility excavations, construction traffic, desiccation, rainfall, etc. As a result, the floor slab subgrade may not be suitable for placement of base stone and concrete and corrective action will be required to repair the damaged areas.

Finished subgrade, within and for at least 10 feet beyond the floor slab, should be protected from traffic, rutting, or other disturbance and maintained in a relatively moist condition until floor slabs are constructed. If the subgrade should become damaged or desiccated prior to construction of floor slabs, the affected material should be removed, and structural fill should be added to replace the resulting excavation. Final conditioning of the finished subgrade should be performed immediately prior to placement of the floor slab support course.

The Geotechnical Engineer should observe the condition of the floor slab subgrades immediately prior to placement of the floor slab support course, reinforcing steel, and concrete. Attention should be paid to high traffic areas that were rutted and disturbed earlier, and to areas where backfilled trenches are located.

Lateral Earth Pressures

Design Parameters

Structures with unbalanced backfill levels on opposite sides should be designed for earth pressures at least equal to values indicated in the following table. Earth pressures will be influenced by structural design of the walls, conditions of wall restraint, methods of construction, and/or compaction and the strength of the materials being restrained. Two wall restraint conditions are shown in the diagram below. Active earth pressure is commonly used for design of free-standing cantilever retaining walls and assumes wall movement. The "at-rest" condition assumes no wall movement and is commonly used for basement walls, loading dock walls, or other walls restrained at the top. We recommend using the at-rest condition for the retaining walls of the structure. The recommended design lateral earth pressures do not include a factor of safety and do not provide for possible hydrostatic pressure on the walls (unless stated).

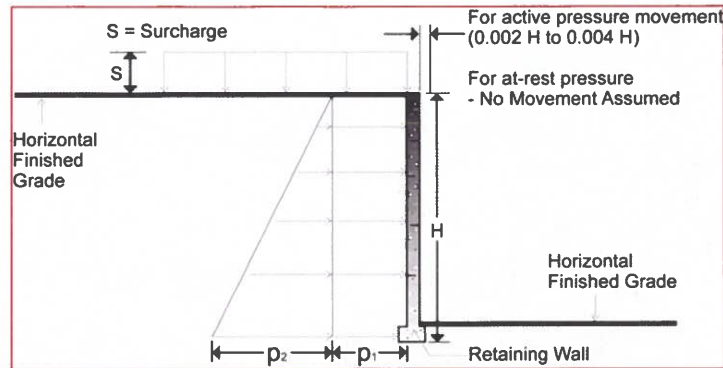

Lateral Earth Pressure Design Parameters

Earth Pressure Condition ¹	Coefficient for Backfill Type ²	Surcharge Pressure ³ p ₁ (psf)	Equivalent Fluid Pressures (psf) ^{2,4}	
			Unsaturated ⁵	Submerged ⁵
Active (K _a)	Granular - 0.33	(0.33)S	(40)H	(80)H
At-Rest (K _o)	Granular - 0.50	(0.50)S	(60)H	(90)H

1. For active earth pressure, wall must rotate about base, with top lateral movements 0.002 H to 0.004 H, where H is wall height. For passive earth pressure, wall must move horizontally to mobilize resistance. Fat clay or other expansive soils should not be used as backfill behind the wall.
2. Uniform, horizontal backfill, compacted to at least 95% of the ASTM D 698 maximum dry density, rendering a maximum unit weight of 120 pcf.
3. Uniform surcharge, where S is surcharge pressure.
4. Loading from heavy compaction equipment is not included.
5. To achieve "Unsaturated" conditions, follow guidelines in **Subsurface Drainage for Below-Grade Walls** below. "Submerged" conditions are recommended when drainage behind walls is not incorporated into the design.

Backfill placed against structures should consist of granular soils. For the granular values to be valid, the granular backfill must extend out and up from the base of the wall at an angle of at least 45 degrees from vertical for the active case.

Footings, floor slabs or other loads bearing on backfill behind walls may have a significant influence on the lateral earth pressure. Placing footings within wall backfill and in the zone of active soil influence on the wall should be avoided unless structural analyses indicate the wall can safely withstand the increased pressure.

The lateral earth pressure recommendations given in this section are applicable to the design of rigid retaining walls subject to slight rotation, such as cantilever, or gravity type concrete walls. These recommendations are not applicable to the design of modular block - geogrid reinforced backfill walls (also termed MSE walls). Recommendations covering these types of wall systems are beyond the scope of services for this

assignment. However, we would be pleased to develop a proposal for evaluation and design of such wall systems upon request.

Subsurface Drainage for Below-Grade Walls

A perforated rigid plastic drain line installed behind the base of walls and extends below adjacent grade is recommended to prevent hydrostatic loading on the walls. The invert of a drain line around a below-grade building area or exterior retaining wall should be placed near foundation bearing level. The drain line should be sloped to provide positive gravity drainage to daylight or to a sump pit and pump. The drain line should be surrounded by clean, free-draining granular material having less than 5% passing the No. 200 sieve, such as No. 57 aggregate. The free-draining aggregate should be encapsulated in a filter fabric.

As an alternative to free-draining granular fill, a prefabricated drainage structure may be used. A prefabricated drainage structure is a plastic drainage core or mesh which is covered with filter fabric to prevent soil intrusion and is fastened to the wall prior to placing backfill.

Pavements

General Pavement Comments

Pavement designs are provided for the traffic conditions and pavement life conditions as noted in **Project Description** and in the following sections of this report. A critical aspect of pavement performance is site preparation. Pavement designs noted in this section must be applied to the site which has been prepared as recommended in the **Earthwork** section.

Pavement Design Parameters

A California Bearing Ratio (CBR) of 5 was used for the subgrade for the pavement designs. The value was empirically derived based upon our experience with the sandy subgrade soils and our expectation of the quality of the subgrade as prescribed by the **Site Preparation** conditions as outlined in **Earthwork**. A minimum pavement section thickness was also included in the design for future maintenance.

Pavement Section Thicknesses

The following table provides our opinion of minimum thickness for AC sections:

Asphaltic Concrete Design

Layer	Asphaltic Concrete Design		
	NCDOT Grading ¹	Automobile Areas (Light Duty)	Main Drives and Truck Access Areas (Medium Duty)
AC Surface	S9.5B	3 ²	1.5
AC Intermediate	I19.0C	--	2.5
Aggregate Base	ABC	6	8

1. All materials should meet the current North Carolina Department of Transportation Standard Specifications
2. Placed in two equal lifts.
3. See [Project Description](#) for more specifics regarding traffic assumptions.

The following table provides our estimated minimum thickness of PCC pavements.

Portland Cement Concrete Design

Layer	Specification ¹	Thickness (inches)		
		Automobile Areas (Light Duty)	Main Drives and Truck Access Areas (Medium Duty)	Heavy Repetitive Loading ⁴
PCC ³	4,000 psi		5	7
Aggregate Base	NCDOT ABC ³		4 ¹	4

1. Crushed Aggregate Base Course is recommended for construction purposes. Concrete could be placed directly on an approved subgrade. However, stormwater can quickly degrade exposed subgrades without the crushed aggregate base course leading to additional subgrade repair.
2. See [Project Description](#) for more specifics regarding traffic classifications.
3. All materials should meet the current North Carolina Department of Transportation (NCDOT) Standard Specifications.

Portland Cement Concrete Design

Layer	Specification ¹	Thickness (inches)		
		Automobile Areas (Light Duty)	Main Drives and Truck Access Areas (Medium Duty)	Heavy Repetitive Loading ⁴

4. In areas of anticipated heavy traffic, fire trucks, delivery trucks, or concentrated loads (e.g. dumpster pads), and areas with repeated turning or maneuvering of heavy vehicles.

For subgrade instability that could develop due to the weather, we recommend that contingencies be placed in the budget for stabilization of the subgrade in planned pavement areas using a geosynthetic fabric or geogrid and additional ABC stone. The geosynthetic or geogrid could be left off corridors/easements for deeper utility lines for ease of construction.

Areas for parking of heavy vehicles, concentrated turn areas, and start/stop maneuvers could require thicker pavement sections. Edge restraints (i.e. concrete curbs or aggregate shoulders) should be planned along curves and areas of maneuvering vehicles.

Proper joint spacing will also be required to prevent excessive slab curling and shrinkage cracking. Joints should be sealed to prevent entry of foreign material and doweled where necessary for load transfer. PCC pavement details for joint spacing, joint reinforcement, and joint sealing should be prepared in accordance with ACI 330 and ACI 325.

Where practical, we recommend early-entry cutting of crack-control joints in PCC pavements. Cutting of the concrete in its "green" state typically reduces the potential for micro-cracking of the pavements prior to the crack control joints being formed, compared to cutting the joints after the concrete has fully set. Micro-cracking of pavements may lead to crack formation in locations other than the sawed joints, and/or reduction of fatigue life of the pavement.

Openings in pavements, such as decorative landscaped areas, are sources for water infiltration into surrounding pavement systems. Water can collect in the islands and migrate into the surrounding subgrade soils thereby degrading support of the pavement. Islands with raised concrete curbs, irrigated foliage, and low permeability near-surface soils are particular areas of concern. The civil design for the pavements with these conditions should include features to restrict or collect and discharge excess water from the islands. Examples of features are edge drains connected to the stormwater collection system, longitudinal subdrains, or other suitable outlets and impermeable barriers preventing lateral migration of water such as a cutoff wall installed to a depth below the pavement structure.

Pavement Drainage

Pavements should be sloped to provide rapid drainage of surface water. Water allowed to pond on or adjacent to the pavements could saturate the subgrade and contribute to premature pavement deterioration. In addition, the pavement subgrade should be graded to provide positive drainage within the granular base section. Appropriate sub-drainage or connection to a suitable daylight outlet should be provided to remove water from the granular subbase.

Based on the possibility of shallow and/or perched groundwater, we recommend installing a pavement subdrain system to control groundwater, improve stability, and improve long-term pavement performance.

Pavement Maintenance

The pavement sections represent minimum recommended thicknesses and, as such, periodic upkeep should be anticipated. Preventive maintenance should be planned and provided for through an on-going pavement management program. Maintenance activities are intended to slow the rate of pavement deterioration and to preserve the pavement investment. Pavement care consists of both localized (e.g., crack and joint sealing and patching) and global maintenance (e.g., surface sealing). Additional engineering consultation is recommended to determine the type and extent of a cost-effective program. Even with periodic maintenance, some movements and related cracking may still occur, and repairs may be required.

Pavement performance is affected by its surroundings. In addition to providing preventive maintenance, the civil engineer should consider the following recommendations in the design and layout of pavements:

- Final grade adjacent to paved areas should slope down from the edges at a minimum 2%.
- Subgrade and pavement surfaces should have a minimum 2% slope to promote proper surface drainage.
- Install pavement drainage systems surrounding areas anticipated for frequent wetting.
- Install joint sealant and seal cracks immediately.
- Seal all landscaped areas in or adjacent to pavements to reduce moisture migration to subgrade soils.
- Place compacted backfill against the exterior side of curb and gutter.
- Place curb, gutter and/or sidewalk directly on compacted subgrade soils rather than on unbound granular base course materials

General Comments

Our analysis and opinions are based upon our understanding of the project, the geotechnical conditions in the area, and the data obtained from our site exploration. Variations will occur between exploration point locations or due to the modifying effects of construction or weather. The nature and extent of such variations may not become evident until during or after construction. Terracon should be retained as the Geotechnical Engineer, where noted in this report, to provide observation and testing services during pertinent construction phases. If variations appear, we can provide further evaluation and supplemental recommendations. If variations are noted in the absence of our observation and testing services on-site, we should be immediately notified so that we can provide evaluation and supplemental recommendations.

Our Scope of Services does not include either specifically or by implication any environmental or biological (e.g., mold, fungi, bacteria) assessment of the site or identification or prevention of pollutants, hazardous materials or conditions. If the owner is concerned about the potential for such contamination or pollution, other studies should be undertaken.

Our services and any correspondence are intended for the sole benefit and exclusive use of our client for specific application to the project discussed and are accomplished in accordance with generally accepted geotechnical engineering practices with no third-party beneficiaries intended. Any third-party access to services or correspondence is solely for information purposes to support the services provided by Terracon to our client. Reliance upon the services and any work product is limited to our client and is not intended for third parties. Any use or reliance of the provided information by third parties is done solely at their own risk. No warranties, either express or implied, are intended or made.

Site characteristics as provided are for design purposes and not to estimate excavation cost. Any use of our report in that regard is done at the sole risk of the excavating cost estimator as there may be variations on the site that are not apparent in the data that could significantly effect excavation cost. Any parties charged with estimating excavation costs should seek their own site characterization for specific purposes to obtain the specific level of detail necessary for costing. Site safety and cost estimating including excavation support and dewatering requirements/design are the responsibility of others. Construction and site development have the potential to affect adjacent properties. Such impacts can include damages due to vibration, modification of groundwater/surface water flow during construction, foundation movement due to undermining or subsidence from excavation, as well as noise or air quality concerns. Evaluation of these items on nearby properties are commonly associated with contractor means and methods and are not addressed in this report. The owner and contractor should consider a preconstruction/precondition survey of surrounding development. If changes in the nature, design, or location of the project are planned, our conclusions and

Geotechnical Engineering Report

Eastern Elementary | Washington, North Carolina

November 17, 2023 | Terracon Project No. 72235092



recommendations shall not be considered valid unless we review the changes and either verify or modify our conclusions in writing.

Geotechnical Engineering Report

Eastern Elementary | Washington, North Carolina

November 17, 2023 | Terracon Project No. 72235092



Figures

Contents:

GeoModel (three pages)

Note: All attachments are one page unless noted above.

GeoModel

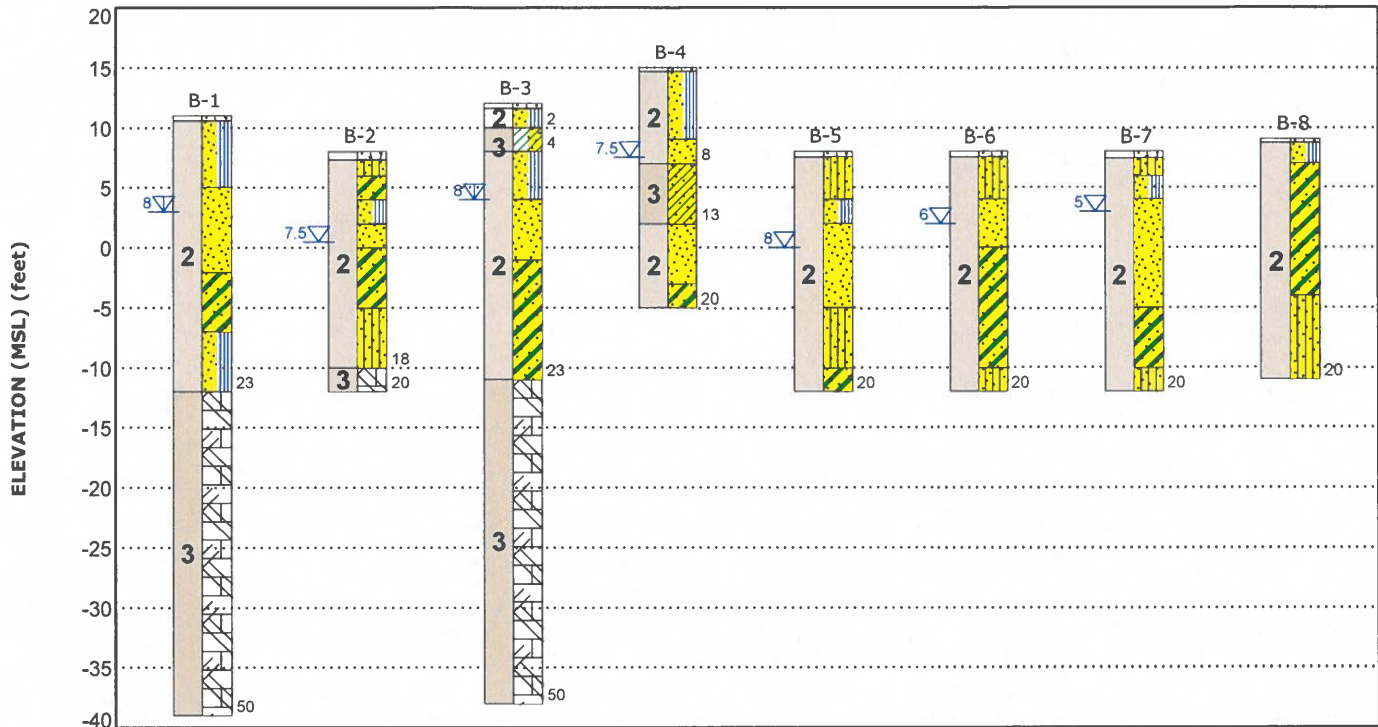

This is not a cross section. This is intended to display the Geotechnical Model only. See individual logs for more detailed conditions.

Model Layer	Layer Name	General Description	Legend	
1	Existing Fill	Sand, trace amounts of debris	Topsoil	Poorly-graded Sand with Silt
2	Sand	Very loose to medium dense sand with variable amounts of silt and clay	Poorly-graded Sand	Clayey Sand
3	Clay	Medium stiff to stiff clay with variable amounts of sand	Weathered Limestone	Silty Sand
4	Limestone	Limestone	Lean Clay with Sand	Sandy Lean Clay

- First Water Observation
- Second Water Observation

Groundwater levels are temporal. The levels shown are representative of the date and time of our exploration. Significant changes are possible over time. Water levels shown are as measured during and/or after drilling. In some cases, boring advancement methods mask the presence/absence of groundwater. See individual logs for details.

NOTES:

Layering shown on this figure has been developed by the geotechnical engineer for purposes of modeling the subsurface conditions as required for the subsequent geotechnical engineering for this project. Numbers adjacent to soil column indicate depth below ground surface.

GeoModel

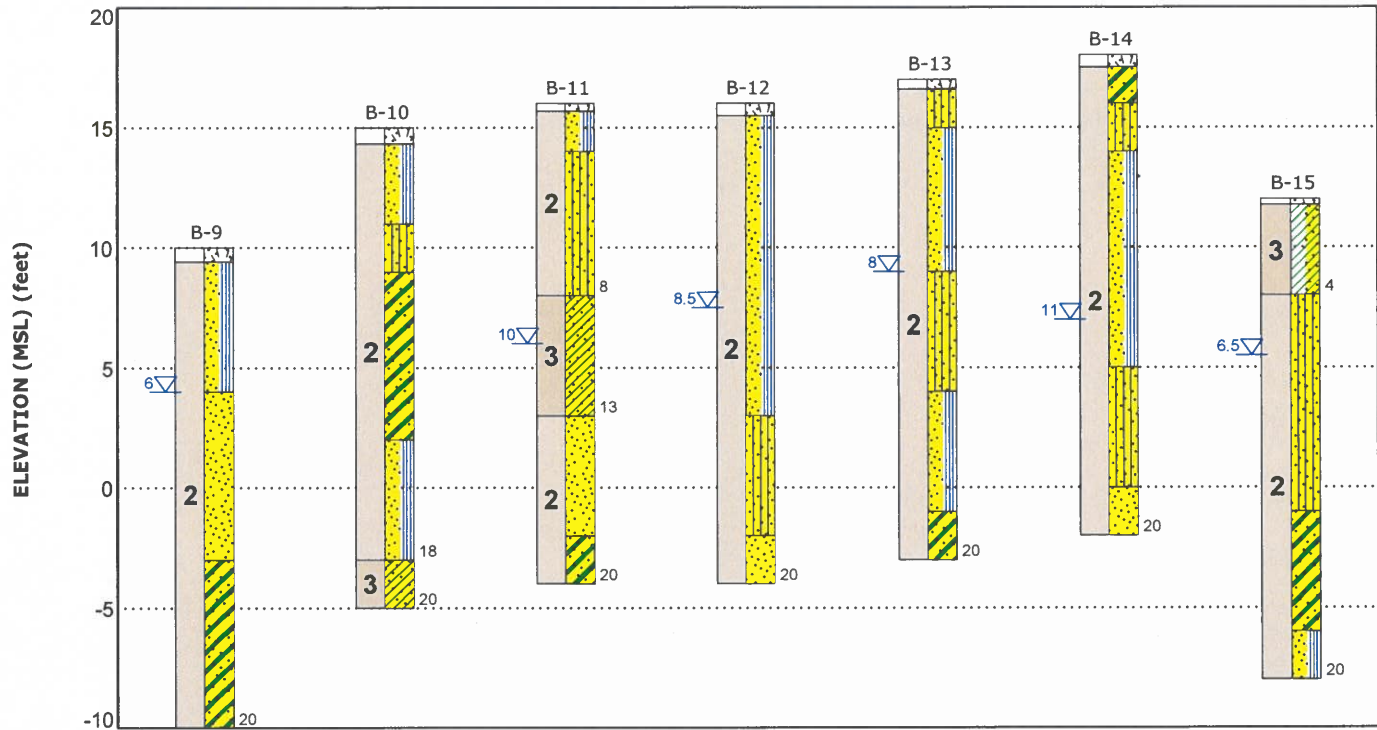

This is not a cross section. This is intended to display the Geotechnical Model only. See individual logs for more detailed conditions.

Model Layer	Layer Name	General Description	Legend	
1	Existing Fill	Sand, trace amounts of debris	Topsoil	Poorly-graded Sand with Silt
2	Sand	Very loose to medium dense sand with variable amounts of silt and clay	Poorly-graded Sand	Clayey Sand
3	Clay	Medium stiff to stiff clay with variable amounts of sand	Silty Sand	Sandy Lean Clay
4	Limestone	Limestone	Lean Clay with Sand	

First Water Observation
 Second Water Observation

Groundwater levels are temporal. The levels shown are representative of the date and time of our exploration. Significant changes are possible over time. Water levels shown are as measured during and/or after drilling. In some cases, boring advancement methods mask the presence/absence of groundwater. See individual logs for details.

NOTES:

Layering shown on this figure has been developed by the geotechnical engineer for purposes of modeling the subsurface conditions as required for the subsequent geotechnical engineering for this project. Numbers adjacent to soil column indicate depth below ground surface.

GeoModel

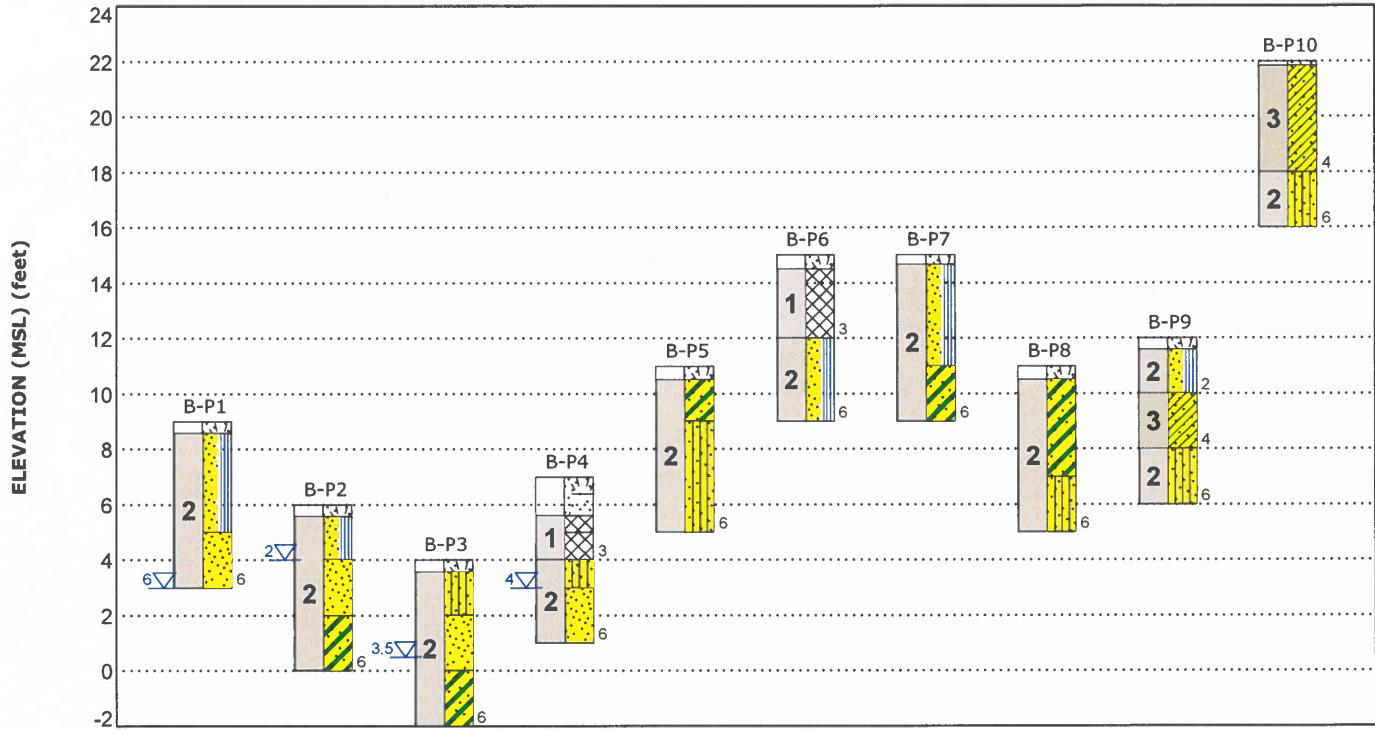

This is not a cross section. This is intended to display the Geotechnical Model only. See individual logs for more detailed conditions.

Model Layer	Layer Name	General Description	Legend	
1	Existing Fill	Sand, trace amounts of debris	Topsoil	Poorly-graded Sand with Silt
2	Sand	Very loose to medium dense sand with variable amounts of silt and clay	Poorly-graded Sand	Clayey Sand
3	Clay	Medium stiff to stiff clay with variable amounts of sand	Silty Sand	Fill
4	Limestone	Limestone	Sandy Lean Clay	

- First Water Observation
- Second Water Observation

Groundwater levels are temporal. The levels shown are representative of the date and time of our exploration. Significant changes are possible over time. Water levels shown are as measured during and/or after drilling. In some cases, boring advancement methods mask the presence/absence of groundwater. See individual logs for details.

NOTES:

Layering shown on this figure has been developed by the geotechnical engineer for purposes of modeling the subsurface conditions as required for the subsequent geotechnical engineering for this project. Numbers adjacent to soil column indicate depth below ground surface.



Attachments

Exploration and Testing Procedures

Field Exploration

Number of Soundings	Approximate Sounding Depth (feet) ¹	Location
13 (B-2, B-4 through B-15)	20	Proposed Building
2 (B-1 and B-3)	50	Proposed Building/Cafeteria and Gymnasium
10 (B-P1 through B-P10)	6	Planned Parking and Driveways

1. Referenced from existing ground surface.

Exploration Layout and Elevations: Terracon personnel provided the exploration layout using handheld GPS equipment (estimated horizontal accuracy of about ± 15 feet) and referencing existing site features. Approximate ground surface elevations were estimated from Google Earth Pro™. If elevations and a more precise exploration layout are desired, we recommend our locations be surveyed.

Standard Penetration Testing (SPT): We advanced the SPT borings with a track-mounted rotary drill rig using mud rotary procedures. Four samples were obtained in the upper 10 feet of each boring and at intervals of 5 feet thereafter. In the thin-walled tube sampling procedure, a thin-walled, seamless steel tube with a sharp cutting edge was pushed hydraulically into the soil to obtain a relatively undisturbed sample. In the split-barrel sampling procedure, a standard 2-inch outer diameter split-barrel sampling spoon was driven into the ground by a 140-pound automatic hammer falling a distance of 30 inches. The number of blows required to advance the sampling spoon the last 12 inches of a normal 18-inch penetration is recorded as the Standard Penetration Test (SPT) resistance value. The SPT resistance values, also referred to as N-values, are indicated on the boring logs at the test depths. We observed and recorded groundwater levels during and after drilling and sampling. For safety purposes, all borings were backfilled with soil cuttings after their completion.

The sampling depths, penetration distances, and other sampling information was recorded on the field boring logs. The samples were placed in appropriate containers and taken to our soil laboratory for testing and classification by a Geotechnical Engineer. Our exploration team prepared field boring logs as part of the drilling operations. These field logs included visual classifications of the materials observed during drilling and our interpretation of the subsurface conditions between samples. Final boring logs were prepared from the field logs. The final boring logs represent the Geotechnical Engineer's interpretation of the field logs and include modifications based on observations and tests

Geotechnical Engineering Report

Eastern Elementary | Washington, North Carolina

November 17, 2023 | Terracon Project No. 72235092



Laboratory Testing

The project engineer reviewed the field data and assigned laboratory tests. The laboratory testing program included the following types of tests:

- Moisture Content
- Grain-Size Analysis
- Atterberg Limits

The laboratory testing program often included examination of soil samples by an engineer. Based on the results of our field and laboratory programs, we described and classified the soil samples in accordance with the Unified Soil Classification System.

Photography Log

Photos taken during site visits on September 19, 2023 September 27, 2023.



Site facing northwest



Gravel drive facing north from Maple Street



Site facing east



Existing ditch near Boring P-9 facing south

Geotechnical Engineering Report

Eastern Elementary | Washington, North Carolina

November 17, 2023 | Terracon Project No. 72235092

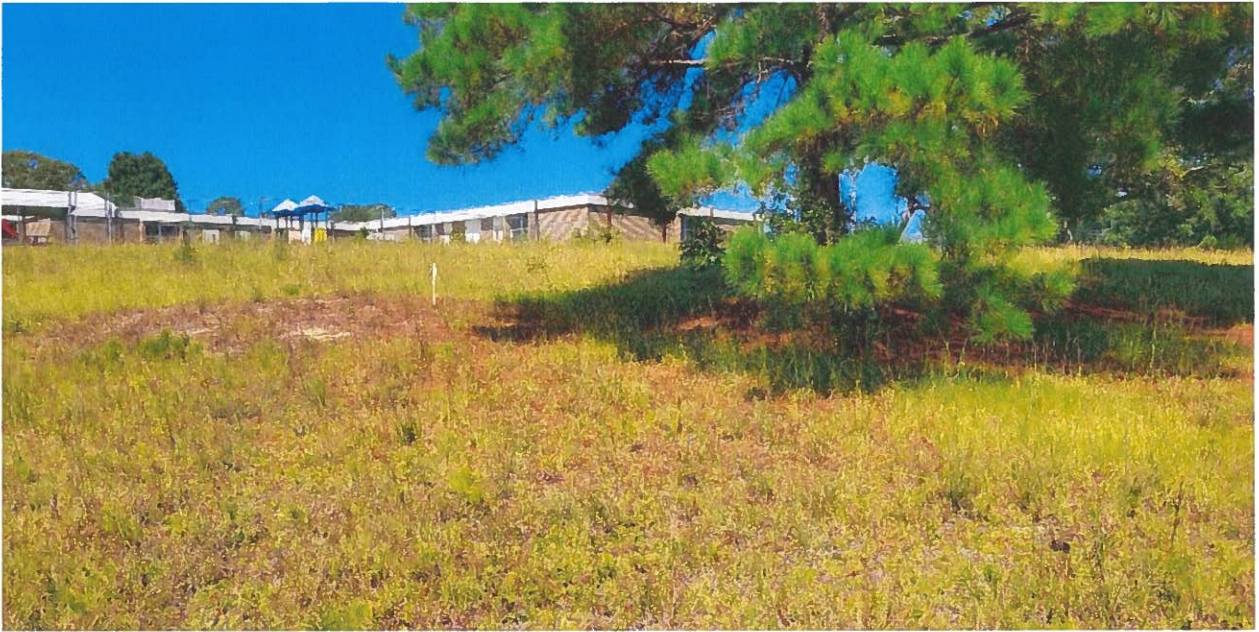

Boring B-P10



Boring B-P2 Facing southeast

Site Location and Exploration Plans

Contents:

Site Location

Exploration Plan

Note: All attachments are one page unless noted above.

Site Location

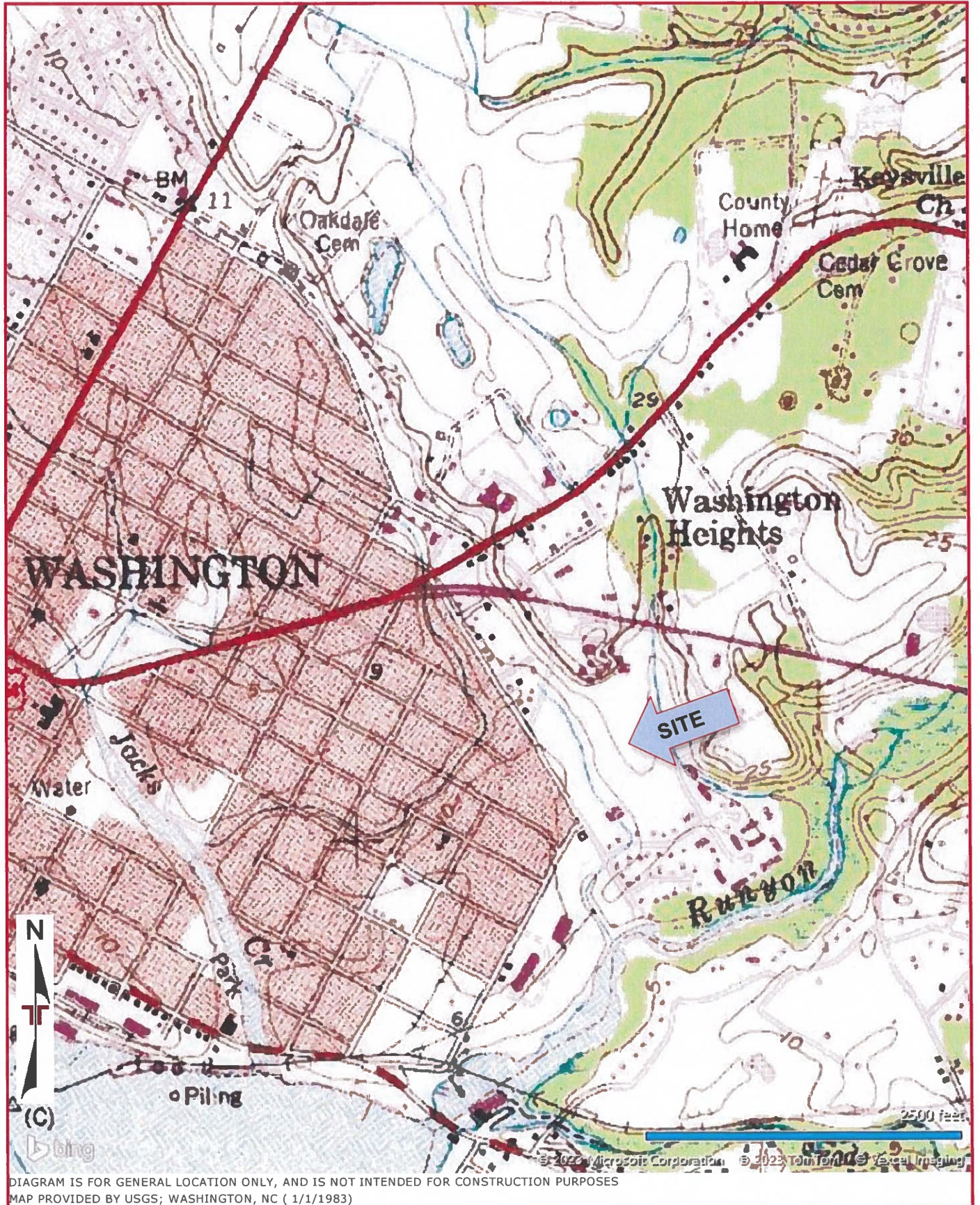

Exploration Plan

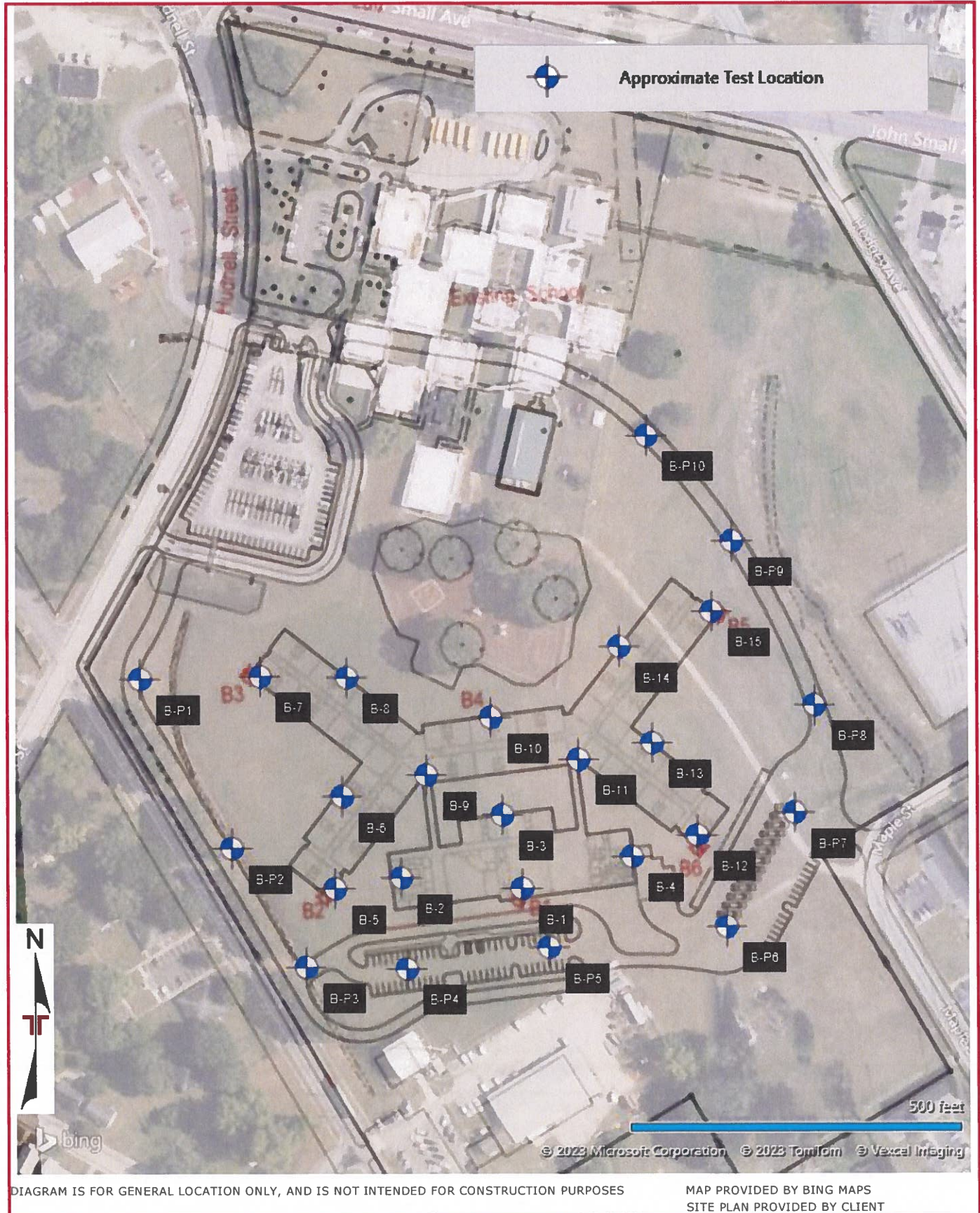

DIAGRAM IS FOR GENERAL LOCATION ONLY, AND IS NOT INTENDED FOR CONSTRUCTION PURPOSES

MAP PROVIDED BY BING MAPS
SITE PLAN PROVIDED BY CLIENT

Exploration and Laboratory Results

Contents:

Exploration Logs (B-01 through B-15 and B-P1 through B-P10)

Grain Size Distribution (two pages)

Atterberg Limits

Report of a Soil Evaluation for Stormwater Treatment (four pages)

Note: All attachments are one page unless noted above.

Boring Log No. B-1



Model Layer	Graphic Log	Location: See Exploration Plan Latitude: 35.5438° Longitude: -77.0349°	Depth (Ft.)	Elevation: 11 (Ft.) +/-	Depth (Ft.)	Water Level Observations	Sample Type	Field Test Results	Water Content (%)	Atterberg Limits	
										LL-PL-PI	Percent Fines
		Depth (Ft.)									
		0.4 TOPSOIL , 5 inches		10.58				2-1-2-2 N=3			
		POORLY GRADED SAND WITH SILT (SP-SM) , tannish brown to light tan, very loose to medium dense						2-3-4-6 N=7			
		6.0		5				3-7-9-7 N=16			
		POORLY GRADED SAND (SP) , light tan, medium dense						8-8-7-8 N=15			
								5-5-6-6 N=11			
2		13.0		-2							
		CLAYEY SAND (SC) , with shell fragments, dark gray, loose						4-3-3-3 N=6			
		18.0		-7							
		POORLY GRADED SAND WITH SILT (SP-SM) , with shell fragments, light tan to tannish brown, medium dense						1-4-11-11 N=15			
		23.0		-12							
		LIMESTONE , tan, light gray and dark gray, contains shell fragments						9-8-5-6 N=13			
								7-8-8-7 N=16			
								9-8-8-7 N=16			
3											
								10-8-6-5 N=14			
								12-8-6-4 N=14			
								10-9-9-7 N=18			
		50.0		-39							
		Boring Terminated at 50 Feet									

See **Exploration and Testing Procedures** for a description of field and laboratory procedures used and additional data (If any).
 See **Supporting Information** for explanation of symbols and abbreviations.

Notes

Elevation Reference: Approximate elevation obtained from Google Earth Pro

Water Level Observations

-  While drilling
-  After 24 hours

Drill Rig
CME 55

Hammer Type
Automatic

Driller
Tim. D

Logged by
L. West

Boring Started
10-13-2023

Boring Completed
10-13-2023

Advancement Method
Mud Rotary

Abandonment Method
Boring backfilled with soil cuttings upon completion.

Boring Log No. B-2

Model Layer	Graphic Log	Location: See Exploration Plan Latitude: 35.5438° Longitude: -77.0349°	Depth (Ft.)	Elevation: 8 (Ft.) +/-	Water Level Observations	Sample Type	Field Test Results	Water Content (%)	Atterberg Limits	
									LL-PL-PI	Percent Fines
		Depth (Ft.)								
		0.7 TOPSOIL , 8 inches	7.33							
2		2.0 SILTY SAND (SM) , dark brown and tannish brown, loose	6			1-2-2-2 N=4	9.4			
		CLAYEY SAND (SC) , gray and orange, very loose				2-1-1-1 N=2	21.7			
		4.0 POORLY GRADED SAND WITH SILT (SP-SM) , gray, loose	4			3-2-2-2 N=4	20.5	NP	6	
		6.0 POORLY GRADED SAND (SP) , light tan, very loose	2			3-2-1-1 N=3	20.2			
		8.0 CLAYEY SAND (SC) , with shell fragments, dark gray, loose	0			2-3-3-4 N=6	19.1			
		13.0 SILTY SAND (SM) , with shell fragments, tannish brown, medium dense	-5			4-4-6-8 N=10	27.1			
3		18.0 LIMESTONE , light gray, contains shell fragments	-10			8-7-6-4 N=13	20.1			
		20.0	-12							
Boring Terminated at 20 Feet										

See **Exploration and Testing Procedures** for a description of field and laboratory procedures used and additional data (If any).
 See **Supporting Information** for explanation of symbols and abbreviations.

Notes
 Elevation Reference: Approximate elevation obtained from Google Earth Pro

Water Level Observations
 While drilling

Advancement Method
 Mud Rotary

Abandonment Method
 Boring backfilled with soil cuttings upon completion.

Drill Rig
 CME 55
Hammer Type
 Automatic
Driller
 Tim. D
Logged by
 L. West
Boring Started
 10-13-2023
Boring Completed
 10-13-2023

Boring Log No. B-3

Model Layer	Graphic Log	Location: See Exploration Plan Latitude: 35.5438° Longitude: -77.0349°	Depth (Ft.)	Elevation: 12 (Ft.) +/-	Water Level Observations	Sample Type	Field Test Results	Water Content (%)	Atterberg Limits	
									LL-PL-PI	Percent Fines
			0.4	11.59						
2		TOPSOIL , 5 inches	2.0				2-2-3-4 N=5			
3		POORLY GRADED SAND WITH SILT (SP-SM) , orange, loose	4.0				4-4-6-4 N=10			
		LEAN CLAY WITH SAND (CL) , gray and orange, stiff	8.0				4-6-8-8 N=14			
		POORLY GRADED SAND WITH SILT (SP-SM) , light tan, medium dense	8.0				10-7-9-9 N=16			
		POORLY GRADED SAND (SP) , gray, medium dense	13.0		▽		9-9-8-7 N=17			
2		CLAYEY SAND (SC) , with shell fragments, dark gray and tannish brown, loose to medium dense	23.0	-11			0-2-3-3 N=5			
		LIMESTONE , tan and dark gray, contains shell fragments	23.0	-11			7-7-4-7 N=11			
							13-12-10-3 N=22			
							11-6-6-6 N=12			
							11-13-9-12 N=22			
3							12-5-7-6 N=12			
							10-5-4-8 N=9			
							11-7-6-10 N=13			
		Boring Terminated at 50 Feet	50.0	-38						

See Exploration and Testing Procedures for a description of field and laboratory procedures used and additional data (If any).
 See Supporting Information for explanation of symbols and abbreviations.

Notes

Elevation Reference: Approximate elevation obtained from Google Earth Pro

Water Level Observations

- While drilling
- After 24 hours

Drill Rig
CME 55

Hammer Type
Automatic

Driller
Tim. D

Logged by
L. West

Boring Started
10-13-2023

Boring Completed
10-13-2023

Advancement Method
Mud Rotary

Abandonment Method
Boring backfilled with soil cuttings upon completion.

Boring Log No. B-5

Model Layer	Graphic Log	Location: See Exploration Plan Latitude: 35.5438° Longitude: -77.0349°	Depth (Ft.)	Elevation: 8 (Ft.) +/-	Water Level Observations	Sample Type	Field Test Results	Water Content (%)	Atterberg Limits	
									LL-PL-PI	Percent Fines
2	0.5	TOPSOIL , 6 inches	7.5				1-2-2-2 N=4			
	4.0	SILTY SAND (SM) , dark brown to grayish brown, very loose to loose	4				1-1-2-6 N=3			
	6.0	POORLY GRADED SAND WITH SILT (SP-SM) , gray, medium dense	2	5			7-11-11-14 N=22			
		POORLY GRADED SAND (SP) , gray, loose to medium dense		10	▽		10-8-5-5 N=13			
				15			2-1-3-3 N=4			
				-5			4-4-4-5 N=8			
	13.0	SILTY SAND (SM) , with shell fragments, tannish brown, loose	-10				9-8-8-5 N=16			
	18.0	CLAYEY SAND (SC) , with shell fragments, light gray, medium dense	-12							
	20.0	Boring Terminated at 20 Feet								

See Exploration and Testing Procedures for a description of field and laboratory procedures used and additional data (If any).
 See Supporting Information for explanation of symbols and abbreviations.

Notes

Elevation Reference: Approximate elevation obtained from Google Earth Pro

Water Level Observations

▽ While drilling

Drill Rig
CME 55

Hammer Type
Automatic

Driller
Tim. D

Logged by
L. West

Boring Started
10-13-2023

Boring Completed
10-13-2023

Advancement Method
Mud Rotary

Abandonment Method
Boring backfilled with soil cuttings upon completion.

Boring Log No. B-6

Model Layer	Graphic Log	Location: See Exploration Plan Latitude: 35.5438° Longitude: -77.0349°	Depth (Ft.)	Elevation: 8 (Ft.) +/-	Water Level Observations	Sample Type	Field Test Results	Water Content (%)	Atterberg Limits	
									LL-PL-PI	Percent Fines
		Depth (Ft.)								
		0.5 TOPSOIL , 6 inches	0.5	7.5			2-2-2-2 N=4			
		SILTY SAND (SM) , dark brown, loose					2-2-3-1 N=5			
		4.0 POORLY GRADED SAND (SP) , gray, loose	4.0				3-3-5-4 N=8			
					▽		2-2-3-1 N=5			
		8.0 CLAYEY SAND (SC) , with shell fragments, dark gray, very loose to medium dense	8.0	0			1-1-2-2 N=3			
2										
							4-5-6-8 N=11			
		18.0 SILTY SAND (SM) , with shell fragments, grayish tan, loose	18.0	-10			6-4-1-4 N=5			
		Boring Terminated at 20 Feet	20.0	-12						

See Exploration and Testing Procedures for a description of field and laboratory procedures used and additional data (If any).
 See Supporting Information for explanation of symbols and abbreviations.

Notes
 Elevation Reference: Approximate elevation obtained from Google Earth Pro

Water Level Observations
 ▽ While drilling

Advancement Method
 Mud Rotary

Abandonment Method
 Boring backfilled with soil cuttings upon completion.

Drill Rig
 CME 55
Hammer Type
 Automatic
Driller
 Tim. D
Logged by
 L. West
Boring Started
 10-13-2023
Boring Completed
 10-13-2023

Boring Log No. B-7

Model Layer	Graphic Log	Location: See Exploration Plan Latitude: 35.5438° Longitude: -77.0349°	Depth (Ft.)	Elevation: 8 (Ft.) +/-	Water Level Observations	Sample Type	Field Test Results	Water Content (%)	Atterberg Limits	
									LL-PL-PI	Percent Fines
		Depth (Ft.)								
		0.6 TOPSOIL , 7 inches	7.42				2-3-2-3 N=5			
		2.0 SILTY SAND (SM) , dark brown, loose	6				4-4-4-5 N=8			
		POORLY GRADED SAND WITH SILT (SP-SM) , gray and tan, loose	4				5-5-4-5 N=9			
		POORLY GRADED SAND (SP) , gray, very loose to medium dense			▽		4-7-7-6 N=14			
							1-1-1-1 N=2			
		13.0 CLAYEY SAND (SC) , with shell fragments, dark gray, medium dense	-5				3-4-7-11 N=11			
		18.0 SILTY SAND (SM) , with shell fragments, gray, medium dense	-10				12-10-10-9 N=20			
		20.0 Boring Terminated at 20 Feet	-12							

See **Exploration and Testing Procedures** for a description of field and laboratory procedures used and additional data (If any).
 See **Supporting Information** for explanation of symbols and abbreviations.

Notes

Elevation Reference: Approximate elevation obtained from Google Earth Pro

Water Level Observations

▽ While drilling

Drill Rig
CME 55

Hammer Type
Automatic

Driller
Tim. D

Logged by
L. West

Boring Started
10-13-2023

Boring Completed
10-13-2023

Advancement Method
Mud Rotary

Abandonment Method
Boring backfilled with soil cuttings upon completion.

Boring Log No. B-8

Model Layer	Graphic Log	Location: See Exploration Plan Latitude: 35.5438° Longitude: -77.0349°	Depth (Ft.)	Elevation: 9 (Ft.) +/-	Water Level Observations	Sample Type	Field Test Results	Water Content (%)	Atterberg Limits	
									LL-PL-PI	Percent Fines
		Depth (Ft.)	0.3	8.67						
		TOPSOIL , 4 inches	2.0	7			1-2-3-3 N=5	7.9		
		POORLY GRADED SAND WITH SILT (SP-SM) , dark brown and tannish brown, loose					2-1-1-1 N=2	27.0		
		CLAYEY SAND (SC) , dark brown and light gray, very loose to loose					1-1-1-1 N=2	21.5	25-13-12	41
							1-1-2-2 N=3	20.1		
							2-2-3-3 N=5	19.6		
		SILTY SAND (SM) , with shell fragments, orange and gray, medium dense	13.0	-4			5-5-6-6 N=11	32.2		
							4-4-7-7 N=11	26.3		
		Boring Terminated at 20 Feet	20.0	-11						

See Exploration and Testing Procedures for a description of field and laboratory procedures used and additional data (If any).
 See Supporting Information for explanation of symbols and abbreviations.

Notes

Elevation Reference: Approximate elevation obtained from Google Earth Pro

Water Level Observations

Water level not determined

Drill Rig

CME 55

Hammer Type

Automatic

Driller

Tim. D

Logged by

L. West

Advancement Method

Mud Rotary

Abandonment Method

Boring backfilled with soil cuttings upon completion.

Boring Started

10-13-2023

Boring Completed

10-13-2023

Boring Log No. B-9

Model Layer	Graphic Log	Location: See Exploration Plan Latitude: 35.5438° Longitude: -77.0349° Depth (Ft.) Elevation: 10 (Ft.) +/-	Depth (Ft.)	Water Level Observations	Sample Type	Field Test Results	Water Content (%)	Atterberg Limits	
								LL-PL-PI	Percent Fines
	0.6	TOPSOIL , 7 inches	9.42			1-2-2-2 N=4			
	6.0	POORLY GRADED SAND WITH SILT (SP-SM) , tannish brown and gray, very loose to loose	4	▽		2-1-2-1 N=3			
	6.0	POORLY GRADED SAND (SP) , gray and light tan, very loose to loose	4			1-2-1-2 N=3			
	13.0	CLAYEY SAND (SC) , with shell fragments, dark gray, gray and orangish brown, loose to medium dense	-3			2-2-1-1 N=3			
	13.0		-3			2-2-2-3 N=4			
	20.0		-10			4-4-5-5 N=9			
	20.0	Boring Terminated at 20 Feet	-10			10-11-10-11 N=21			

<p>See Exploration and Testing Procedures for a description of field and laboratory procedures used and additional data (If any). See Supporting Information for explanation of symbols and abbreviations.</p> <p>Notes Elevation Reference: Approximate elevation obtained from Google Earth Pro</p>	<p>Water Level Observations ▽ While drilling</p> <p>Advancement Method Mud Rotary</p> <p>Abandonment Method Boring backfilled with soil cuttings upon completion.</p>	<p>Drill Rig CME 55</p> <p>Hammer Type Automatic</p> <p>Driller Tim. D</p> <p>Logged by L. West</p> <p>Boring Started 10-13-2023</p> <p>Boring Completed 10-13-2023</p>
--	---	---

Boring Log No. B-10

Model Layer	Graphic Log	Location: See Exploration Plan Latitude: 35.5438° Longitude: -77.0349°	Depth (Ft.)	Elevation: 15 (Ft.) +/-	Water Level Observations	Sample Type	Field Test Results	Water Content (%)	Atterberg Limits	
									LL-PL-PI	Percent Fines
		Depth (Ft.)								
		0.7		14.33						
		TOPSOIL , 8 inches					1-2-2-3 N=4			
		POORLY GRADED SAND WITH SILT (SP-SM) , brown to tannish brown, loose					1-2-3-2 N=5			
		4.0		11			2-1-1-1 N=2			
		SILTY SAND (SM) , light tan, very loose					1-1-1-2 N=2			
		6.0		9			3-3-5-6 N=8			
		CLAYEY SAND (SC) , gray and orange, very loose to loose, clay lense noted at 7 feet								
2		13.0		2						
		POORLY GRADED SAND WITH SILT (SP-SM) , light tan, loose					7-6-3-2 N=9			
		18.0		-3						
3		SANDY LEAN CLAY (CL) , with shell fragments, dark gray, medium stiff					5-4-3-3 N=7			
		20.0		-5						
		Boring Terminated at 20 Feet								

See Exploration and Testing Procedures for a description of field and laboratory procedures used and additional data (If any).
 See Supporting Information for explanation of symbols and abbreviations.

Notes
 Elevation Reference: Approximate elevation obtained from Google Earth Pro

Water Level Observations
 Water level not determined

Advancement Method
 Mud Rotary

Abandonment Method
 Boring backfilled with soil cuttings upon completion.

Drill Rig
 CME 55
Hammer Type
 Automatic
Driller
 Tim. D
Logged by
 L. West
Boring Started
 10-13-2023
Boring Completed
 10-13-2023

Boring Log No. B-11

Model Layer	Graphic Log	Location: See Exploration Plan Latitude: 35.5438° Longitude: -77.0349°	Depth (Ft.)	Elevation: 16 (Ft.) +/-	Water Level Observations	Sample Type	Field Test Results	Water Content (%)	Atterberg Limits	
									LL-PL-PI	Percent Fines
		Depth (Ft.)								
		0.3 TOPSOIL , 4 inches	15.67				2-3-3-3 N=6			
2		POORLY GRADED SAND WITH SILT (SP-SM) , tannish brown, loose	14				1-1-2-1 N=3			
		SILTY SAND (SM) , orange and light tan, very loose to loose					1-2-2-2 N=4			
							1-2-1-2 N=3			
3		SANDY LEAN CLAY (CL) , gray, medium stiff	8		▽		1-2-3-4 N=5			
		POORLY GRADED SAND (SP) , light tan, medium dense	3				11-13-9-9 N=22			
2		CLAYEY SAND (SC) , with shell fragments, dark gray and orange, loose	18.0				2-2-4-4 N=6			
		Boring Terminated at 20 Feet	20.0							

See **Exploration and Testing Procedures** for a description of field and laboratory procedures used and additional data (If any).
 See **Supporting Information** for explanation of symbols and abbreviations.

Notes

Elevation Reference: Approximate elevation obtained from Google Earth Pro

Water Level Observations

▽ While drilling

Drill Rig
CME 55

Hammer Type
Automatic

Driller
Tim. D

Logged by
L. West

Boring Started
10-13-2023

Boring Completed
10-13-2023

Advancement Method

Mud Rotary

Abandonment Method

Boring backfilled with soil cuttings upon completion.

Boring Log No. B-12

Model Layer	Graphic Log	Location: See Exploration Plan Latitude: 35.5438° Longitude: -77.0349° Depth (Ft.) Elevation: 16 (Ft.) +/-	Depth (Ft.)	Water Level Observations	Sample Type	Field Test Results	Water Content (%)	Atterberg Limits	
								LL-PL-PI	Percent Fines
		0.5 TOPSOIL , 6 inches	15.5			2-3-2-4 N=5			
		POORLY GRADED SAND WITH SILT (SP-SM) , tannish brown to tan and gray, very loose to loose				2-2-2-1 N=4			
			5			2-1-2-2 N=3			
						2-3-3-3 N=6			
			10	▽		2-1-3-3 N=4			
		13.0	3			3-4-5-8 N=9			
		SILTY SAND (SM) , gray and orange, loose, clay lense noted from 13 feet to 14 feet	15						
		18.0	-2			2-2-1-2 N=3			
		POORLY GRADED SAND (SP) , light tan and orange, very loose	20						
		20.0	-4						
		Boring Terminated at 20 Feet							

See Exploration and Testing Procedures for a description of field and laboratory procedures used and additional data (If any).
 See Supporting Information for explanation of symbols and abbreviations.

Notes
 Elevation Reference: Approximate elevation obtained from Google Earth Pro

Water Level Observations
 ▽ While drilling

Advancement Method
 Mud Rotary

Abandonment Method
 Boring backfilled with soil cuttings upon completion.

Drill Rig
 CME 55
Hammer Type
 Automatic
Driller
 Tim. D
Logged by
 L. West
Boring Started
 10-12-2023
Boring Completed
 10-12-2023

Boring Log No. B-13

Model Layer	Graphic Log	Location: See Exploration Plan Latitude: 35.5438° Longitude: -77.0349°	Depth (Ft.)	Elevation: 17 (Ft.) +/-	Water Level Observations	Sample Type	Field Test Results	Water Content (%)	Atterberg Limits	
									LL-PL-PI	Percent Fines
		Depth (Ft.)								
		0.4 TOPSOIL , 5 inches	16.58				2-2-2-3 N=4			
		2.0 SILTY SAND (SM) , dark brown, loose	15				2-2-2-2 N=4			
		POORLY GRADED SAND WITH SILT (SP-SM) , tan to light tan and orange, very loose to loose					1-1-1-2 N=2			
							1-2-2-3 N=4			
		8.0 SILTY SAND (SM) , orange and light gray, loose	9		▽		2-2-2-2 N=4			
		13.0 POORLY GRADED SAND WITH SILT (SP-SM) , orange, medium dense	4				4-7-10-11 N=17			
		18.0 CLAYEY SAND (SC) , with shell fragments, reddish brown, loose	-1				1-2-2-3 N=4			
		20.0 Boring Terminated at 20 Feet	-3							

<p>See Exploration and Testing Procedures for a description of field and laboratory procedures used and additional data (If any). See Supporting Information for explanation of symbols and abbreviations.</p> <p>Notes Elevation Reference: Approximate elevation obtained from Google Earth Pro</p>	<p>Water Level Observations ▽ While drilling</p> <p>Advancement Method Mud Rotary</p> <p>Abandonment Method Boring backfilled with soil cuttings upon completion.</p>	<p>Drill Rig CME 55</p> <p>Hammer Type Automatic</p> <p>Driller Tim. D</p> <p>Logged by L. West</p> <p>Boring Started 10-12-2023</p> <p>Boring Completed 10-12-2023</p>
--	---	---

Boring Log No. B-14

Model Layer	Graphic Log	Location: See Exploration Plan Latitude: 35.5438° Longitude: -77.0349°	Depth (Ft.)	Elevation: 18 (Ft.) +/-	Water Level Observations	Sample Type	Field Test Results	Water Content (%)	Atterberg Limits	
									LL-PL-PI	Percent Fines
		Depth (Ft.)								
	17.5	0.5 TOPSOIL , 6 inches	17.5				3-5-2-2 N=7			
	16	2.0 CLAYEY SAND (SC) , orangish brown, loose	16				3-3-2-2 N=5			
	14	SILTY SAND (SM) , tan and orangish brown, loose	14				3-2-2-2 N=4			
	5	POORLY GRADED SAND WITH SILT (SP-SM) , tan and orangish brown, loose	5				3-3-3-3 N=6			
	10		10		▽		3-4-5-5 N=9			
	15	13.0 SILTY SAND (SM) , orange and tan, medium dense	13.0				9-10-9-8 N=19			
	0	18.0 POORLY GRADED SAND (SP) , light tan and gray, loose	18.0				6-3-3-3 N=6			
	-2	20.0 Boring Terminated at 20 Feet	20.0							

See **Exploration and Testing Procedures** for a description of field and laboratory procedures used and additional data (If any).
 See **Supporting Information** for explanation of symbols and abbreviations.

Notes

Elevation Reference: Approximate elevation obtained from Google Earth Pro

Water Level Observations

▽ While drilling

Drill Rig
CME 55

Hammer Type
Automatic

Driller
Tim. D

Logged by
L. West

Boring Started
10-12-2023

Boring Completed
10-12-2023

Advancement Method
Mud Rotary

Abandonment Method
Boring backfilled with soil cuttings upon completion.

Boring Log No. B-15

Model Layer	Graphic Log	Location: See Exploration Plan Latitude: 35.5438° Longitude: -77.0349°	Depth (Ft.)	Elevation: 12 (Ft.) +/-	Water Level Observations	Sample Type	Field Test Results	Water Content (%)	Atterberg Limits	
									LL-PL-PI	Percent Fines
3		0.3 / TOPSOIL , 3 inches	0.3	11.75			4-3-3-3 N=6	24.6		
		LEAN CLAY WITH SAND (CL) , gray and orange, medium stiff to stiff	4.0	8			3-4-4-4 N=8	31.8		
2		SILTY SAND (SM) , orange, gray and light tan, medium dense	5		▽		6-6-8-8 N=14			
			7-12-12-12 N=24							
			6-9-6-4 N=15	10						
		CLAYEY SAND (SC) , gray, very loose	13.0	-1			1-1-1-1 N=2			
		POORLY GRADED SAND WITH SILT (SP-SM) , dark gray, loose	18.0	-6			4-4-5-4 N=9			
		Boring Terminated at 20 Feet	20.0	-8						

<p>See Exploration and Testing Procedures for a description of field and laboratory procedures used and additional data (If any).</p> <p>See Supporting Information for explanation of symbols and abbreviations.</p>	<p>Water Level Observations</p> <p>▽ While drilling</p>	<p>Drill Rig CME 55</p> <p>Hammer Type Automatic</p> <p>Driller Tim. D</p> <p>Logged by L. West</p> <p>Boring Started 10-14-2023</p> <p>Boring Completed 10-14-2023</p>
<p>Notes</p> <p>Elevation Reference: Approximate elevation obtained from Google Earth Pro</p>	<p>Advancement Method Mud Rotary</p> <p>Abandonment Method Boring backfilled with soil cuttings upon completion.</p>	

Boring Log No. B-P1

Model Layer	Graphic Log	Location: See Exploration Plan Latitude: 35.5438° Longitude: -77.0349°	Depth (Ft.)	Water Level Observations	Sample Type	Field Test Results	Water Content (%)	Atterberg Limits	
								LL-PL-PI	Percent Fines
		Depth (Ft.) Elevation: 9 (Ft.) +/-							
		0.4 TOPSOIL , 5 inches	8.58			2-2-1-2 N=3			
2		POORLY GRADED SAND WITH SILT (SP-SM) , grayish brown and light tan, very loose to loose	5			3-2-2-2 N=4			
		POORLY GRADED SAND (SP) , light tan, loose	3	▽		2-2-3-2 N=5			
		Boring Terminated at 6 Feet							

<p>See Exploration and Testing Procedures for a description of field and laboratory procedures used and additional data (If any).</p> <p>See Supporting Information for explanation of symbols and abbreviations.</p> <p>Notes Elevation Reference: Approximate elevation obtained from Google Earth Pro</p>	<p>Water Level Observations ▽ While drilling</p> <p>Advancement Method Sampler</p> <p>Abandonment Method Boring backfilled with soil cuttings upon completion.</p>	<p>Drill Rig CME 55</p> <p>Hammer Type Automatic</p> <p>Driller Tim. D</p> <p>Logged by L. West</p> <p>Boring Started 10-13-2023</p> <p>Boring Completed 10-13-2023</p>
---	---	---

Boring Log No. B-P2

Model Layer	Graphic Log	Location: See Exploration Plan Latitude: 35.5438° Longitude: -77.0349°	Depth (Ft.)	Elevation: 6 (Ft.) +/-	Water Level Observations	Sample Type	Field Test Results	Water Content (%)	Atterberg Limits	
									LL-PL-PI	Percent Fines
		Depth (Ft.)								
		0.4 TOPSOIL , 5 inches	5.58				2-3-4-5 N=7			
2		2.0 POORLY GRADED SAND WITH SILT (SP-SM) , gray, loose	4		▽		4-4-4-2 N=8			
		4.0 POORLY GRADED SAND (SP) , light gray, loose	2				1-1-1-1 N=2			
		6.0 CLAYEY SAND (SC) , gray to dark gray, very loose	0							
Boring Terminated at 6 Feet										

See **Exploration and Testing Procedures** for a description of field and laboratory procedures used and additional data (If any).
 See **Supporting Information** for explanation of symbols and abbreviations.

Notes
 Elevation Reference: Approximate elevation obtained from Google Earth Pro

Water Level Observations
 ▽ While drilling

Advancement Method
 Sampler

Abandonment Method
 Boring backfilled with soil cuttings upon completion.

Drill Rig
 CME 55
Hammer Type
 Automatic
Driller
 Tim. D
Logged by
 L. West
Boring Started
 10-13-2023
Boring Completed
 10-13-2023

Boring Log No. B-P3

Model Layer	Graphic Log	Location: See Exploration Plan Latitude: 35.5438° Longitude: -77.0349°	Depth (Ft.)	Water Level Observations	Sample Type	Field Test Results	Water Content (%)	Atterberg Limits	
								LL-PL-PI	Percent Fines
		Depth (Ft.) Elevation: 4 (Ft.) +/-							
	TOPSOIL, 5 inches	0.4	3.58			3-3-6-4 N=9	15.9		
2	SILTY SAND (SM), light gray, loose	2.0	2			8-2-1-1 N=3			
	POORLY GRADED SAND (SP), light gray, very loose	4.0	0	▽		2-2-2-4 N=4			
	CLAYEY SAND (SC), with shell fragments, dark gray, loose	6.0	-2						
Boring Terminated at 6 Feet									

See Exploration and Testing Procedures for a description of field and laboratory procedures used and additional data (If any).
 See Supporting Information for explanation of symbols and abbreviations.

Notes
 Elevation Reference: Approximate elevation obtained from Google Earth Pro

Water Level Observations
 ▽ While drilling

Advancement Method
 Sampler

Abandonment Method
 Boring backfilled with soil cuttings upon completion.

Drill Rig
 CME 55

Hammer Type
 Automatic

Driller
 Tim. D

Logged by
 L. West

Boring Started
 10-13-2023

Boring Completed
 10-13-2023

Boring Log No. B-P4

Model Layer	Graphic Log	Location: See Exploration Plan Latitude: 35.5438° Longitude: -77.0349°	Depth (Ft.)	Elevation: 7 (Ft.) +/-	Water Level Observations	Sample Type	Field Test Results	Water Content (%)	Atterberg Limits	
									LL-PL-PI	Percent Fines
		TOPSOIL , 17 inches	1.4	5.6						
1		FILL - SILTY SAND , dark brown	2.0	5			1-2-2-2 N=4			
		FILL - SILTY CLAYEY SAND , dark brown	3.0	4			1-2-2-4 N=4			
2		SILTY SAND (SM) , gray, loose	4.0	3	▽					
		POORLY GRADED SAND (SP) , gray, medium dense	6.0	1			7-8-7-4 N=15			
Boring Terminated at 6 Feet										

See **Exploration and Testing Procedures** for a description of field and laboratory procedures used and additional data (If any).
 See **Supporting Information** for explanation of symbols and abbreviations.

Notes

Elevation Reference: Approximate elevation obtained from Google Earth Pro

Water Level Observations

▽ While drilling

Drill Rig
CME 55

Hammer Type
Automatic

Driller
Tim. D

Logged by
L. West

Boring Started
10-13-2023

Boring Completed
10-13-2023

Advancement Method
Sampler

Abandonment Method
Boring backfilled with soil cuttings upon completion.

Boring Log No. B-P5

Model Layer	Graphic Log	Location: See Exploration Plan Latitude: 35.5438° Longitude: -77.0349°	Depth (Ft.)	Water Level Observations	Sample Type	Field Test Results	Water Content (%)	Atterberg Limits	
								LL-PL-PI	Percent Fines
		Depth (Ft.) Elevation: 11 (Ft.) +/-							
	11.5 11.0 10.5 10.0 9.5 9.0 8.5 8.0 7.5 7.0 6.5 6.0	0.5 TOPSOIL , 6 inches	10.5			2-3-2-2 N=5	18.3	23-14-9	49
2		2.0 CLAYEY SAND (SC) , orange and gray, loose	9			2-4-8-7 N=12			
		SILTY SAND (SM) , light gray, medium dense	5			6-7-7-5 N=14			
		Boring Terminated at 6 Feet							

See Exploration and Testing Procedures for a description of field and laboratory procedures used and additional data (If any).
 See Supporting Information for explanation of symbols and abbreviations.

Notes
 Elevation Reference: Approximate elevation obtained from Google Earth Pro

Water Level Observations
 No free water observed

Advancement Method
 Sampler

Abandonment Method
 Boring backfilled with soil cuttings upon completion.

Drill Rig
 CME 55

Hammer Type
 Automatic

Driller
 Tim. D

Logged by
 L. West

Boring Started
 10-12-2023

Boring Completed
 10-12-2023

Boring Log No. B-P6

Model Layer	Graphic Log	Location: See Exploration Plan Latitude: 35.5431° Longitude: -77.0336°	Depth (Ft.)	Elevation: 15 (Ft.) +/-	Water Level Observations	Sample Type	Field Test Results	Water Content (%)	Atterberg Limits	
									LL-PL-PI	Percent Fines
	0.5	TOPSOIL , 6 inches	14.5				2-6-7-7 N=13			
	3.0	FILL - POORLY GRADED SAND WITH SILT , trace debris (glass fragments and rusty nails), dark brown and tannish brown	12				4-3-2-2 N=5			
2	6.0	POORLY GRADED SAND WITH SILT (SP-SM) , dark brown and tannish brown, loose	9				2-3-2-2 N=5			
Boring Terminated at 6 Feet										

See Exploration and Testing Procedures for a description of field and laboratory procedures used and additional data (If any).
 See Supporting Information for explanation of symbols and abbreviations.

Notes
 Elevation Reference: Approximate elevation obtained from Google Earth Pro

Water Level Observations
 No free water observed

Advancement Method
 Sampler

Abandonment Method
 Boring backfilled with soil cuttings upon completion.

Drill Rig
 CME 55

Hammer Type
 Automatic

Driller
 Tim. D

Logged by
 L. West

Boring Started
 10-12-2023

Boring Completed
 10-12-2023

Boring Log No. B-P7

Model Layer	Graphic Log	Location: See Exploration Plan Latitude: 35.5438° Longitude: -77.0349°	Depth (Ft.)	Water Level Observations	Sample Type	Field Test Results	Water Content (%)	Atterberg Limits	
								LL-PL-PI	Percent Fines
		Depth (Ft.) Elevation: 15 (Ft.) +/-							
	0.3	TOPSOIL , 4 inches 14.67				3-4-5-4 N=9			
2	4.0	POORLY GRADED SAND WITH SILT (SP-SM) , tannish brown and orange, loose 11				2-2-3-2 N=5			
	6.0	CLAYEY SAND (SC) , gray, loose 9	5			2-3-3-5 N=6			
Boring Terminated at 6 Feet									

<p>See Exploration and Testing Procedures for a description of field and laboratory procedures used and additional data (If any).</p> <p>See Supporting Information for explanation of symbols and abbreviations.</p>	<p>Water Level Observations No free water observed</p>
<p>Notes Elevation Reference: Approximate elevation obtained from Google Earth Pro</p>	<p>Advancement Method Sampler</p> <p>Abandonment Method Boring backfilled with soil cuttings upon completion.</p>
	<p>Drill Rig CME 55</p> <p>Hammer Type Automatic</p> <p>Driller Tim. D</p> <p>Logged by L. West</p> <p>Boring Started 10-14-2023</p> <p>Boring Completed 10-14-2023</p>

Boring Log No. B-P8

Model Layer	Graphic Log	Location: See Exploration Plan Latitude: 35.5438° Longitude: -77.0349°	Depth (Ft.)	Water Level Observations	Sample Type	Field Test Results	Water Content (%)	Atterberg Limits	
								LL-PL-PI	Percent Fines
		Depth (Ft.) Elevation: 11 (Ft.) +/-							
		0.5 TOPSOIL , 6 inches	10.5			4-5-4-6 N=9			
2		CLAYEY SAND (SC) , gray to dark gray, tan and orange, loose	7			2-2-2-2 N=4	21.1		
		4.0 SILTY SAND (SM) , gray, very loose	5			1-2-1-2 N=3			
		Boring Terminated at 6 Feet							

See Exploration and Testing Procedures for a description of field and laboratory procedures used and additional data (If any).
 See Supporting Information for explanation of symbols and abbreviations.

Notes
 Elevation Reference: Approximate elevation obtained from Google Earth Pro

Water Level Observations
 No free water observed

Advancement Method
 Sampler

Abandonment Method
 Boring backfilled with soil cuttings upon completion.

Drill Rig
 CME 55

Hammer Type
 Automatic



Driller
 Tim. D

Logged by
 L. West

Boring Started
 10-14-2023

Boring Completed
 10-14-2023

Boring Log No. B-P9

Model Layer	Graphic Log	Location: See Exploration Plan		Depth (Ft.)	Water Level Observations	Sample Type	Field Test Results	Water Content (%)	Atterberg Limits	
		Latitude: 35.5438° Longitude: -77.0349°	Elevation: 12 (Ft.) +/-						LL-PL-PI	Percent Fines
		0.4	TOPSOIL , 5 inches	11.58						
2		2.0	POORLY GRADED SAND WITH SILT (SP-SM) , tannish brown, medium dense	10			4-6-5-4 N=11			
3		4.0	SANDY LEAN CLAY (CL) , dark gray, medium stiff	8			4-4-3-4 N=7			
2		6.0	SILTY SAND (SM) , dark grayish brown, loose	6			5-4-4-2 N=8			
Boring Terminated at 6 Feet										

See Exploration and Testing Procedures for a description of field and laboratory procedures used and additional data (If any).
 See Supporting Information for explanation of symbols and abbreviations.

Notes

Elevation Reference: Approximate elevation obtained from Google Earth Pro

Water Level Observations

No free water observed

Drill Rig
CME 55

Hammer Type
Automatic

Driller
Tim. D

Logged by
L. West

Boring Started
10-14-2023

Boring Completed
10-14-2023

Advancement Method
Sampler

Abandonment Method
Boring backfilled with soil cuttings upon completion.

Boring Log No. B-P10

Model Layer	Graphic Log	Location: See Exploration Plan Latitude: 35.5438° Longitude: -77.0349°	Depth (Ft.)	Water Level Observations	Sample Type	Field Test Results	Water Content (%)	Atterberg Limits	Percent Fines
								LL-PL-PI	
		Depth (Ft.) Elevation: 22 (Ft.) +/- 0.2' TOPSOIL , 2 inches 21.83'							
3		SANDY LEAN CLAY (CL) , light gray and orange, medium stiff to stiff	18			3-3-4-6 N=7	14.8	37-16-21	64
2		SILTY SAND (SM) , light gray and orange, medium dense	16	5		5-4-5-8 N=9	24.5		
		6.0' Boring Terminated at 6 Feet				7-9-6-5 N=15	14.6		

<p>See Exploration and Testing Procedures for a description of field and laboratory procedures used and additional data (If any). See Supporting Information for explanation of symbols and abbreviations.</p> <p>Notes Elevation Reference: Approximate elevation obtained from Google Earth Pro</p>	<p>Water Level Observations No free water observed</p> <p>Advancement Method Sampler</p> <p>Abandonment Method Boring backfilled with soil cuttings upon completion.</p>	<p>Drill Rig CME 55</p> <p>Hammer Type Automatic</p> <p>Driller Tim. D</p> <p>Logged by L. West</p> <p>Boring Started 10-14-2023</p> <p>Boring Completed 10-14-2023</p>
--	--	---

Grain Size Distribution

ASTM D422 / ASTM C136

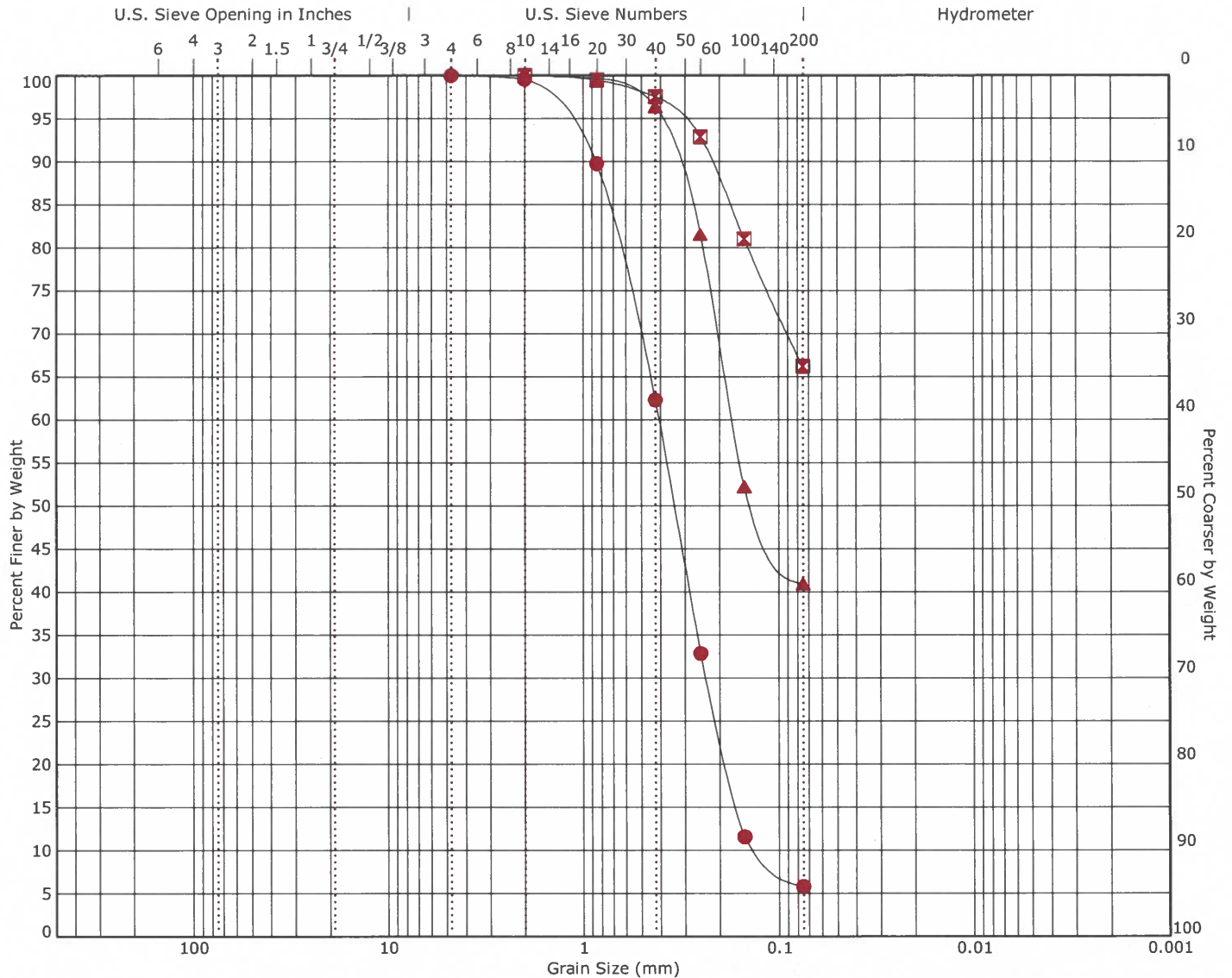

	Cobbles	Gravel		Sand			Silt or Clay		USCS
		coarse	fine	coarse	medium	fine	% Silt	% Clay	
●	B-2	4 - 6	0.0	0.0	94.2	5.8			SP-SM
■	B-4	8 - 10	0.0	0.0	33.8	66.2			CL
▲	B-8	4 - 6	0.0	0.0	59.1	40.9			SC

Description	Grain Size						
	●	■	▲				
● POORLY GRADED SAND with SILT	Sieve	% Finer	Sieve	% Finer	Sieve	% Finer	
■ SANDY LEAN CLAY	#4	100.0	#10	100.0	#10	100.0	D₆₀ 0.408
▲ CLAYEY SAND	#10	99.57	#20	99.48	#20	99.67	D₃₀ 0.233
	#20	89.76	#40	97.55	#40	96.4	D₁₀ 0.124
	#40	62.3	#60	92.89	#60	81.54	
	#60	32.86	#100	81.05	#100	52.24	
	#100	11.58	#200	66.2	#200	40.95	
	#200	5.8					
Remarks	Coefficients						
●	C_c	1.08	■		▲		
■	C_u	3.28					
▲							

Grain Size Distribution

ASTM D422 / ASTM C136

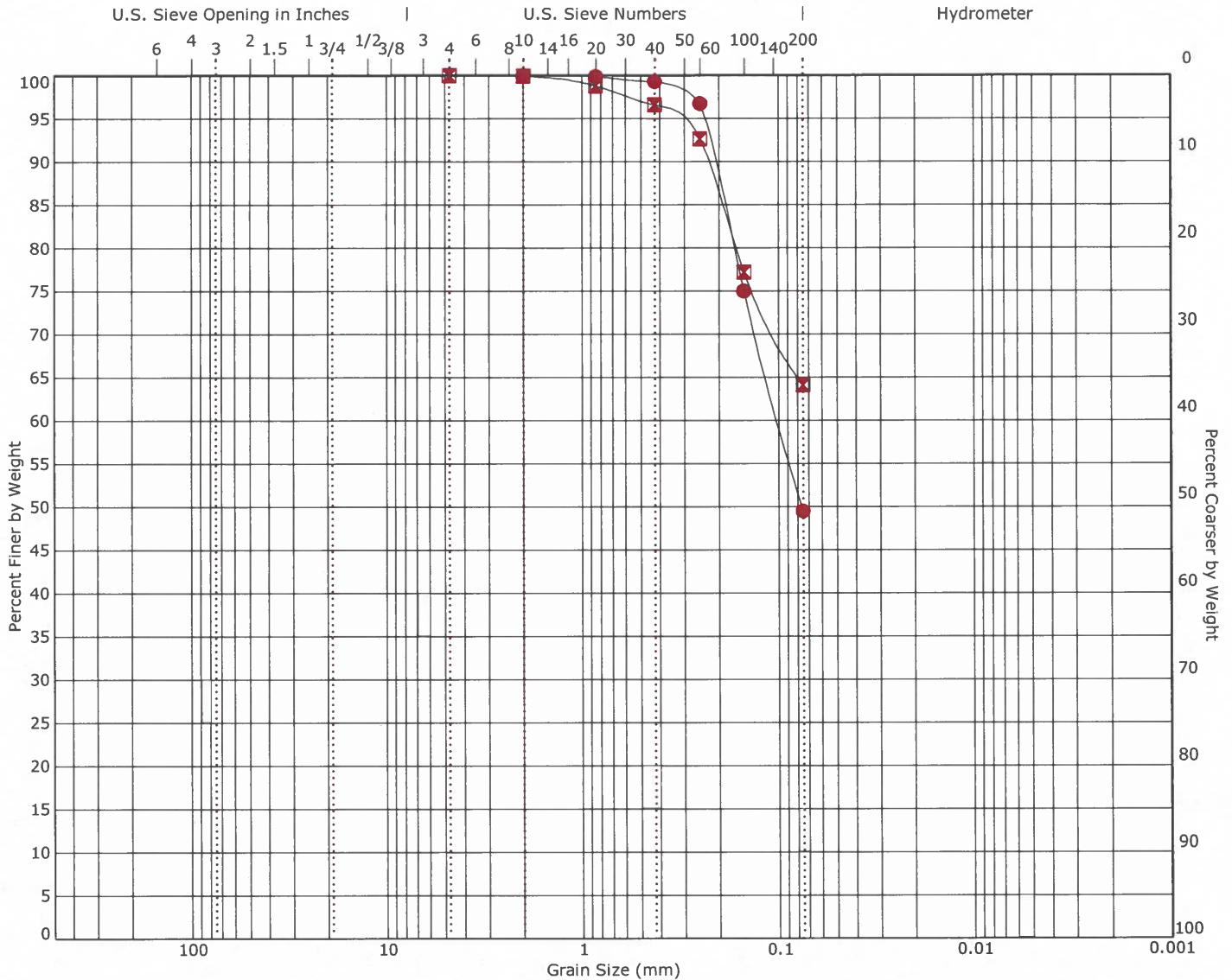

Boring ID	Depth	Gravel			Sand			Silt or Clay		USCS
		coarse	fine	coarse	medium	fine	% Silt	% Clay		
● B-P5	0 - 2	0.0	0.0	50.5		49.5				SC
☒ B-P10	0 - 2	0.0	0.0	35.9		64.1				CL

Description	●		☒		Grain Size	
	Sieve	% Finer	Sieve	% Finer	Sieve	% Finer
● CLAYEY SAND	#10	100.0	#4	100.0		
☒ SANDY LEAN CLAY	#20	99.88	#10	99.91	D ₆₀	0.1
	#40	99.3	#20	98.78	D ₃₀	
	#60	96.73	#40	96.58	D ₁₀	
	#100	74.99	#60	92.61		
	#200	49.49	#100	77.2		
			#200	64.08		

Coefficients		
C _c	●	☒
C _u		

Laboratory tests are not valid if separated from original report.

Atterberg Limit Results

ASTM D4318

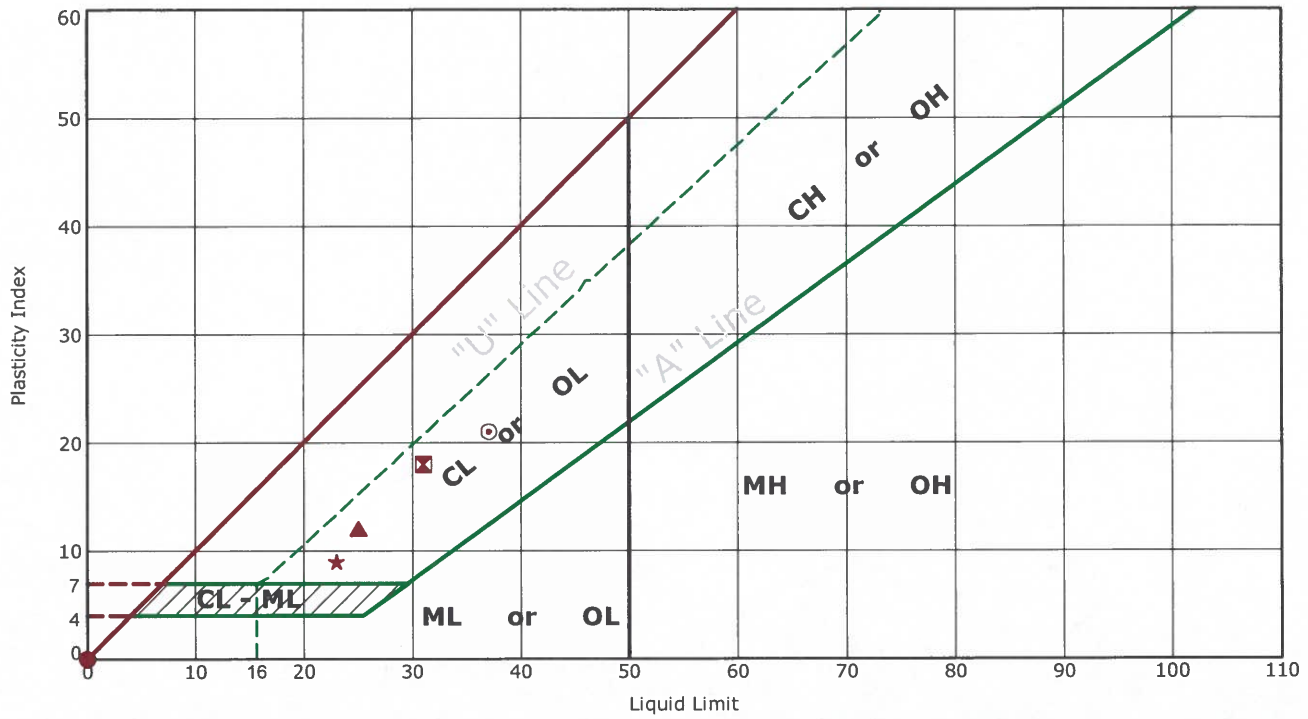

	Boring ID	Depth (Ft)	LL	PL	PI	Fines	USCS	Description
●	B-2	4 - 6	NP	NP	NP	5.8	SP-SM	POORLY GRADED SAND with SILT
⊠	B-4	8 - 10	31	13	18	66.2	CL	SANDY LEAN CLAY
▲	B-8	4 - 6	25	13	12	40.9	SC	CLAYEY SAND
★	B-P5	0 - 2	23	14	9	49.5	SC	CLAYEY SAND
⊙	B-P10	0 - 2	37	16	21	64.1	CL	SANDY LEAN CLAY

Supporting Information

Contents:

General Notes
Unified Soil Classification System
Typical Settlement Plate

Note: All attachments are one page unless noted above.

Unified Soil Classification System

Criteria for Assigning Group Symbols and Group Names Using Laboratory Tests ^A				Soil Classification	
				Group Symbol	Group Name ^B
Coarse-Grained Soils: More than 50% retained on No. 200 sieve	Gravels: More than 50% of coarse fraction retained on No. 4 sieve	Clean Gravels: Less than 5% fines ^C	$Cu \geq 4$ and $1 \leq Cc \leq 3$ ^E	GW	Well-graded gravel ^F
		Gravels with Fines: More than 12% fines ^C	$Cu < 4$ and/or $[Cc < 1$ or $Cc > 3.0]$ ^E	GP	Poorly graded gravel ^F
			Fines classify as ML or MH	GM	Silty gravel ^{F, G, H}
	Sands: 50% or more of coarse fraction passes No. 4 sieve	Clean Sands: Less than 5% fines ^D	Fines classify as CL or CH	GC	Clayey gravel ^{F, G, H}
			$Cu \geq 6$ and $1 \leq Cc \leq 3$ ^E	SW	Well-graded sand ^I
		Sands with Fines: More than 12% fines ^D	$Cu < 6$ and/or $[Cc < 1$ or $Cc > 3.0]$ ^E	SP	Poorly graded sand ^I
Fines classify as ML or MH	SM		Silty sand ^{G, H, I}		
Fine-Grained Soils: 50% or more passes the No. 200 sieve	Silts and Clays: Liquid limit less than 50	Inorganic:	PI > 7 and plots above "A" line ^J	CL	Lean clay ^{K, L, M}
			PI < 4 or plots below "A" line ^J	ML	Silt ^{K, L, M}
		Organic:	$\frac{LL \text{ oven dried}}{LL \text{ not dried}} < 0.75$	OL	Organic clay ^{K, L, M, N} Organic silt ^{K, L, M, O}
	Silts and Clays: Liquid limit 50 or more	Inorganic:	PI plots on or above "A" line	CH	Fat clay ^{K, L, M}
			PI plots below "A" line	MH	Elastic silt ^{K, L, M}
		Organic:	$\frac{LL \text{ oven dried}}{LL \text{ not dried}} < 0.75$	OH	Organic clay ^{K, L, M, P} Organic silt ^{K, L, M, Q}
Highly organic soils:	Primarily organic matter, dark in color, and organic odor			PT	Peat

^A Based on the material passing the 3-inch (75-mm) sieve.

^B If field sample contained cobbles or boulders, or both, add "with cobbles or boulders, or both" to group name.

^C Gravels with 5 to 12% fines require dual symbols: GW-GM well-graded gravel with silt, GW-GC well-graded gravel with clay, GP-GM poorly graded gravel with silt, GP-GC poorly graded gravel with clay.

^D Sands with 5 to 12% fines require dual symbols: SW-SM well-graded sand with silt, SW-SC well-graded sand with clay, SP-SM poorly graded sand with silt, SP-SC poorly graded sand with clay.

^E $Cu = D_{60}/D_{10}$ $Cc = \frac{(D_{30})^2}{D_{10} \times D_{60}}$

^F If soil contains $\geq 15\%$ sand, add "with sand" to group name.

^G If fines classify as CL-ML, use dual symbol GC-GM, or SC-SM.

^H If fines are organic, add "with organic fines" to group name.

^I If soil contains $\geq 15\%$ gravel, add "with gravel" to group name.

^J If Atterberg limits plot in shaded area, soil is a CL-ML, silty clay.

^K If soil contains 15 to 29% plus No. 200, add "with sand" or "with gravel," whichever is predominant.

^L If soil contains $\geq 30\%$ plus No. 200 predominantly sand, add "sandy" to group name.

^M If soil contains $\geq 30\%$ plus No. 200, predominantly gravel, add "gravelly" to group name.

^N PI ≥ 4 and plots on or above "A" line.

^O PI < 4 or plots below "A" line.

^P PI plots on or above "A" line.

^Q PI plots below "A" line.

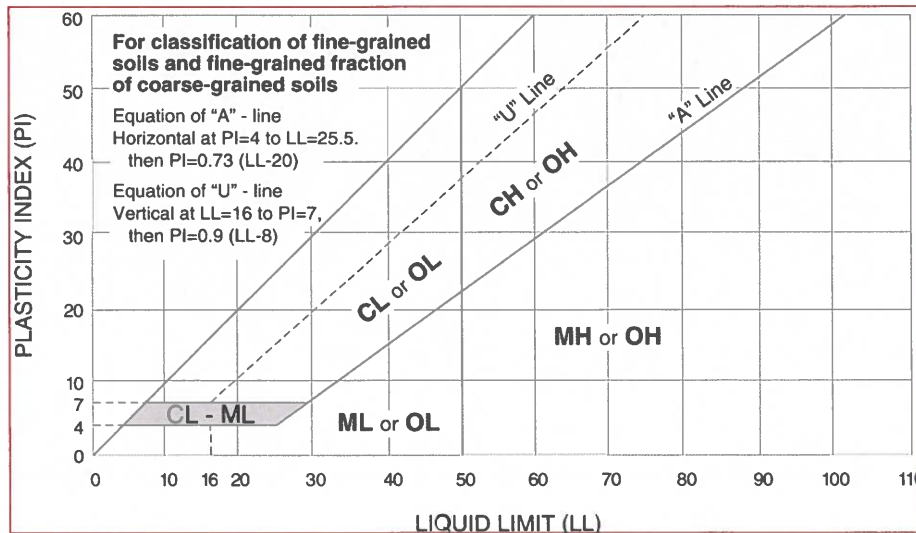

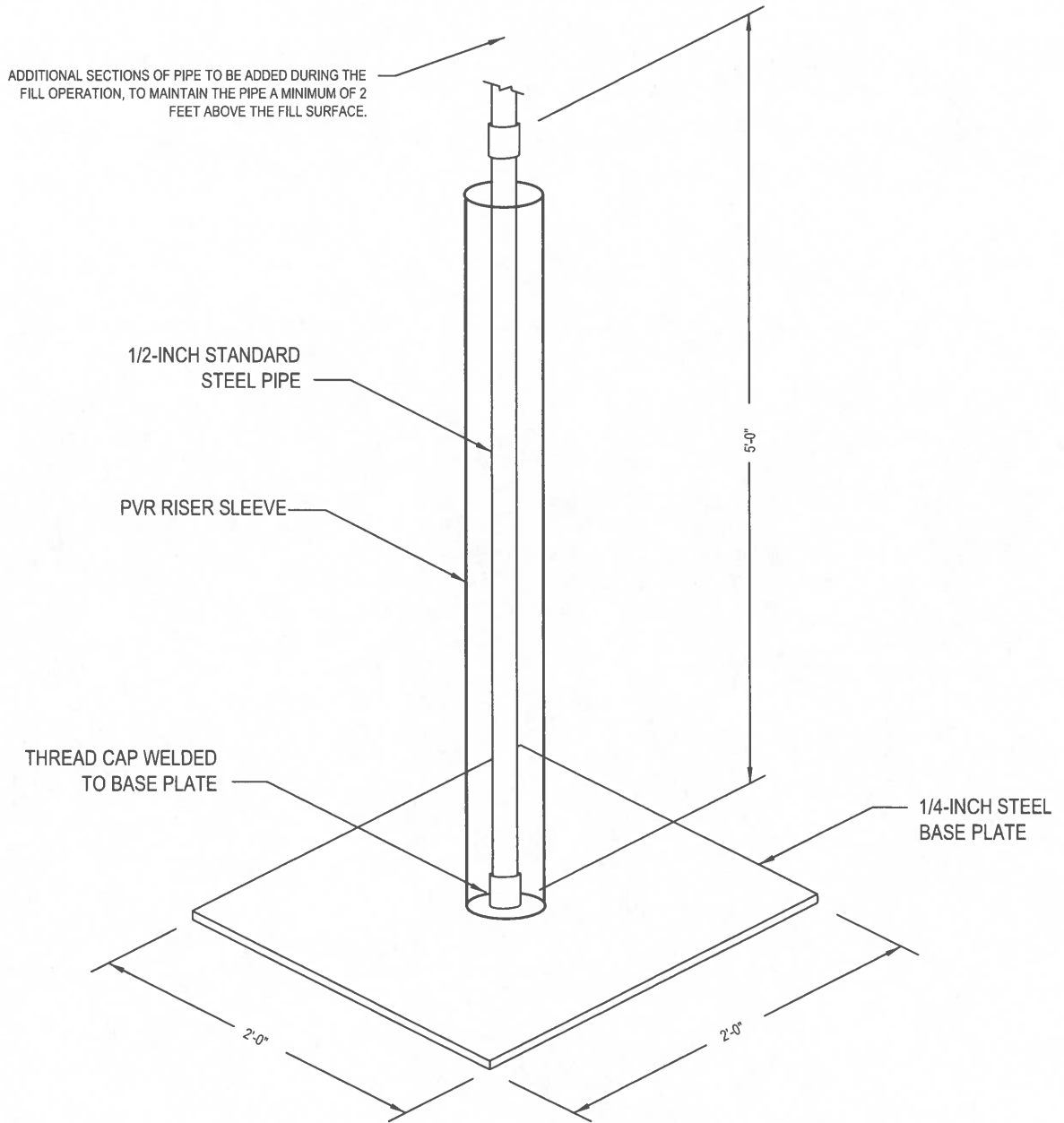

NOTES:

1. A 2-INCH-DIAMETER PVC SLEEVE SHALL BE PLACED AROUND THE VERTICAL METAL PIPE AND ADDED SECTIONS.
2. THE BASE PLATE SHALL BE PLACED PRIOR TO FILL PLACEMENT. A SAND PAD SHALL BE USED IF THE SURFACE IS NOT LEVEL.
3. THE PLATE, VERTICAL PIPE, AND PVC RISER SLEEVE SHALL BE PROTECTED BY BARRICADES OR OTHER DEVICES. DAMAGED OR DISTURBED SETTLEMENT PLATES AND PIPES SHALL BE REPLACED IMMEDIATELY BY INSTALLING A NEW PLATE IN THE SAME AREA AS RECOMMENDED BY THE GEOTECHNICAL ENGINEER.

THIS DIAGRAM IS FOR GENERAL LOCATION ONLY, AND IS NOT INTENDED FOR CONSTRUCTION PURPOSES

NOT TO SCALE

Project Mngr: AJG	Project No. 72235092	 314 Beacon Drive Winterville, NC 28590 (252) 353-1600 (252) 353-0002	TYPICAL SETTLEMENT PLATE	FIG. No.
Drawn By: AJG	Scale: AS SHOWN		Geotechnical Engineering Report Eastern Elementary Washington, NC	SP
Checked By: AAN	File No.			
Approved By: AAN	Date: 11/17/23			

RELATED DOCUMENTS:

Drawings and general provisions of Contract, including General and Supplementary Conditions and Division-1 Specification sections, apply to work of this section.

PART 1: GENERAL

Testing laboratory services will be paid for under the cash allowance as indicated in Section 01056 Allowances, to be provided in the General Contractor's bid, as amended below.

DESCRIPTION:

Work Included: From time to time during progress of the work, the Architect may require that testing be performed to determine that materials provided for the work meet the specified requirements; such testing includes, but not necessarily limited to:

- Proofrolling, Cutting & Filling of Soils Remediation Operations
- Soil Compaction
- Cast-In-Place Concrete & Reinforcing
- Structural Steel & Decking Connections
- Masonry Reinforcing
- Exterior Wall Light Gauge Framing
- Fireproofing

Related work described elsewhere: Requirements for testing may be described in various sections of these specifications and Drawings; where no testing requirements are described but the Architect decides that testing is required, the Architect may require testing to be performed under current pertinent standards for testing.

Work not included: Selection of testing laboratory: The Owner will select a pre-qualified independent testing laboratory and / or consultant.

QUALITY ASSURANCE:

Qualifications of testing laboratory: The testing laboratory will be qualified to the Architect's approval in accordance with ASTM E-329-70 "Recommended Practice for Inspection and Testing Agencies for Concrete and Steel Used in Construction".

Codes and Standards: Testing, when required, will be in accordance with all pertinent codes and regulations and with selected standards of the American Society for Testing and Materials.

PRODUCT HANDLING:

Promptly process and distribute all required copies of test reports and related instructions to ensure all necessary retesting and/or replacement of materials with the least possible delay in progress of the work.

PART 2: PRODUCTS

PAYMENT FOR TESTING SERVICES:

Initial Services: All initial testing services shall be paid for by the Owner.

Retesting: When initial tests indicate non-compliance with the contract documents, all subsequent retesting occasioned by the non-compliance shall be performed by the same testing laboratory and the costs thereof will be paid for by the Contractor and not charged to the Owner for Testing.

PART 3: EXECUTION

COOPERATION WITH TESTING LABORATORY:

Representatives of the testing laboratory shall have access to the work at all times; provide facilities for such access in order that the laboratory may properly perform its function.

SCHEDULES FOR TESTING:

Establishing Schedule: By advance discussion with the testing laboratory selected by the Owner, determine the time required for the laboratory to perform its tests and to issue each of its finding.

Provide all required testing time within the construction schedule.

Revising Schedule: When changes of construction schedule are necessary during construction coordinate all such changes of schedule with the testing laboratory as required.

Adherence to Schedule: When the testing laboratory is ready to test according to the determined schedule but is prevented from testing or taking specimens due to incompleteness of work, all extra costs for testing attributable to the delay may be back-charged to the Contractor and shall not be charged to the Owner.

END OF SECTION

RELATED DOCUMENTS:

The general provisions of the Contract, including General and Supplementary Conditions, and General Requirements, and Division 1 specifications that apply to the work specified in this Section.

GENERAL

DESCRIPTION OF WORK:

Work of this Section shall be to provide a Project Sign for each site to be purchased by the Contractor with the project cash allowance specified in 01056, constructed and painted as indicated, and erected on the site in a location selected by the Architect. The project sign shall be maintained by the Contractor until completion of the Project, and repaired and/or relocated as required during the construction period. No other signs will be allowed on the site - the General Contractor will be responsible for enforcing this provision.

END OF SECTION

ABBREVIATIONS AND NAMES: The following acronyms or abbreviations as referenced in contract documents are defined to mean the associated names. Both names and addresses are subject to change, and are believed to be, but are not assured to be, accurate and up-to-date as of date of contract documents:

AA	Aluminum Association 818 Connecticut Ave. NW; Washington DC 20006; 202/862-5100
AAMA	Architectural Aluminum Manufacturers Association 35 E. Southern Bldg.; Washington DC 20005; 202/737-4060
AAN	American Association of Nurserymen 230 Southern Bldg.; Washington, DC 20005; 202/737-4060
AASHTO	American Association of State Highway and Transportation Officials 444 North Capital St.; Washington DC 20001; 202/624-5800
AATCC	American Association of Textile Chemists and Colorists P. O. Box 12215; Research Triangle Park, NC 27709; 919/549-8141
ACI	American Concrete Institute P. O. Box 19150; Detroit, MI 48219; 313/532-2600
ACIL	American Council of Independent Laboratories 1725 K St., NW; Washington DC 20006 202/659-3766
ADC	Air Diffusion Council 230 N. Michigan Aven.; Chicago, IL 60601; 312/372-9800
AGA	American Gas Association 1515 Wilson Blvd., Arlington, VA 22209; 703/841-8400
AHAM	Association of Home Appliance Manufacturers 20 N. Wacker Dr.; Chicago, IL 60606 312/984-5800
AI	Asphalt Institute Asphalt Inst. Bldg.; College Park, MD 20740 301/277-4258
AIA	American Institute of Architects 1735 New York Ave., NW; Washington, DC 20006; 202/626-7474
A.I.A.	American Insurance Association 85 John St.; New York, NY 10038;

	212/699-0400
AISC	American Institute of Steel Construction 400 N. Michigan Ave.; Chicago, IL 60611; 312/670-2400
AISI	American Iron and Steel Institute 1000 16th St., NW; Washington, DC 20036; 202/452-7100
AITC	American Institute of Timber Construction 333 W. Hampden Ave.; Englewood, CO 80110; 303/761-3212
AMCA	Air Movement and Control Association 30 W. University Dr.; Arlington Heights, IL 60004; 312/394-0150
ANSI	American National Standards Institute 1430 Broadway; New York, NY 10018; 212/354-3300
APA	American Plywood Association P. O. Box 11700; Tacoma, WA 98411; 206/565-6600
ARI	Air Conditioning and Refrigeration Institute 1815 N. Fort Myer Dr.; Arlington, VA 22209; 703/524-8800
ASC	Adhesive and Sealant Council 1600 Wilson Blvd.; Arlington, VA 22209; 703/841-1112
ASHRAE	American Society of Heating, Refrigerating and Air-Conditioning Engineers 1791 Tullie Circle, NE; Atlanta, Ga 30329 404/636-8400
ASME	American Society of Mechanical Engineers 345 East 47th St.; New York, NY 10017; 212/705-7722
ASPE	American Society of Plumbing Engineers 15233 Ventura Blvd.; Sherman Oaks, Ca. 91403 213/783-4845
ASSE	American Society of Sanitary Engineering P. O. Box 9712; Bay Village, OH 44140 216/835-3040
ASTM	American Society for Testing and Materials 1916 Race St.; Philadelphia, CA 19103 215/299-5400

AWI	Architectural Woodwork Institute 2310 S. Walter Reed Dr.; Arlington, VA 22206 703/671-9100
AWPA	American Wood-Preserver's Association 7735 Old Georgetown Rd.; Bethesda, MD 20814 301/652-3109
AWPB	American Wood Preservers Bureau P. O. Box 6085; Arlington, VA 22206 703/931-8180
AWS	American Welding Society P. O. Box 351040; Miami, FL 33135 305/642-7090
AWWA	American Water Works Association 6666 W. Quincy Ave., Denver, CO 80235 303/794-7711
BHMA	Builders' Hardware Manufacturers Association (c/o TGAM) 60 East 42nd St.; New York, NY 10017 212/682-8142
BIA	Brick Institute of America 1750 Old Meadow Rd.; McLean, VA. 22102 703/893-4010
CDA	Copper Development Association 405 Lexington Ave.; New York, NY 10174 212/953-7300
CE	Corps of Engineers (U.S. Dept. of the Army) Washington, DC 20314
CFR	Code of Federal Regulations Available from Government Printing Office; Washington, DC 20402 (usually first published in Federal Register)
CISPI	Cast Iron Soil Pipe Institute 1499 Chain Bridge Rd., McLean, VA. 22101 703/827-9177
CRIGLP	CRI Green Label Plus 730 College Drive Dalton, GA 30720 706-278-3176
CRSI	Concrete Reinforcing Steel Institute 933 Plum Grove Rd., Schamburg, IL 60195 312/372-5059
CS	Commercial Standard of NBS (U.S. Dept. of Commerce)

	Government Printing Office; Washington, DC 20402
DHI	Door and Hardware Institute 7711 Old Springhouse Rd., McLean, VA. 22102 703/556-3990
EIA	Electronic Industries Association 2001 Eye St., NW; Washington, DC 20006 202/457-4900
FAA	Federal Aviation Administration (U. S. Dept. of Transportation) 800 Independence Ave., SW; Washington, DC 20590
FCC	Federal Communications Commission 1919 M St., NW; Washington, D C 20554 202/632-7000
FCI	Fluid Controls Institute U.S. Highway One, Plaza 222; Tequesta, FL 33458; 305/746-6466
FGMA	Flat Glass Marketing Association 3310 Harrison; Topeka, KS 66611; 913/266-7013
FHA	Federal Housing Administration (U. S. Dept. of HUD) 451 - 7th St., SW; Washington, D C 20201
FM	Factory Mutual Engineering Corp. 1151 Boston-Providence Turnpike; Norwood, MA 02062 617/762-4300
FS	Federal Specification (General Services Admin.) Obtain from your Regional GSA Office, or purchase from GSA Specifications Unit (WFSIS); 7th and D Streets, SW; Washington, DC 20406; 202/472-2205 or 2140
FTI	Facing Tile Institute c/o Box 8880; Canton, OH 44711; 216/488-1211
GA	Gypsum Association 1603 Orrington Aven.; Evanston, IL 60201 312/491-1744
HPMA	Hardwood Plywood Manufacturers Association P. O. Box 2789, Reston, VA. 22090 703/435-2900
IEEE	Institute of Electrical and Electronic Engineers, Inc. 345 E. 47th St.; New York, NY 10017; 212/705-790
IESNA	Illuminating Engineering Society of North America

	345 E. 47th St.; New York, NY 10017 212/705-7926
ILI	Indiana Limestone Institute of America Stone City Bank Bldg.; Bedford, IN 47421; 812/275-4425
IRI	Industrial Risk Insurers 85 Woodland St.; Hartford, CT 06102; 203/525-2601
ISA	Instrument Society of America P. O. Box 12277; Research Triangle Park, NC 27709; 919/549-8411
LEED	Leadership in Energy and Environmental Design U. S. Green Building Council 1800 Massachusetts Avenue NW, Suite 300 Washington , DC 20036 (800) 795-1747
MCAA	Mechanical Contractors Association of America 5530 Wisconsin Aven.; Chevy Chase, MD 20815 202/654-7960
MIA	Marble Institute of America 33505 State St.; Farmington, MI 48024 313/476-5558
MIL	Military Standardization Documents (U.S. Dept. of Defense) Naval Publications and Forms Center 5801 Tabor Ave.; Philadelphia, PA 19120
ML/SFA	Metal Lath/Steel Framing Association 221 N. LaSalle St.; Chicago, IL 60601 312/346-1600
MSS	Manufacturers Standardization Society of the Valve and Fittings Industry 5203 Leesburg Pike; Falls Church, VA 22041; 703/998-7996
NAAMM	National Association of Architectural Metal Manufacturers 221 N. Lasalle St.; Chicago, IL 60601 312/346-1600
NAPF	National Association of Plastic Fabricators 1701 N. St., NW; Washington, DC 20036; 202/233-2504
NBGQA	National Building Granite Quarries Association c/o H. E. Fletcher Co.; West Chelmsford, MA 01863
NBS	National Bureau of Standards (U.S. Dept. of Commerce) Gaithersburg, MD 20234

	301/921-1000
NCMA	National Concrete Masonry Association P. O. Box 781; Herndon, VA 22070 703/435-4900
NEC	National Electrical Code (by NFPA)
NEII	National Elevator Industry, Inc. 600 Third Aven.; New York, NY 10016 212/986-1545
NECA	National Electrical Contractors Association 7315 Wisconsin Aven.; Bethesda, MD 20814 301/657-3110
NEII	National Elevator Industry, Inc. 600 Third Avenue; New York, NY 10016 212/986-1545
NEMA	National Electrical Manufacturers Association 2101 L St., NW; Washington, DC 20037 202/457-8400
NFPA	National Fire Protection Association Batterymarch Park; Quincy, MA 02269 617/328-9290
NFPA	National Forest Products Association 1619 Massachusetts Aven.; NW; Washington, DC 20036 202/797-5800
NHLA	National Hardwood Lumber Association P. O. box 34518; Memphis, TN 38104; 901/377-1818
NPA	National Particleboard Association 2306 Perkins Pl.; Silver Spring, MD 20910; 301/587-2204
NRCA	National Roofing Contractors Association 8600 Bryn Marr Aven.; Chicago, Il. 60631 312/693-0700
NSF	National Sanitation Foundation P. O. Box 1468; Ann Arbor, MI 48106 313/769-8010
NSSEA	National School Supply and Equipment Association 1500 Wilson Blvd.; Arlington, VA. 22209 703/524-8819
NTMA	National Terrazzo and Mosaic Association 3166 Des Plains Ave.; Des Plains, IL 60018

312/635-7744

NWMA	National Wood Manufacturers Association 205 West Touhy Avenue; Park Ridge, IL 60068; 312/823-6747
OSHA	Occupational Safety Health Administration (U.S.Dept. of Labor) Government Printing Office; Washington, DC 20402
PCI	Prestressed Concrete Institute 20 N. Wacker Dr., Chicago, IL 60606 312/346-4071
PDI	Plumbing and Drainage Istitute 5342 Blvd., Pl.; Indianapolis, IN 46208 317/251-5298
PEI	Porcelain Enamel Institute 1911 N. Fort Myer; Arlington, VA 22209 703/527-5257
PS	Product Standard of NBS (U.S. Dept. of Commerce) Government Printing Office; Washington, DC 20402
RFCI	Resilient Floor Covering Institute 1030 15th St.; NW; Washington, DC 20005 202/833-2635
RIS	Redwood Inspection Service (Grading Rules) 627 Montgomery; San Francisco, CA 94111
SAMA	Scientific Apparatus Makers Association 110I 16th St., NW; Washington, DC 20036 202/223-1360
SCAQMD	South Coast Air Quality Management District 21865 Copley Drive Diamond Bar, CA 91765 (909) 396-2000
SDI	Steel Deck Institute P. O. Box 3812; St. Louis, MO 63122 314/965-1741
SDI	Steel Door Institute 712 Lakewood Cnt. N.; Cleveland, OH 44107 216/226-7700
SHLMA	Southern Hardwood Lumber Manufacturers Association 805 Sterick Bld.; Memphis, TN. 38103 901/525-8221
SIGMA	Sealed Insulating Glass Manufacturers Association

	111 E. Wacker Dr.; Chicago, IL. 60601 312/644-6610
SJI	Steel Joist Institute 1703 Parham Rd.; Richmond, VA 23229 804/288-3071
SMACNA	Sheet Metal and Air Conditioning Contractor's National Association P. O. Box 70; Merrifield, VA 22116
SPIB	Southern Pine Inspection Bureau (Grading Rules) 4709 Scenic Hwy.; Pensacola, FL 32504; 904/434-2611
SSPC	Steel Structures Painting Council 4400 5th Avenue; Pittsburgh, PA 15213; 412/578-3327
TCA	Tile Council of America P. O. Box 326, Princeton, NJ 08540; 609/921-7050
TIMA	Thermal Insulation Manufacturers Association 7 Kirby Plaza; Mt. Kisco, NY 10549; 914/241-2284
TPI	Truss Plate Institute 100 W. Church St., Frederick, MD 21701; 301/694-6100
UL	Underwriters Laboratories 333 Pfingsten Rd.; Northbrook, IL 60062; 312/272-8800
WCLIB	West Coast Lumber Inspection Bureau (Grading Rules) P. O. Box 2315; Portland, OR 97223; 503/639-0651
WIC	Woodwork Institute of California 1833 Broadway; Fresno, CA 93773; 209/233-9035
WRI	Wire Reinforcement Institute 7900 Westpark drive; McLean, VA. 22102; 703/790-9790
WSFI	Wood and Synthetic Flooring Institute 2400 E. Devon; Des Plaines, IL 60018; 312/635-7700
WWPA	Western Wood Products Association (Grading Rules) 1500 Yeon Bldg.; Portland, OR 97204; 503/224-3930

WWPA Woven Wire Products Association
 108 W. Lake St.; Chicago, IL 60601;
 312/332-6502

END OF SECTION

RELATED DOCUMENTS:

The general provisions of the Contract, including General and Supplementary Conditions, and General Requirements, and Division 1 specifications that apply to the work specified in this Section.

PART 1 - GENERAL

RELATED DOCUMENTS:

Drawings and General Provisions of Contract, including General and Supplementary Conditions and Division-1 Specification Sections, apply to work of this section.

DESCRIPTION OF WORK:

Extent of demolition is shown on the plans. Refer to all Drawings and project phasing requirements..

Demolition requires the removal and subsequent off-site disposal of the following but is not limited to:

Removal of asphalt or concrete paving, with curb and guttering.

Removal of building structures and structural elements, complete with foundations – including concrete floors/walks and exterior canopies.

Removal of building exterior wall and roof components.

Removal of interior walls and components.

Removal of partitions and doors.

Removal of windows and window walls.

Removal of ceiling systems, floor finishes and wall finishes.

Removal of underground elements and components; piping and accessories.

Removal of plumbing, electrical and mechanical equipment.

Hazardous materials abatement.

Cutting concrete floors, masonry walls and ceilings for piping, ducts, and conduit is included with the work of the respective mechanical and electrical Divisions 15 and 16 Specification Sections.

Locating and identification of existing underground utilities.

SUBMITTALS:

Demolition Schedule: Submit schedule indicating proposed methods and sequence of operations for selective demolition work to Owner's Representative for review prior to commencement of work. Include coordination for shut-off, capping, and continuation of utility services as required, together with details for dust and noise control protection.

Incorporate all selective demolition and abatement operations and phases into the Project CPM Schedule.

Coordinate with Owner's continuing occupation of portions of existing building.

JOB CONDITIONS:

Occupancy: Owner will be continuously occupying the building immediately adjacent to areas of selective demolition. Conduct selective demolition work in a manner that will minimize need for disruption of Owner's normal operations. Provide minimum of 72 hours advance notice to Owner of demolition activities which will severely impact Owner's normal operations.

Condition of Structures: Owner assumes no responsibility for actual condition of items or structures to be demolished.

Protections: Provide temporary barricades and other forms of protection as required to protect personnel and general public from injury due to demolition work.

Provide interior and exterior shoring, bracing or support to prevent movement, settlement, or collapse of structure or element to be demolished, and adjacent facilities or work to remain.

Protect from damage existing finish work that is to remain in place and becomes exposed during demolition operations.

Protect floors with suitable coverings when necessary.

Construct temporary insulated solid dustproof partitions where required to separate areas where noisy or extensive dirt or dust operations are performed. Equip partitions with dustproof doors and security locks if required.

Provide temporary weather protection, including temporary weather walls, during interval between demolition and removal of existing construction on exterior surfaces, and installation of new construction to insure that no water leakage or damage occurs to structure or interior areas of existing buildings.

Remove protections at completion of work.

Damages: Promptly repair damages caused to adjacent facilities by demolition work at no cost to Owner.

Traffic: Conduct selective demolition operations and debris removal in a manner to ensure minimum interference with roads, streets, walks, and other adjacent occupied or used facilities.

Do not close, block or otherwise obstruct streets, walks or other occupied or used facilities without written permission from authorities having jurisdiction. Provide alternate routes around closed or obstructed traffic ways if required by governing regulations.

Explosives: Use of explosives will not be permitted.

Utility Services: Maintain existing utilities indicated to remain, keep in service, and protect against damage during demolition operations.

Environmental Controls: Use water sprinkling, temporary enclosures, and other suitable methods to limit dust and dirt rising and scattering in air to lowest practical level. Comply with governing regulations pertaining to environmental protection.

Do not use water when it may create hazardous or objectionable conditions such as ice, flooding, and pollution.

HAZARDOUS MATERIALS

Asbestos containing materials are identified in ~~existing windows, floors and pipes~~ at ~~the existing West Edgecombe Middle Eastern Elementary~~ School and are the responsibility of the contractor to remove and dispose of in a legal manner, using licensed abatement designers and licensed abatement subcontractors. GC is responsible for all required air monitoring and post-abatement testing, obtaining final clearances, as required by the Abatement Designer and applicable regulatory code requirements. Master project construction schedule ~~for the Beaufort PK-3 School for West Edgecombe Middle School~~ shall incorporate all abatement operations. Refer to and coordinate with the approved project construction schedule and the Supplementary General Conditions. Bidders shall reference the Owner's ACM / AHERA Reports, as part of the contract documents.

~~No asbestos containing materials are identified in the existing windows at GW Carver Elementary School. Bidders shall reference the Owner's ACM Reports, as part of the contract documents.~~

LEAD PAINT

If the building is constructed before 1978, all contractors are to assume that all painted surfaces inside the existing building may contain lead paint. The contractors are required to comply with OSHA Lead Construction Standard 29 CFR 1926.62.

All demolition debris can be disposed of at C&D landfill as long as the painted surfaces matrix has not been disturbed. For patching against the painted surfaces and painting, sanding, cutting etc. should be done by company who has received RRP certification for disturbing lead paint in a closed environment where children 6 years of age and under can enter the space during or after the work is completed. Information for RRP certification can be obtained from N. C. Health Hazard Control Unit, Raleigh, NC. Phone No. (919) 707-5950 / Don Chaney at (919) 707-5974.

Lead-Based Paint Renovation, Repair, and Painting: Firms and renovators who perform renovations in housing or child occupied facilities built before 1978 must be certified by the Health Hazards Control Unit (HHCU).

All work shall comply with requirements as published by the EPA Lead-Based Paint Renovation, Repair and Painting Rule in the Code of Federal Regulations.

Samples: For determining whether components are free of lead-based paint, certified renovators may collect paint chip samples and submit samples to a laboratory recognized by NLLAP for analysis. Required paint chip samples documentation shall be prepared and maintained by the certified renovator for three years.

At interior and exterior areas suspected to be or are tested positive for lead based paints, provide vertical containment consisting of a minimum of plastic sheeting or other impermeable material on a rigid frame, or an equivalent system of containing the work area. Vertical containment shall comply with requirements as published by the EPA Lead-Based Paint Renovation, Repair and Painting Rule in the Code of Federal Regulations.

HEPA vacuum cleaners must be designed so that all the air drawn into the machine is expelled through a HEPA filter with no air leaking past or around the filter.

Machines used to remove paint or other surface coatings through high speed operation such as sanding, grinding, power planing, abrasive blasting, or sandblasting, is prohibited on painted surfaces unless such machines have shrouds or containment systems and are equipped with a HEPA vacuum attachment to collect dust and debris at the point of generation. Machines must be operated so that no visible dust or release of air occurs outside the shroud or containment system.

PART 2 - PRODUCTS (Not Applicable)

PART 3 – EXECUTION

INSPECTION:

Prior to commencement of demolition work, inspect areas in which work will be performed. Photograph existing conditions to structure surfaces, equipment or to surrounding properties which could be misconstrued as damage resulting from selective demolition work; file with Owner's Representative prior to starting work.

LOCATING EXISTING UNDERGROUND UTILITIES:

Prior to commencement of groundbreaking work, contractor shall provide for and retain a private utilities locating firm. All underground utilities within the construction limits shall be located, marked and identified by the private utility location service, prior to any ground breaking. All information shall be documented in a contractor's As-Built drawings format.

PREPARATION:

Provide interior and exterior shoring, bracing, or support to prevent movement, settlement or collapse of structures to be demolished and adjacent facilities to remain.

Cease operations and notify the Owner's Representative immediately if safety of structure appears to be endangered. Take precautions to support structure until determination is made for continuing operations.

Cover and protect furniture, equipment and fixtures to remain from soiling or damage when demolition work is performed in rooms or areas from which such items have not been removed.

Erect and maintain dust-proof partitions and closures as required to prevent spread of dust or fumes to occupied portions of the building.

Where selective demolition occurs immediately adjacent to occupied portions of the building, construct temporary dust-proof partitions of minimum 4" studs, 5/8" drywall (joints taped and mudded) on occupied side, 1/2" fire-retardant plywood on demolition side, and fill partition cavity with sound-deadening insulation.

Provide weatherproof closures for exterior openings resulting from demolition work.

Where ongoing new construction occurs immediately adjacent to occupied portions of the buildings, construct temporary weather-proof partitions of minimum 4" studs, 5/8" drywall (joints taped and mudded) on occupied side, 1/2" fire-retardant plywood, and 1/2" Densglas exterior grade gypsum sheathing with sealed joints, on the construction side, and fill partition cavity with sound-deadening insulation.

Locate, identify, stub off and disconnect utility services that are not indicated to remain.

DEMOLITION:

Perform demolition work in a systematic manner. Use such methods as required to complete work indicated on Drawings in accordance with demolition schedule and governing regulations.

Demolish concrete and masonry in small sections. Cut concrete and masonry at junctures with construction to remain using power-driven masonry saw or hand tools; do not use power-driven impact tools.

Locate demolition equipment throughout structure and promptly remove debris to avoid imposing excessive loads on supporting walls, floors or framing.

Provide services for effective air and water pollution controls as required by local authorities having jurisdiction.

If unanticipated mechanical, electrical or structural elements which conflict with intended function or design are encountered, investigate and measure both nature and extent of the conflict. Submit report to Owner's Representative in written, accurate detail. Pending receipt of directive from Owner's Representative re-arrange selective demolition schedule as necessary to continue overall job progress without delay.

DISPOSAL OF DEMOLISHED MATERIALS:

The Owner reserves salvage rights to equipment and material, items to be determined at pre-construction conference. At request of the Owner, Contractor shall coordinate the scheduled removal of designated material to be salvaged and place said material outside of building, on site, for removal by Owner.

Remove all debris, rubbish and other materials resulting from demolition operations and not salvaged by the Owner from building site. Transport and legally dispose of materials off-site.

Hazardous materials disposal during demolition operations, shall comply with all applicable regulations, laws, and ordinances, concerning removal, handling and protection against exposure or environmental pollution.

Burning of removed materials is not permitted on project sites.

CLEAN-UP AND REPAIR:

Upon completion of demolition work, remove tools, equipment and demolished materials from site. Remove protections and leave interior areas broom clean.

Repair demolition performed in excess of that required. Return structures and surfaces to remain to condition existing prior commencement of demolition work. Repair adjacent construction or surfaces soiled or damaged by demolition work to like new condition.

END OF SECTION

RELATED DOCUMENTS:

The general provisions of the Contract, including General and Supplementary Conditions, and General Requirements, and Division 1 specifications that apply to the work specified in this Section.

PART 1: GENERAL

DESCRIPTION OF WORK:

Extend of site clearing is shown on drawings.

Site clearing work includes, but is not limited to:

- Removal of trees and other vegetation.
- Topsoil stripping and stockpiling.
- Clearing and grubbing.

JOB CONDITIONS:

Traffic: Conduct site clearing operations to ensure minimum interference with roads, streets, walks, and other adjacent occupied or used facilities. Do not close or obstruct streets, walks or other occupied or used facilities without permission from authorities having jurisdiction.

Protection of Existing Improvements: Provide protection necessary to prevent damage to existing improvements indicated to remain in place.

Protect improvements on adjoining properties and on Owner's property.

Restore damaged improvements to their original condition, as acceptable to parties having jurisdiction.

PART 2: PRODUCTS

Not applicable to work of this section.

PART 3: EXECUTION

SITE CLEARING:

General: Remove trees, shrubs, grass and other vegetation, improvements, or obstructions interfering with installation of new construction. Remove such items elsewhere on site or premises as specifically indicated. Removal includes digging out stumps and roots, and backfill with suitable compacted fill material.

Topsoil: Topsoil is defined as friable clay loam surface soil found in a depth of not less than 4". Satisfactory topsoil is reasonably free of subsoil, clay lumps, stones, and other objects over 2" in diameter, and without weeds, roots, and other objectionable material.

Strip topsoil to whatever depths encountered in a manner to prevent intermingling with underlying subsoil or other objectionable material.

Remove heavy growths of grass from areas before stripping.

Stockpile a quantity of topsoil to allow a full 3" topsoil layer to be redistributed throughout all finish grade areas.

Stockpile topsoil in storage piles in areas shown, or where directed. Construct storage piles to freely drain surface water. Cover storage piles if required to prevent wind-blown dust. Provide erosion control measures around perimeters of storage piles.

Dispose of unsuitable or excess topsoil same as waste material, herein specified.

Clearing and Grubbing: Clear site of trees, shrubs and other vegetation, except for those indicated to be left standing.

Removal of Improvements: Remove existing above-grade and below-grade improvements necessary to permit construction, and other work as indicated.

DISPOSAL OF WASTE MATERIALS:

Burning on Owner's Property: Burning is allowed on the Owner's property, with proper permits.

Removal from Owner's Property: Remove waste materials and unsuitable and excess topsoil from Owner's property and dispose of off-site in legal manner.

END OF SECTION

RELATED DOCUMENTS:

The general provisions of the Contract, including General and Supplementary Conditions, and General Requirements, and Division 1 specifications that apply to the work specified in this Section.

PART 1: GENERAL

DESCRIPTION OF WORK:

Extent of earthwork is indicated on drawings.

Earthwork includes all excavation (removal of material) necessary to reach subgrade elevations indicated. This includes subsequent disposal of material. Preparation of subgrade for building pads, parking areas, access roads and storm drainage installation are included as part of this work.

Refer to Geotechnical Report recommendations for fill. On site excavated soils may be used in non-structural areas. Off-site select material must be used for fill and trench backfill at structural areas (buildings, drives, and walkways). Off-site select material used for this purpose is to be included in bid and is not to be charged against the off-site fill allowance under Section 01056.

QUALITY ASSURANCE

TESTING AND INSPECTION SERVICE:

All sub-grade and stone base shall be proof-rolled in accordance with NCDOT Standards and as directed by Engineer. Project Engineer shall be present at proof rolling.

CODES AND STANDARDS:

All work conducted as part of this are to be in compliance with NCDOT specifications for Roadway Construction.

SUBMITTALS:

Test Reports-Excavating: Submit following reports directly to Engineer from the testing services, with copy to Contractor:

Field density test reports on all trench backfill located beneath existing or proposed roadways.

JOB CONDITIONS:

Existing Utilities: Locate existing underground utilities in areas of work. If utilities are to remain in place, provide adequate means of support and protection during earthwork operations.

Should uncharted, or incorrectly charted, piping or other utilities be encountered during excavation, consult utility owner and Project Engineer immediately for directions. Cooperate with Owner and utility companies in keeping respective services and facilities in operation. Repair damaged utilities to satisfaction of utility owner.

Do not interrupt existing utilities serving facilities occupied and used by Owner or others, during occupied hours, except when permitted in writing by Engineer and then only after acceptable temporary utility services have been provided.

Provide minimum of 48-hour notice to Engineer, Owner, and Local Government and receive written notice to proceed before interrupting any utility.

Demolish and completely remove from site existing underground utilities indicated to be removed. Coordinate with utility companies for shut-off of services if lines are active.

Protection of Persons and Property: Barricade open excavations occurring as part of this work and post with warning lights.

Operate warning lights as recommended by authorities having jurisdiction.

Protect structures, utilities, sidewalks, pavements, and other facilities from damage caused by settlement, lateral movement, undermining, washout and other hazards created by earthwork operations.

PART 2: PRODUCTS

SOIL MATERIALS

DEFINITIONS:

Satisfactory soil materials are defined as those complying with ASTM D 2487 soil classification groups GW, GP, GM, SM, SW and SP.

Drainage Fill: Washed, evenly graded mixture of crushed No. 57 - Stone.

Off-Site Select Backfill: Approved borrow material of coarse sands, fine sands or sandy clay mixture. Required for fill and trench backfill at structural areas (buildings, drives, and walkways).

Backfill Materials: Satisfactory (tested and approved by soils engineer) Class I through Class VII soil materials free of clay, rock or gravel larger than 2" in any dimension, debris, waste, frozen material, vegetable and other deleterious matter.

Excavation: Removal of material encountered to subgrade elevations and the reuse or disposal of materials removed. Refer to the following section for additional definitions and classified excavations.

Unauthorized Excavation: Removing materials beyond indicated invert/subgrade elevations or dimensions without direction by the design authority, or Owner. Unauthorized excavations, as well as associated remedial work directed by design authority or Owner, shall be at contractor's expense. Backfill and compact unauthorized excavations as specified for authorized excavations of same classification, unless otherwise directed by design authority.

Subgrade: The uppermost surface of an excavation (after stripping is fully complete) or the top surface of a new fill or backfill immediately below base course, drainage course, walks, drainage fill, slab base materials, or topsoil materials.

Borrow: Suitable (tested and approved by soils engineer) soil materials obtained from off-site when sufficient approved soil material is not available from on-site excavations.

Surface Course: The top layer of the pavement structure placed on aggregate base course, asphalt base course, or subgrade, as required.

Aggregate Base Course: Aggregate material layer placed between the subgrade elevation and asphalt paving course, meeting the requirements of Section 910-1, Paragraph (a) of "Standard Specifications for Roads and Structures" by NCDOT.

Bedding Course: Layer placed over excavated subgrade in trench bottoms before laying pipe.

Structures: Buildings, footings, foundations, retaining walls, slabs-on-grade, curbs, tanks, mechanical and electrical appurtenances, or other man-made stationary features constructed above or below ground surface.

Utilities include on-site underground pipes, conduits, ducts, and cables, as well as underground services within building lines.

UNIT PRICES

Rock Measurement: Volume of rock actually removed, measured in original position (as observed and recorded by the Geotechnical Engineer), but not exceeding the following:

1. 24 inches outside of concrete forms other than at footings.
2. 12 inches outside of concrete forms at footings.
3. 6 inches outside of minimum required dimensions of concrete cast against grade.
4. 6 inches beneath bottom of concrete slabs-on-grade.
5. 6 inches beneath bottom of footings.
6. 6 inches beneath invert elevation of pipe and/or related structures in trenches, and the greater of 24 inches wider than outside pipe diameter, or 42 inches wide (regardless of trench box sizes). 24 inches wider than related structures in trenches.

Unsuitable Soil Measurement: Volume of unsuitable soil actually removed below subgrade elevations (as recommended and classified by Owner's Geotechnical Testing Firm) measured in-place, but not exceeding the following:

1. 24 inches outside of concrete forms other than at footings.
2. 12 inches outside of concrete forms at footings.
3. 6 inches outside of minimum required dimensions of concrete cast against grade.
4. 12 inches beneath invert elevation of pipe and/or related structures in trenches, and the greater of 24 inches wider than outside pipe diameter, or 42 inches wide (regardless of trench box sizes). 24 inches wider than related structures in trenches.
5. Minimum dimensions as recommended by Owner's Geotechnical Testing Firm in any other areas.

Unit prices for unsuitable soil and rock removal shall include all work and materials as defined in Division 1 Sections, including any required replacement with suitable fill soils or other materials, as required.

Structural Geo-Grids: Integrally Formed Biaxial Geogrid for base reinforcement and subgrade improvement formed with polypropylene polymer in roll form providing positive mechanical interlock. Provide Tensar BX1100 Geogrid.

PART 3: EXECUTION

EXCAVATION CLASSIFICATIONS:

Excavation Classifications: All excavation is classified as General Excavation except for Mass Rock, Trench Rock and Unsuitable Soil Materials as defined in this section.

General Excavation: Excavation, removal and/or disposal of pavements and other obstructions visible on surface, underground structures, utilities, and other items indicated to be demolished and/or removed; together with soil, boulders, and other materials encountered that are not classified as Mass Rock, Trench Rock, Unsuitable Soil, or unauthorized excavation.

- a. Intermittent drilling, ripping or blasting to increase production and not necessary to permit excavation of materials encountered will be considered general excavation.

- b. Soil (irregardless of nature) or other debris encountered above plan subgrade elevations shall be considered general excavation unless determined by the Owner's Geotechnical Testing Firm to meet the definition of Mass Rock.

Unsuitable Soil Excavation: Removal and disposal of soil materials or other debris encountered at or below plan subgrade elevations, which are deemed unsuitable to remain in place by the owner's Geotechnical Testing Firm or design authority.

- a. Soil and/or other debris encountered above plan subgrade shall be considered general excavation.
- b. Soil material which, in the opinion of the Owner's Geotechnical Testing Firm, can be repaired by scarifying, drying or moistening, and recompacting, or material which is made unsuitable by delay of work, lack of protection, inclement weather, or other actions of the Contractor or their Sub-Contractors shall not be considered as unsuitable soil and shall be repaired or replaced by the contractor at no additional cost to the Owner.
- c. Any material moved or removed without the prior classification, measurement and approval by the Owner's Geotechnical Testing Firm or design authority will be considered as general excavation.

Mass Rock Excavation: Removal of a rock formation within an open excavation that (1) is a boulder larger than 1.5 cubic yards in one piece, or (2) cannot be excavated without systematic drilling and blasting. In the event Mass Rock (as defined above) is encountered, the Contractor shall demonstrate (at no additional cost to the owner) to the Owner's Geotechnical Testing Firm that the rock cannot be ripped with equipment equivalent to the following size and performance ratings, without systematic drilling and blasting.

- a. Mass Rock Excavation Equipment: Late-model, track-type tractor rated at not less than 270 hp flywheel power with a draw bar pull of 65,000 lbs at 1 mph in the lowest available gear, and the highest normal operating rpm pulling a sharp, single-toothed shank ripper. The equipment operator should be adequately qualified and experienced with ripping rock with this type equipment.

Trench Rock Excavation: Removal of a rock formation within a trench excavation that (1) is a boulder larger than 1.0 cubic yards in one piece, or (2) cannot be excavated by rock excavating equipment equivalent to the following in size and performance ratings, without systematic drilling and blasting.

- a. Trench Rock Excavation Equipment: Late-model, track mounted hydraulic excavator equipped with a 42-inch wide (or smaller), short tip-radius bucket with rock teeth; rated at not less than 120-hp flywheel power with a pull of not less than 36,500-lb at a rate of 10 cubic yards per hour. The equipment operator should be adequately qualified and experienced with excavating rock with this type equipment.

Classified Excavation Requirements:

- a. Excavations more than 10 feet in width and pits more than 30 feet in either length or width are defined as open excavations.
- b. Contractor shall expose and clean the surface and any exposed areas of the rock material for classification and measurement (in-place) by the Owner's Geotechnical Testing Firm.
- c. Do not excavate rock or unsuitable soil until it has been classified and measured by the Owner's Geotechnical Testing Firm. Any material moved or removed without the prior classification and measurement by the Owner's Geotechnical Testing Firm will be considered as unclassified excavation.
- d. The Owner or the Owner's Geotechnical Testing Firm shall be the final judge on what is classified as Mass Rock, Trench Rock, or Unsuitable Soils.
- e. The contractor may be required to provide equipment specification data verifying that the above minimum-rated equipment will be used for demonstration purposes. The equipment shall be in good repair and proper working condition. The contractor may be required to provide verification of the equipment operator's qualifications and experience operating the noted equipment for rock removal purposes.

- f. Rippable rock, weathered rock, partially weathered rock, soft rock, or hard overburden soil, which is not classified as Mass Rock or Trench Rock according to the above definitions, shall be considered unclassified excavation.

EXCAVATION AND BACKFILL:

Roadway Excavation: Excavation for the roadways, drives, and parking areas shall conform to the lines, grades, cross sections, and dimensions indicated on the drawings and shall include the excavation of all unsuitable materials from the subgrade. Subgrade shall conform to proposed line, grade and cross-section. This operation shall include any reshaping and wetting or drying required to obtain proper compaction. All soft or otherwise unsuitable material shall be removed and replaced with approved off-site select material.

Proof Rolling and Undercut Excavation: When excavation has reached required subgrade elevations, provide a proof rolling of the prepared pavement subgrade with a loaded tandem axle dump truck (+25 tons) in the presence of the Owner's Geotechnical Testing Firm. The proof rolling shall be covered by the wheels of the proof rolling vehicle operating at a speed between 2 and 3 miles per hour.

Any areas that rut or pump excessively shall be allowed to dry or shall be undercut and backfilled with select material as directed by the Owner's Geotechnical Testing Firm.

After undercut and backfill operations are complete, a final proof rolling of the undercut areas will be performed in the presence of the Owner's Geotechnical Testing Firm.

Additional Excavation: When excavation has reached required invert/subgrade elevations, notify the Owner's Geotechnical Testing Firm, who will make an inspection of conditions.

Stability of Excavations: Slope sides of excavations to comply with local codes and ordinances having jurisdiction. Shore and brace where sloping is not possible because of space restrictions or stability of material excavated. Maintain sides and slopes of excavations in safe condition until completion of backfilling.

Shoring and Bracing: Provide materials for shoring and bracing, such as sheet piling, uprights, stringers and cross-braces, in good serviceable condition. Establish requirements for trench shoring and bracing to comply with local codes and authorities having jurisdiction.

Maintain shoring and bracing in excavations regardless of time period excavations will be open. Carry down shoring and bracing as excavation progresses.

Dewatering: Prevent surface water and subsurface or ground water from flowing into excavations and from flooding project site and surrounding area.

Do not allow water to accumulate in excavations. Remove water to prevent softening of excavation bottoms. Provide and maintain pumps, well points, sumps, suction and discharge lines, and other dewatering system components necessary to convey water away from excavations.

Establish and maintain temporary drainage ditches and other diversions outside excavation limits to convey rain water and water removed from excavations to collecting or run-off areas. Do not use trench excavations as temporary drainage ditches.

Material Storage: Stockpile satisfactory excavated materials where directed, until required for backfill or fill. Place, grade and shape stockpiles for proper drainage.

Excavation for Pavement: Cut surface directly beneath proposed pavement to comply with cross-sections, elevations and grades as shown.

CONTRACTOR IS TO CONTACT NC ONE CALL 48 HOURS PRIOR TO ANY EXCAVATION. CONTRACTOR SHOULD UNDERSTAND THAT ONCE EXISTING UTILITIES ARE LOCATED THAT SAID LOCATION IS VALID ONLY FOR TEN DAYS.

Should it be necessary to cut pavement or otherwise work within a public street, the North Carolina Department of Transportation is to be contacted prior to work, and applicable permits obtained.

TRENCH BACKFILL:

Excavation, bedding, haunching & backfilling shall conform to Section 02210 TRENCHING AND BACKFILLING FOR UTILITIES, and Drawings.

Refer to Geotechnical Report recommendations for trench backfill. On site excavated soils may be used in non-structural areas. Off site select material must be used for backfill at structural areas (buildings, drives, and walkways). Off site select material used for this purpose is to be included in bid and is not to be charged against the off site fill allowance under Section 01056.

Width of trenches at any point below top of pipe shall not be greater than outside diameter of pipe plus 16" for pipes measuring up to 30", and 24" for pipe measuring greater than 30", to permit satisfactory jointing and thorough tamping of bedding material under and around pipe. Care shall be taken not to over-excavate.

Bedding surface for piping shall provide a firm foundation of uniform density throughout entire length of pipe. Carefully bed pipe in a sand or stone material foundation as specified, that has been accurately shaped and rounded to conform to lowest 1/4 of outside portion of circular pipe, or lower curved portion of pipe arch for entire length of pipe or arch. When necessary, tamp bedding firmly. Bell holes and depressions for joints shall be only of such length, depth, and width as required for properly making particular type joint.

Bed pipe located under pavement or building footprints in a sand or stone material foundation as specified and as indicated on Drawings.

Existing utility lines shall be protected from damage during excavation and backfilling, and, if damaged, shall be repaired by the Contractor at his expense. In the event that the Contractor damages any existing utility lines, he shall report thereof immediately. If it is determined that repairs shall be made by the Contractor, such repairs shall be ordered under terms of other sections of these specifications.

After bedding has been prepared and pipe installed, selected material from excavation or borrow, at a moisture content that will facilitate compaction, shall be placed along both sides of pipe in layers not exceeding 6" in compacted depth. Bring backfill up evenly on both sides of pipe for its full length. Care shall be taken to ensure thorough compaction of fill under haunches of pipe. Thoroughly compact each layer to an elevation of at least 12" above top of pipe. Backfill and compact remainder of trench by spreading and rolling, or compact by mechanical rammers or tampers in layers not exceeding 8".

After bedding has been prepared and pipe installed for locations under pavement and building footprints, backfill and compact remainder of trench with selected Type II, III or IV material from excavation or borrow.

In compacting or rolling or operating heavy equipment parallel with pipe, displacement of or injury to pipe shall be avoided. Any pipe damaged thereby shall be repaired or replaced, at option of Engineer, and at expense of the Contractor.

When fill or backfill is required to be compacted to any specified density factor, tests shall be executed by an approved laboratory to ascertain compliance with requirements, at the expense of the Owner through the established Testing Allowance. One test shall be made for each 50 linear feet of open trench. Cost of laboratory services shall be borne by the Contractor as a part of costs for this section of work for any repeat tests for any specific area which fails to meet requirements.

Cold Weather Protection: Protect excavation bottoms against freezing when atmospheric temperature is less than 35 degrees F (1 degree C).

GENERAL BACKFILL:

Place acceptable soil fill material in layers to required subgrade elevations, for each area classification listed below.

In excavations, use satisfactory excavated or borrow material.

Under grassed areas, use satisfactory excavated or borrow material.

Under structural areas (buildings, walks and drive pavements), use approved off-site select borrow material.

Backfill excavations as promptly as work permits, but not until completion of the following: Inspection, testing, approval, and recording locations of underground utilities.

Ground Surface Preparation: Remove vegetation, debris, unsatisfactory soil materials, obstructions, and deleterious materials from ground surface prior to placement of fills. Plow, strip, or break-up sloped surfaces steeper than 1 vertical to 4 horizontals so that fill material will bond with existing surface.

When existing ground surface has a density less than that specified under "Compaction" for particular area classification, break up ground surface, pulverize, moisture-condition to optimum moisture content, and compact to required depth and percentage of maximum density.

Placement and Compaction: Place backfill and fill materials in layers not more than 8" in loose depth for material compacted by heavy compaction equipment, and not more than 4" in loose depth for material compacted by hand-operated tampers.

Before compaction, moisten or aerate each layer as necessary to provide optimum moisture content.

Compact each layer to required percentage of maximum dry density or relative dry density for each area classification. Do not place backfill or fill material on surfaces that are muddy, frozen, or contain frost or ice.

Place backfill and fill materials evenly adjacent to structures, piping or conduit to required elevations. Take care to prevent wedging action of backfill against structures or displacement of piping or conduit by carrying material uniformly around structure, piping or conduit to approximately same elevation in each lift.

COMPACTION:

General: Control soil compaction during construction providing minimum percentage of density specified for each area classification indicated below.

Percentage of Maximum Density Requirements: Compact soil to not less than the following percentages of maximum density for soils which exhibit a well-defined moisture density relationship (cohesive soils) determined in accordance with ASTM D 698;

Structures, Building Slabs and Steps: Compact each layer of backfill or fill material at 95 % maximum density for cohesive material or 98 % for cohesionless material to within 2' of surface. From 2' deep to finish grade, compact 98% maximum density for cohesive material or 100% relative density for cohesionless materia.

Pavements: Compact each layer of backfill or fill material at 95% maximum dry density to within 6" of surface. From 6" deep to finish grade, compact to 100% maximum density in accordance with AASHTO-T99.

Lawn or Unpaved Areas: Compact top 6" of subgrade and each layer of backfill or fill material at 85% maximum density for cohesive soils and 90% relative density for cohesionless soils.

Walkways: Compact top 6" of subgrade and each layer of backfill or fill material at 90% maximum density for cohesive material or 95% relative density for cohesionless material.

Moisture Control: Where subgrade or layer of soil material must be moisture conditioned before compaction, uniformly apply water to surface of subgrade, or layer of soil material, to prevent free water appearing on surface during or subsequent to compaction operations.

Remove and replace, or scarify and air dry, soil material that is too wet to permit compaction to specified density.

Soil material that has been removed because it is too wet to permit compaction may be stockpiled or spread and allowed to dry. Assist drying by discing, harrowing or pulverizing until moisture content is reduced to a satisfactory value.

GRADING:

General: Uniformly grade areas within limits of grading under this section, including adjacent transition areas. Smooth finished surface within specified tolerances, compact with uniform levels or slopes between points where elevations are indicated, or between such points and existing grades.

Grade areas as shown on the Drawings to prevent ponding. Finish surface free from irregular surface changes, and as follows:

Lawn or Unpaved Areas: Finish areas to receive a minimum of 3" layer topsoil to within not more than 0.10' above or below required sub-grade elevations.

Walks: Shape surface of areas under walks to line, grade and cross-section, with finish surface not more than 0.05' above or below required subgrade elevation.

Pavements: Shape surface of areas under pavement to line, grade and cross-section, with finish surface not more than 1/2" above or below required subgrade elevation.

Patches in driveways and roadways shall be graded to depth required to match existing pavement or to provide minimum pavement specified.

Compaction: After grading, compact subgrade surfaces to the depth and indicated percentage of maximum or relative density for each area classification.

PAVEMENT SUBBASE COURSE:

General: Subbase course consists of placing subbase material, in layers of specified thickness, over subgrade surface to support a pavement base course.

Grade Control: During construction, maintain lines and grades including crown and cross-slope of subbase course.

Shoulders: Place shoulders along edges of subbase course to prevent lateral movement. Construct shoulders of acceptable soil materials, placed in such quantity to compact to thickness of each subbase course layer. Compact and roll at least a 12" width of shoulder simultaneously with compacting and rolling of each layer of subbase course.

Placing: Place subbase course material on prepared subgrade in layers of uniform thickness, conforming to indicated cross-section and thickness. Maintain optimum moisture content for compacting subbase material during placement operations.

When a compacted subbase course is shown to be 6" thick or less, place material in a single layer. When shown to be more than 6" thick, place material in equal layers, except no single layer more than 6" or less than 3" in thickness when compacted.

FIELD QUALITY CONTROL:

Quality Control Testing During Construction: Allow testing service to inspect and approve subgrades and fill layers before further construction work is performed.

If in opinion of Engineer, based on testing service reports and inspection, subgrade or fills which have been placed are below specified density, provide additional compaction and testing at no additional expense.

MAINTENANCE:

Protection of Graded Areas: Protect newly graded areas from traffic and erosion. Keep free of trash and debris.

Repair and re-establish grades in settled, eroded, and rutted areas to specified tolerances.

Reconditioning Compacted Areas: Where completed compacted areas are disturbed by subsequent construction operations or adverse weather, scarify surface, re-shape, and compact to required density prior to further construction.

Settling: Where settling is measurable or observable at excavated areas during general project warranty period, remove surface (pavement, lawn or other finish), add backfill material, compact, and replace surface treatment. Restore appearance, quality, and condition of surface or finish to match adjacent work, and eliminate evidence of restoration to greatest extent possible.

DISPOSAL OF EXCESS AND WASTE MATERIALS:

Removal from Owner's Property: Remove waste materials, including unacceptable excavated material, trash and debris, and dispose of off Owner's property.

Comply with and coordinate with the project Construction Waste Management Plan (CWMP).

END OF SECTION

RELATED DOCUMENTS:

The general provisions of the Contract, including General and Supplementary Conditions, and General Requirements, and Division 1 specifications that apply to the work specified in this Section.

PART 1 - GENERAL

- 1.1 DESCRIPTION: Perform site preparations, excavation, and backfilling of all materials encountered and to the depths required to complete the work as shown on the Drawings.
- 1.2 EXISTING CONDITIONS: Every reasonable effort has been made to provide accurate information on existing site conditions. The Contractor should become familiar with the site and satisfy himself as to the scope of work involved and the materials to be encountered. Any significant change in conditions should be immediately brought to the attention of the Owner's representative.
- 1.3 Refer to Geotechnical Report recommendations for trench backfill. On site excavated soils may be used in non-structural areas. Off site select material must be used for backfill at structural areas (buildings, drives, and walkways). Off site select material used for this purpose is to be included in bid and is not to be charged against the off site fill allowance under Section 01056.

PART 2 - MATERIALS

2.1 SOILS

- 2.1.1 General: Use soils free of organic matter, refuse, rocks and lumps greater than 4 inches in diameter and other deleterious matter.
- 2.1.2 Classification: For the purpose of this specification, soils to be used as fill material are grouped into seven classes according to soil properties and characteristics.

Class I	Clean gravel complying with ASTM C33, coarse aggregate No. 57.
Class II	Clean sand complying with ASTM C33, fine aggregate.
Class III	Clean gravels and sands complying with ASTM D2487, Types GW, GP, SW, and SP.
Class IV	Soil mixtures complying with ASTM D2487, Types GM, GC, SM, & SC.
Class V	Soil mixtures complying with ASTM D2487, Types ML and CL.
Class VI	Soil mixtures complying with ASTM D2487, Types MH and CL.
Class VII	Organic soil mixtures complying with ASTM D2487, Types OL, OH & PT.

PART 3 – EXECUTION

3.1 GENERAL

- 3.1.1 Familiarization: Prior to commencement of the earthwork, become thoroughly familiar with the site, the site conditions, and all portions of the work specified in this Section.
- 3.1.2 Approvals: Backfilling and grading operations shall not commence until all required inspections, tests and approvals have been completed. Work covered prior to inspection shall be uncovered for inspection purposes and backfilled at no additional cost to the Owner.

SURFACE PREPARATION

- 3.1.1 Clearing: Areas designated for clearing and required for construction operations shall be cleared of trees, brush, structures and other materials. Trees that are to remain shall be protected during clearing operations and subsequent work.
- 3.1.2 Grubbing: Roots, stumps and other materials shall be grubbed from the cleared areas to a depth of at least 18 inches. Tree stumps shall be grubbed in their entirety, including taproots where applicable.
- 3.1.3 Topsoil: Strip existing topsoil to a depth of 4 inches from areas to be excavated or graded. Stockpile the topsoil in a suitable area for use during final grading operations. Protect the topsoil from erosion.
- 3.1.4 Unsuitable Material: Remove sod, muck or other unsuitable material to firm subsoil in areas designated for filling or grading operations.
- 3.1.5 Disposal: Trees, stumps, roots, rubbish, unsuitable soil or other material resulting from surface preparation shall be removed from the site by the Contractor and disposed of.

3.2 EXCESS WATER CONTROL:

- 3.2.1 General: Grade and maintain all areas of the site to preclude surface runoff into excavations and prevent ponding of water.
- 3.2.2 Dewatering: Excavations shall be kept free of surface water and/or groundwater. Provide and maintain at all times the necessary means and devices to prevent water from entering the excavations and for removing all water entering the excavations.

3.3 TRENCHING, BACKFILLING AND COMPACTION FOR UTILITY SYSTEMS

- 3.3.1 General: Refer to specific utility sections in these Specifications for installation requirements. Trench, backfill, and compact as specified except as modified herein.
- 3.3.2 Trenching: Trench widths at and below the top of the pipe shall be the minimum necessary for proper installation. Trench banks above the top of the pipe shall be as vertical as practicable. Over-depth excavation shall be backfilled with suitable bedding material and compacted. The Contractor shall provide, at his expense and as directed by the Owner's testing firm representative, special bedding material or concrete encasement as may be necessary due to over excavation.
- 3.3.3 Depth: Trench to the lines and grades shown on the drawings. Where elevations are not shown, trench to depth sufficient to provide at least 36 inches of cover above the top of pipe, unless otherwise specified. Grade trenches to provide a constant slope free of sags and high spots.
- 3.3.4 Trench Bracing: Properly brace, sheet and support trench walls in strict conformance with all pertinent laws and regulations. Provide adequate bracing and shoring to protect adjacent improvements.
- 3.3.5 Bedding, Haunching, and Initial Backfill:

Storm sewer and sanitary sewer pipe beddings require minimum 6" No. 57 continuous Class I stone bedding material, coordinate thicknesses required with Drawing requirements. Tamp subgrade to provide firm, even bedding. Excavate bedding material to match the shape of the bottom of the pipe and bell, as detailed on the Drawings. Place Class I haunching material so as to provide full bearing around the bottom of the pipe.

Initial backfill shall be Class II, III, or IV placed in 12 inch maximum lifts to a level 12 inches above the top of pipe and compacted to a minimum 95 percent Standard Proctor by the AASHTO - T99 method. Coordinate with Drawings details.

3.3.6 Backfill: Backfill the remainder of the trench in accordance with the paragraphs below:

3.3.6.1 **Pavement Areas**: Compact the subgrade and fill material beneath paved areas and shoulders to a minimum 95 percent Standard Proctor by the AASHTO-T99 method. Compact top 6" of subgrade to 100 percent Standard Proctor by the AASHTO-T99 method.

3.3.6.2 **Landscaped Areas**: Compact the subgrade and fill to a minimum 90 percent standard proctor by the AASHTO-T99 method.

END OF SECTION

RELATED DOCUMENTS:

Drawings and general provisions of Contract, including General and Supplementary Conditions and Division-1 Specification sections, apply to work of this section.

PART 1: GENERAL

DESCRIPTION OF WORK:

Provide soil treatment for termite control, as herein specified.

QUALITY ASSURANCE:

In addition to requirements of these specifications, comply with manufacturer's instructions and recommendations for work, including preparation of substrate and application.

Engage a professional pest control operator, licensed in accordance with regulations of governing authorities for application of soil treatment solution.

JOB CONDITIONS:

Restrictions: Do not apply soil treatment solution until excavating, filling and grading operations are completed, except as otherwise required in construction operations.

To insure penetration, do not apply soil treatment to frozen or excessively wet soils or during inclement weather. Comply with handling and application instructions of the soil toxicant manufacturer.

SUBMITTALS:

Product Data: Submit manufacturer's technical data and application instructions.

SPECIFIC PRODUCT WARRANTY:

Furnish written warranty certifying that applied soil poisoning treatment will prevent infestation of subterranean termites and, that if subterranean termite activity is discovered during warranty period, Contractor will re-treat soil and repair or replace damage caused by termite infestation.

Provide warranty for a period of 5 years from date of treatment, signed by Applicator and Contractor.

PART 2: PRODUCTS

SOIL TREATMENT SOLUTION:

The pest control operator will submit the Safety Data Sheet and label of the termiticide he will use on the project. The termiticide must be currently approved as a termiticide by the N. C. Structural Pest Control Committee.

PART 3: EXECUTION

APPLICATION:

Surface Preparation: Remove foreign matter which could decrease effectiveness of treatment on areas to be treated. Loosen, rake, and level soil to be treated, except previously compacted areas under slabs and foundations. Toxicants may be applied before placement of compacted fill under slabs, if recommended by toxicant manufacturer.

All treatments (excluding the rate of application and treating techniques) must be performed as outlined on the termiticide's label.

All treatments in regards to rate of application and treatment technique will be performed as outlined in the N. C. Structural Pest Control Committee's Rules and Regulations as currently applies to treatment of commercial buildings under construction.

All treatments performed pursuant to Rule. -506 shall be performed at the label recommended rate and concentration only.

Minimum Treatment Requirements:

1. Establish a vertical barrier in the soil along inside of the main foundation wall; the entire perimeter of all multiple masonry chimney bases, pillars, pilasters, and piers; and both sides of partition or inner walls with a termiticide from the top of the grade to the top of the footing.
2. After a building or structure has been completed and the excavation filled and leveled, so that the final grade has been reached along the outside of the main foundation wall, establish a vertical barrier in the soil adjacent to the outside of the main foundation wall with a termiticide from the top of the grade to the top of the footing, according to the label; except that, where drain tile, trench drains or other foundation drainage systems present a hazard of contamination outside the treatment zone, treatment shall be performed in a manner that will not introduce termiticide into the drainage system.
3. Establish a horizontal barrier in the soil within 3' of the main foundation, under slabs, such as patios, walkways, driveways, terraces, gutters, etc. Treatment shall be performed before slab is poured, but after fill material or fill dirt has been spread.
4. Establish a vertical barrier in the soil around all critical areas, such as expansion and construction joints and plumbing and utility conduits, at their point of penetration of the slab of floor or, for crawl space construction, at the point of contact with the soil.

Reapply soil treatment solution to areas distributed by subsequent excavation or other construction activities following application.

END OF SECTION

RELATED DOCUMENTS:

Drawings and general provisions of Contract, including General and Supplementary Conditions and Division-1 Specification sections, apply to work of this section.

PART 1:

DESCRIPTION OF WORK:

The work required is that necessary to conduct the construction in accordance with the requirements the North Carolina Sedimentation Pollution Control Act of 1973 and the rules and regulations promulgated pursuant to the provisions of said act.

Related Work Specified Elsewhere:

Fertilizing, Seeding and Mulching: Section 02480
Erosion Control Narrative: Section 02401

Codes and Standards: North Carolina Sedimentation Pollution Control Act of 1973 and the Rules and Regulations promulgated pursuant to the provisions of said act.

Local County Soil Erosion and Sedimentation Control Ordinance.

In the event of conflict between the regulations listed above and the requirements of these specifications, the more restrictive requirements shall apply.

PART 2: PRODUCTS

PART 3: EXECUTION

GENERAL:

Construct temporary and permanent erosion control measures as shown on the plans and as directed by the Engineer. All permanent erosion control work shall be incorporated into the project at the earliest practicable time. Temporary erosion control measures shall be coordinated with permanent erosion control measures and all other work on the project to assure economical, effective, and continuous erosion control throughout the construction and post construction period and to minimize siltation of rivers, streams, lakes, reservoirs, other water impoundments, ground surfaces, or other property.

The Contractor shall finish grade all disturbed areas and disc the ground surface upon completion of the grading.

The finish grading shall be acceptable to the Owner.

END OF SECTION

GO TO NEXT PAGE

GO TO NEXT PAGE

GO TO NEXT PAGE

RELATED DOCUMENTS:

Drawings and general provisions of Contract, including General and Supplementary Conditions and Division-1 Specification sections, apply to work of this section.

GENERAL LANDSCAPE REQUIREMENTS AND ONE YEAR WARRANTY:

Redistribute stockpiled topsoil a minimum of 3" thick layer, to supplement that available for reuse at site.

Provide grown-in turf from seed, sod turf, and landscape plantings (trees, shrubs, flowers), maintain and warranty complete installation for one year following acceptance. Owner shall have final approval of tree and shrubs plantings materials.

All areas of finish grades disturbed or damaged by construction activities shall be completely restored to like new or original condition.

PRE-EMERGENT HERBICIDE TREATMENT:

Prior to permanent seeding, apply herbicide as recommended by the seed supplier, in accordance with published recommendations.

SEEDING PLAN:

PERMANENT SEEDING AFTER APRIL 15 AND BEFORE SEPTEMBER 15:

Seeding Mixture:

1. Centipede, applied at the rate of 10 lbs. Per acre.
2. Common Bermuda, applied at the rate of 100 lbs. Per acre.

PERMANENT SEEDING AFTER SEPTEMBER 15 AND BEFORE APRIL 15:

Seeding Mixture:

1. Centipede, applied at the rate of 10 lbs. Per acre.
2. Common Bermuda (unhulled), applied at the rate of 100 lbs. Per acre.
3. Annual Rye Grass, applied at the rate of 50 lb. Per acre.

SOD:

Provide centipede sod where indicated on Drawings.

SOIL AMENDMENTS

Apply 3000 lb. / acre ground agricultural limestone and 1,000 lb. / acre of 10-10-10 fertilizer.

MULCH

Use jute, excelsior matting, or other effective channel lining material to cover the bottom of channels, ditches, and swales as required to prevent erosion and promote turf establishment. Extend lining above the highest calculated depth of flow. On channel side slopes above this height, and in drainages not requiring temporary lining, apply 4000 lb. / acre grain straw by stapling netting over the top.

All other lawn areas shall be mulched with 2,000 lb. / acre grain straw, stitched into ground with a disc harrow with blades set straight

TURF ESTABLISHMENT, MAINTENANCE, AND SPECIAL RIGHT OF OWNER TO TAKE CORRECTIVE ACTION

Turf establishment and maintenance includes sufficient irrigation and frequent mowing to promote turf grow-in and to prevent the growth and proliferation of weeds. In addition, the contractor shall re-seed, re-fertilize and mulch immediately following erosion or other damage, which is to be expected. Should the Owner determine that the grounds in part or as a whole lack proper maintenance in accordance with this paragraph, the Owner or his designated agent (the Architect or Engineer) may provide written notice to the Contractor to take corrective action. If the Contractor does not respond with corrective action or otherwise in an acceptable manner to the Owner within five (5) calendar days, the Owner may, at his option, undertake such corrective action with his own or other forces, and deduct the full cost from the Contract amount of the Contractor.

PLANTING GENERAL LAWNS:

Where topsoil has been stripped, redistribute a minimum 3" layer of stockpiled topsoil, add specified soil amendments and mix thoroughly into top 4" of soil, tilling surface to a level, fine texture.

Cultivate to a depth of 6" in areas where topsoil has not been stripped, add specified soil amendments and mix thoroughly into top 4" of soil, tilling surface to a level, fine texture.

Grade and roll prepared lawn surface. Water thoroughly but do not create muddy soil condition.

Hydro-seed uniformly in two directions in the quantity recommended by the seed producer. Water thoroughly with fine spray.

Protect seeded areas against erosion by stitching mulch straw with a disc harrow with blades set straight. Immediately after seeding, protect the area against traffic or other use by erecting barricades as required until final acceptance.

Install sodding where indicated on Drawings. Irrigate as necessary for establishment and maintenance.

LANDSCAPE MATERIALS AND PLANTING:

Comply with detailed drawings and the AMERICAN STANDARD FOR NURSERY STOCK, ANSI Z60.1-1990. Plant materials shall be checked upon delivery to site and before planting in accordance with this standard, and any materials that do not meet specifications will be removed from the site. The contractor shall replace any dead or dying plant materials, or those failing to thrive, that are observed, following acceptance of 12 months install by Owner.

FINAL ACCEPTANCE:

Final Inspection and Acceptance: At the end of the turf establishment period, final inspection will be made upon written request at least 10 days prior to the anticipated date. Final acceptance will be based upon a full stand of turf of the species specified.

Turf establishment period shall be defined as minimum three mowing cycles, or as required to produce a stand of turf. Contractor is responsible for irrigation and mowing as required.

Re-planting: In areas which do not have a satisfactory stand of turf or sod, replace sod or replant, mulch, re-fertilize and irrigate within specified planting dates.

END OF SECTION

RELATED DOCUMENTS:

Drawings and general provisions of Contract, including General and Supplementary Conditions and Division-1 Specification sections, apply to work of this section.

PART 1: GENERAL

1.1 DESCRIPTION OF WORK

1. Provide all labor, materials, equipment and tools necessary for complete installation of synthetic grass safety surface. Surface shall meet the requirements of ASTM F1292-13, that states that the surface must yield both a peak deceleration of no more than 200 g's and Head Injury Criteria (HIC) value of no more than 1,0000 for a headfirst fall from the accessible height of the play equipment. System must be IPEMA certified and supported by test data that is less than 3 years executed.
2. The system shall consist of, but not necessarily be limited to, the following:
 - a. Synthetic grass consisting of fibers that are 1.125" long. Turf fiber construction consisting of 100% polyethylene monofilaments and texturized polyethylene thatch tufted to a 2-layer stabilized woven polypropylene fabric (primary backing), with a secondary backing (stitch binder) of DuraFlo. (XGrass® Luxury Rec synthetic turf).
 - b. Pad underlayment system consisting of porous closed cell composite materials. Thickness and density of panels shall be sufficient so that system meets the requirements of ASTM F1292-13. (SofPad™)
 - c. Synthetic Grass Infill, consisting of anti-microbial acrylic coated round silica particles, designed to provide the look, feel and performance of optimally maintained natural grass. (EnviroFill®)
 - d. ½" Screenings, ¾" clean aggregate, compacted 4" deep.
 - e. Synthetic grass shall be CPSIA compliant with valid supporting test documents.
 - f. Equivalent products by Astro Turf and TigerTurf are acceptable.

2.2 SUBMITTALS

1. Product Data: Submit manufacturer's product data, including installation instructions and subsurface instructions.
2. Shop Drawings, showing layout and product installation details.
3. Samples: Submit samples for synthetic grass, infill, pad underlayment.
4. Warranty: Submit manufacturer's standard 10-year warranty.

PART 2 – PRODUCTS

2.1 SYNTHETIC GRASS SAFETY SURFACE

1. Aggregate Base – Crushed angular hard stone, ¾" minus compactible stone (not clean) or clean stone with top layer of compacted fines. (Refer to Section 3.2.4).

2. Synthetic grass: 1.125" XGrass® Luxury Rec Synthetic Turf from XGrass, XGRASS.COM, Phone (877) 881-8477
 - a. Tufted Face Weight: 72oz/sy
 - b. Face Yarn Type: Polyethylene
 - c. Tufted Pile Height: 1.125"
 - d. Color: Summer Blend (Heat Block)
 - e. Construction: Broadloom tufted
 - f. Tufting Gauge: 1/4"
 - g. Tuft Bind: 13.1 lbs
 - h. Permeability: 405.7 inches/hour
 - i. Primary Backing: Stabilized dual layered woven polypropylene
 - j. Secondary Backing 10oz. DuraFlo
 - k. Total Product Weight: 91.8 oz/sy
 - l. Tufted Roll Width: 15 feet
 - m. Warranty: 10 Year
 - n. Manufactured in the USA, internationally manufactured products will not be accepted.
3. Pad Underlayment System: SofPad™ 100% recycled, non-contaminated, Post industrial cross-link, closed cell Polyethylene – polyolefin foam pad from XGrass.
 - a. Foam Type: Polyethylene – Polyolefin
 - b. Bulk Density: 5.0-8.0 lb/cu ft
 - c. Effective Size: 24 sq ft (net coverage)
 - d. Tensile Strength: 34-36
4. Synthetic Grass Infill: EnviroFill® from XGrass, Phone (877) 881-8477. Coating: Priority acrylic with Micoban®, iron oxide and chromium oxide.
 - a. Grain Shape: Hardness: 6-8 Mohs
 - b. Curvature: 0.7+
 - c. Specific Gravity: 1.76 g/cm³
 - d. Bulk Density: 100lb/cu ft
 - e. Uniform Coefficient: 1.10 to 1.40
 - f. Effective Size: .84-1.68 mm
5. Splicing Material: 1000 denier coated nylon (Cordural®) 12" wide minimum.
6. Adhesive: Synthetic Turf Adhesive (from XGrass)
7. Warranty: Provide Manufacture's standard 10-year warranty

PART 3 – EXECUTION

3.1 GROUND PERPARATION

1. General: The ground area to receive synthetic grass safety surface is indicated on the Drawings.
2. Leveling and Site Preparation: All organic material ad organic debris to be removed. Soil to be graded level and stabilized (compacted) 6-7" below grade, per site requirements. Compaction shall be done with mechanical compactors, including vibratory compactors, and/or powered tampers, and rollers.

3.2 BASE AND SYNTHETIC GRASS CONSTRUCTION

1. General: The area to be smooth and graded to allow to proper drainage. Refer to engineered grading plan if available. The overall grade of the playground is not to exceed 3%.
2. Nailor Board: Installation of pressure treated or composite board per site requirements.

- a. Concrete edges: Nailer board attached directly to vertical concrete edge with a Tapcon hardware situated $\frac{3}{4}$ " below concrete grade.
 - b. Non-concrete edges: Nailer board installed with round, steel stake, 3 per 10" board. Top of nailer boards to be situated $\frac{3}{4}$ " below grade.
3. Optional layer of geotextile fabric.
 4. Compacted Aggregate Base: Place 4" of $\frac{3}{4}$ " clean aggregate base and $\frac{1}{2}$ " of screening as leveling layer compactors, and /or powered tampers, and rollers.
 5. Underlayment Pad: Lay underlayment pas with seam staggered, trimming edge to fit flush against the nailer board.
 6. Synthetic Grass: place turf and cut to fit configuration as shown on Drawings. Splice seams, all seams must be attached with splicing film / fabric and adhesive as approved by the manufacturer for this type of installation of their product.
 7. Anchoring / Edging: Edges of turf will be secured to nailer board perimeter.
 8. Infill: Apply layers of synthetic grass infill evenly with a drop spreader and broom the turf fibers with stiff bristle broom to stand fibers up and allow infill to settle into the fine bottom. Broom in infill round quartz silica sand approximately 3 pounds per square foot.

END OF SECTION

RELATED DOCUMENTS:

Drawings and general provisions of Contract, including General and Supplementary Conditions and Division-1 Specification sections, apply to work of this section.

PART 1: GENERAL

DESCRIPTION OF WORK:

Extent of portland cement concrete paving includes concrete sidewalks, curbs and gutters, as shown on Drawings.

Prepared subbase is specified in Section 02200.

Concrete and related materials are specified in Section 03200.

QUALITY ASSURANCE:

Codes and Standards: Comply with NCDOT Regulations if more stringent than herein specified.

SUBMITTALS:

Furnish samples, manufacturer's product data, test reports, and materials' certifications as required in referenced sections for concrete and joint fillers and sealers.

Install sample section of concrete sidewalk for review and approval by Architect. Mockup sample to include full construction features required by Drawings, including expansion joints and sealants, and control joints.

JOB CONDITIONS:

Traffic Control: Maintain access for vehicular and pedestrian traffic as required for other construction activities.

Utilize flagmen, barricades, warning signs and warning lights as required.

PART 2: PRODUCTS

MATERIALS:

Forms: Steel, wood, or other suitable material of size and strength to resist movement during concrete placement and to retain horizontal and vertical alignment until removal. Use straight forms, free of distortion and defects.

Use flexible spring steel forms or laminated boards to form radius bends as required.

Coat forms with a non-staining form release agent that will not discolor or deface surface of concrete.

Concrete Materials: Comply with requirements of applicable Division - 3 Sections for concrete materials, admixtures, bonding materials, curing materials, and others as required.

Welded Steel Wire Fabric: ASTM A185 Plain Type; in flat sheets; unfinished. Rolled WWF shall not be acceptable for use on this job.

Expansion Joint Materials: Bituminous Fiber, 1/2" thick, complying with NCDOT Spec. Section 928-1 and Section 420-12.

Liquid-Membrane Forming Curing Compound: Complying with ASTM C 309, Type I, Class A unless other type acceptable to Engineer. Moisture loss not more than 0.055 gr. / sq. cm. when applied at 200 sq. ft. / gal.

Detectable Tactile Warning Surfaces: Vitrified polymer composite panels, cast into concrete. Dark contrasting color. "Armor-Tile" as manufactured by Engineered Plastics or equivalent. Comply with all ADA and NC Accessibility code requirements.

CONCRETE MIX, DESIGN AND TESTING:

Comply with requirements of applicable Division - 3 Sections for concrete mix design, sampling and testing, and quality control, and as herein specified.

Design mix to produce normal-weight concrete consisting of portland cement, aggregate, water-reducing or high-range water-reducing admixture (super - plasticizer), air-entraining admixture and water to produce the following properties:

Compressive Strength: 3,000 psi, minimum at 28 days, unless otherwise indicated.

Slump Range: Not greater than 4".

Air Content: 5 % - 8%.

PART 3: EXECUTION

SUBSURFACE PREPARATION:

Remove loose material from compacted subbase surface immediately before placing aggregate base course. No aggregate base course shall be placed until the foundation has been inspected and approved by the Engineer. Proof-rolling may be required depending on condition of subbase.

Place aggregate base course material on prepared subgrade in layers of uniform thickness. Grade the base course evenly to thickness indicated on drawings and compact before placing concrete.

FORM CONSTRUCTION:

Set forms to required grades and lines, rigidly braced and secured. Install sufficient quantity of forms to allow continuous progress of work and so that forms can remain in place at least 2 hours after concrete placement.

Check completed formwork for grade and alignment to following tolerances:

Top of forms not more than 1 / 8" in 10'.

Vertical face on longitudinal axis, not more than 1/4" in 10'.

Clean forms after each use, and coat with form release agent as often as required to ensure separation from concrete without damage.

REINFORCING

Chairs, Bolsters, Bar Supports, Spacers: Sized and shaped for strength and support of reinforcement during concrete placement conditions, including load bearing pads.

CONCRETE PLACEMENT:

General: Comply with requirements of Division - 3 Sections for mixing and placing concrete, and as herein specified.

Do not place concrete until subbase and forms have been checked for line and grade. Moisten subbase if required to provide a uniform dampened condition at time concrete is placed. Do not place concrete around manholes or other structures until they are at required finish elevation and alignment.

Place concrete using methods which prevent segregation of mix. Consolidate concrete along face of forms and adjacent to transverse joints with internal vibrator. Keep vibrator away from joint assemblies, reinforcement, or side forms. Use only square-faced shovels for hand-spreading and consolidation. Consolidate with care to prevent discoloration of reinforcing, dowels, and joint devices.

Deposit and spread concrete in a continuous operation between transverse joints, as far as possible. If interrupted for more than 1/2-hour, place a construction joint.

Drop top of curb as shown in details of plans at all radii of intersections, to allow construction of handicapped ramps and sidewalks.

Curbs and Gutters: Automatic machine may be used for curb and gutter placement at Contractor's option. If machine placement is to be used, submit revised mix design and laboratory test results which meet or exceed minimums specified. Machine placement must produce curbs and gutters to required cross-section, lines, grades finish, and jointing as specified.

JOINTS:

General: Construct expansion, weakened-plane (contraction), and construction joints true-to-line with face perpendicular to surface of concrete. Construct transverse joints at right angles to the centerline, unless otherwise indicated.

When joining existing structures, place transverse joints to align with previously placed joints, unless otherwise indicated.

Exterior Concreted Walks: Provide all concrete walk surfaces with a concrete walk 1/2" tooled expansion joints at 30' centers maximum and sawcut weakened-plane (contraction) joints at 5' centers maximum. Pour sample for Architect approval.

Weakened-Plane (Contraction) Joints: Provide sawcut weakened-plane (contraction) joints, sectioning concrete sidewalks at 5' intervals. Sawcut weakened-plane joints for a depth equal to at least 1/4 concrete thickness, as follows:

Sawcut joints at concrete walks as soon as concrete has sufficient strength to prevent spalling of the joint due to the action of the saw. But in no case greater than 4 hours after initial placement of the concrete. Concrete walk sawcut joints shall not be filled with joint filler.

Tooled Joints: Form tooled joints in fresh concrete by grooving top portion with a recommended cutting tool and finishing edges with a jointer. Remove tooling marks.

Construction Joints: Place tooled construction joints at end of placements and at locations where placement operations are stopped for a period of more than 1/2-hour, except where such placements terminate at expansion joints.

Construct joints as shown or, if not shown, use standard metal keyway-section forms.

Locate expansion joints at 90' o.c. for each curb and gutter section and 30' o.c. for each sidewalk section unless otherwise indicated, and at beginning and end of all curb and gutter radii. Connections with rigid objects including existing curb and gutter and catch basins.

Extend joint fillers full-width and depth of joint, and not less than 1/2" or more than 1" below finished surface where joint sealer is indicated. If no joint sealer, place top of joint filler flush with finished concrete surface.

Furnish joint fillers in one-piece lengths for full width being placed, wherever possible. Where more than one length is required, lace or slip joint filler sections together.

Protect top edge of joint filler during concrete placement with a metal cap or other temporary material. Remove protection after concrete has been placed on both sides of joint.

Fillers and Sealants: Comply with manufacturer's requirements for preparation of joints, materials installation, and performance. Place at all curb and gutter template joints, curb-to-walk transition joints, concrete walk expansion joints, tooled concrete walk construction joints. Joint filler not required at 5' O.C. sawcut weakened-plane contraction joints.

CONCRETE FINISHING:

After striking-off and consolidating concrete, smooth surface by screening and floating. Use hand methods only where mechanical floating is not possible. Adjust floating to compact surface and produce uniform texture.

After floating, test surface for trueness with a 10' straight edge. Distribute concrete as required to remove surface irregularities, and refloat repaired areas to provide a continuous smooth finish.

Work edges of slabs, gutters, back top edge of curb, and formed joints with an edging tool, and round to 1/2" radius, unless otherwise indicated. Eliminate tool marks on concrete surface.

After completion of floating and troweling when excess moisture or surface sheen has disappeared, complete surface finishing, as follows:

Provide all concrete walk surfaces with a unidirectional fine broom finish. Pour sample for Architect approval.

Broom Finish, by drawing a fine-hair broom across concrete surface, perpendicular to line of traffic. Repeat operation if required to provide a fine line texture acceptable to Engineer.

Do not remove forms for 24 hours after concrete has been placed. After form removal, clean ends of joints and point-up any minor honey combed areas. Remove and replace areas or sections with major defects, as directed by Engineer.

CURING:

Protect and cure finished concrete paving, complying with applicable requirements of Division - 3 Sections. Use membrane-forming curing and sealing compound or approved moist-curing methods.

REPAIRS AND PROTECTIONS:

Repair or replace broken or defective concrete, as directed by Engineer.

Drill test cores where directed by Engineer, when necessary to determine magnitude of cracks or defective areas. Fill drilled core holes in satisfactory pavement areas with portland cement concrete bonded to pavement with epoxy adhesive.

Protect concrete from damage until acceptance of work. Exclude traffic from pavement for at least 14 days after placement. When construction traffic is permitted, maintain pavement as clean as possible by removing surface stains and spillage of materials as they occur.

Sweep concrete and wash free of stains, discolorations, dirt and other foreign material just prior to final inspection.

END OF SECTION

RELATED DOCUMENTS:

Drawings and general provisions of Contract, including General and Supplementary Conditions and Division-1 Specification sections, apply to work of this section.

PART 1: GENERAL

DESCRIPTION OF WORK:

The extent of work under this item includes the placement of aggregate base course and asphalt concrete pavement.

Asphalt concrete paving shall also mean asphalt paving, or bituminous concrete as may be used in other sections of the specifications or drawings.

SUBMITTALS:

Material Certificates: Asphalt Concrete Paving:

Provide two copies of materials certificates signed by the material producer and the Contractor, and notarized, certifying that each material item complies with, or exceeds, specified requirements.

Job Mix Formula: Provide two copies of the proposed job mix formula at least 10 days prior to beginning work. This formula shall be approved by NCDOT for the type of pavement specified. Contractor shall, at his own expense, take whatever measures are necessary in order to obtain said approval prior to beginning work of have a mix design prepared by an approved Testing Lab.

SITE CONDITIONS:

Weather Limitations: Construction shall be conducted in accordance with the weather limitations given in the applicable sections of "Standard Specifications for Roads and Structures" as issued by N. C. Department of Transportation. No asphalt concrete shall be placed when the ambient temperature is less than 40 degrees F (4°C.) in the shade away from artificial heat.

Grade Control: Establish and maintain required lines and elevations as necessary to match existing grades and / or proposed grades on the drawings.

LIQUID ASPHALT PRICE ADJUSTMENT:

Asphalt shall be bid based on the FOB binder price in effect on Bid Date, per ton. Adjustments to the contract will be made + / - in accordance with NCDOT Section 620-5 "Basis of Payment" rules.

PART 2: PRODUCTS

MATERIALS:

General: Use locally available materials and gradations, which exhibit a satisfactory record of previous installations.

Aggregate Base Course: Aggregate meeting the requirements of Section 910-1, Paragraph (a) of "Standard Specifications for Roads and Structures" by NCDOT.

Asphalt Concrete Base Course Type B 25.0 B: Materials meeting the requirements of Section 645 of "Standard Specifications for Road and Structures" as issued by NCDOT.

Asphalt Concrete Intermediate Course Type I 19.0.0 B: Materials meeting the requirements of Section 645 of "Standard Specifications for Road and Structures" as issued by NCDOT.

Asphalt Surface Course, Type S-9.5C: Materials meeting the requirements of Section 645-2 and 3 of "Standard Specifications for Road and Structures" by NCDOT. Apply as indicated on Drawings

Tack Coat: Material meeting the requirements of Section 605-2 of "Standard Specifications for Roads and Structures" as issued by NCDOT. Only on existing asphalt to be overlaid.

Striping: Glidden "Romark" traffic marking paint, or approved equivalent. Apply full 2-coat thickness for all striping and graphics, and symbols. Allow new asphalt to cure sufficiently in accordance with manufacturer's written application instructions. Allow manufacturer's specified cure time between coats.

All markings in NCDOT right-of-ways to be thermoplastic as approved by NCDOT.

Asphalt Seal Coat: Mineral reinforced asphalt emulsion blended with polymers, 58% to 63% solids, equivalent to Polymer Modified MasterSeal. Apply per manufacturer's instructions and specifications and in compliance with ASMA Standard Specifications.

Recycled Rubber Speed Bump: Where indicated on Drawings provide 19'-0" long x 14" wide x 2.5" high Premium Recycled Rubber Speed Bumps, as manufactured by TreeTop Products (866) 734-0605. Install in accordance with written manufacturer's installation instructions.

Features Include:

1. Molded-in cat eye reflectors and Bright Yellow striping
2. Manufactured for surface mounting to pavements
3. Reduces speeds to 2-5 mph
4. Lag Bolt and Washers hardware as required for pavement types installations
5. With speed bump end caps
6. 15-year warranty against breakage

PART 3: EXECUTION

GENERAL:

Install the aggregate base course, asphalt surface course, prime coat and tack coat in accordance with the applicable provisions of "Standards Specifications for Roads and Structures" as issued by the North Carolina Department of Transportation.

Provide milling and/or wedging of existing asphalt surfaces at asphalt paving modifications and tie-ins as necessary to meet indicated grades of modified areas.

SUBGRADE:

Shape surface of areas under base course to line, grade and cross-section shown on drawings, with finish surface not more than 1/2" above or below the required subgrade elevation.

Patches in driveways and roadways shall be graded to depth required to match existing pavement or to provide minimum pavement specified.

Maintain a uniform surface on the subgrade until the placement of aggregate base course is complete.

Provide a proof rolling of the compacted subgrade with a heavy roller or loaded dump truck (+25 tons) in the presence of the Engineer. The proof rolling shall be covered by the wheels of the proof roller operating at a speed between 2 and 3 miles per hour.

Any areas that rut or pump excessively shall be allowed to dry or shall be undercut and backfilled with select backfill or coarse aggregate base course as directed by the Engineer.

After undercut and backfill operations are complete, a final proof rolling of the undercut areas will be performed in the presence of the Engineer.

AGGREGATE BASE COURSE:

Place base course material on prepared subgrade in layers of uniform thickness. Subgrade shall be inspected and accepted for placement of base course by Engineer as described above. Grade the base course evenly and compact to 100%. The thicknesses indicated on drawings are compacted thickness.

Maintain a uniform surface on the base course until the placement of the asphalt surface course is complete.

Provide a proof rolling of the compacted aggregate base course with a heavy roller or loaded dump truck (+25 tons) in the presence of the Engineer. The proof rolling shall be covered by the wheels of the proof roller operating at a speed between 2 and 3 miles per hour.

Any areas that rut or pump excessively shall be allowed to dry or shall be undercut and subgrade replaced with select backfill or coarse aggregate base course as directed by the Engineer.

After undercut and backfill operations are complete, a final proof rolling of the undercut areas will be performed in the presence of the Engineer, and Owners representative.

TACK COAT:

Tack Coat shall be applied to contact surfaces of previously constructed asphalt or portland cement concrete and surfaces abutting or projecting into asphalt concrete pavement. All application of tack coat shall be in conformance with Section 605 of the N. C. Highway Specifications for Roads and Structures latest revision.

Tack coat shall be uniformly applied at a rate of 0.02 to 0.05 gallons per square yard. No more tack coat material shall be applied than can be covered with base, binder, or surface course during the following day's operations. No base, binder or surface mixture shall be deposited thereon until the tack coat has sufficiently cured to properly receive paving.

All exposed surfaces, not intended to contact paving, shall be protected sufficiently to prevent tack coat from being tracked or splattered on said surfaces. After the tack coat has been applied, it shall be protected until it has cured for a sufficient length of time to prevent it from being picked up by traffic.

PLACING ASPHALT CONCRETE PAVEMENT:

Place asphalt concrete pavement in as continuous as operation as possible. The Contractor shall spread the materials to uniform density and strike a smooth finish true to cross-section and free from inequalities. Spread mixture at minimum temperature of 225 degrees F. Place each course in the required amounts, so that when compacted, they will conform to the indicated grade, cross section, and thickness. All seams or joints are to be raked smooth prior to rolling.

Provide joints between old and new pavements and between successive days' work for continuous bond between adjoining work. Clean contact surfaces and apply tack coat.

Rolling: Begin rolling when asphalt concrete mixture will bear roller weight without excessive displacement. Repair surface defects with hot asphalt concrete material as rolling progresses. Cut out and patch defective areas and roll to blend with adjacent satisfactory paving. Continue rolling until maximum density is attained and roller marks eliminated.

Protect paving from damage and vehicular traffic until asphalt concrete mixture has cooled and attained its maximum degree of hardness.

FIELD QUALITY CONTROL:

GENERAL:

Test the in-place asphalt concrete courses for compliance with requirements for thickness, compacted density and surface smoothness. Repair or remove and replace unacceptable paving as directed by the Engineer, or Owner.

Thickness: In-place thickness will not be acceptable if exceeding following allowable variation from required thickness:

Course Aggregate Base Course: 1/2", plus or minus.

Surface Smoothness: Test finished surface of each asphalt concrete course for smoothness, using 10' straight edge applied parallel with, and at right angles to center line of paved area. Surfaces will not be acceptable if exceeding the following tolerances for smoothness:

- Wearing Course Surface: 1/8"
- Check surfaced areas at intervals as directed by the Engineer.

END OF SECTION

RELATED DOCUMENTS:

Drawings and general provisions of Contract, including General and Supplementary Conditions and Division-1 Specification sections, apply to work of this section.

PART 1 - GENERAL

- 1.1 All materials and installation methods shall be in accordance with these plans and specifications and applicable AWWA Standards and the AUTHORITY HAVING JURISDICTION (AHJ) standards and specifications. The Contractor shall obtain from the Owner certificate of approval for the substitution of any material other than those specified. Excavation & backfilling shall conform to TRENCHING AND BACKFILLING FOR UTILITIES.
- 1.2 Current specifications of the American Society for Testing Materials (ASTM) and the American National Standards Institute (ANSI) shall apply in all cases where material is covered by an item in these specifications, and all material used under this contract shall conform fully to these current specifications or be removed from the job at the direction of the Owner. Failure of the Owner to condemn material on preliminary inspection shall not be grounds for acceptance if future defects are found.
- 1.3 Detail or shop drawings of valves and tapping sleeves must be approved by the Engineer prior to installation, or approval of payment for same.
- 1.4 It shall be the contractor's responsibility to notify the Owner and the AHJ at least 24 hours in advance of beginning any construction work on any portion of this project.
- 1.5 Preconstruction Conference: Prior to commencing any water extension construction work, the Department Engineer shall be contacted to schedule a preconstruction conference. No construction shall occur until after the preconstruction conference is held.
- 1.6 Contractor shall be responsible for verifying all elevations, dimensions, locations and sizes of existing facilities in the field prior to construction or ordering materials.
- 1.7 Pipe installation shall be performed only in the presence of the AHJ's Representative, except as authorized by the AHJ.
- 1.8 Backfilling shall be performed only with the approval of a AHJ's Representative.
- 1.9 The Contractor shall construct and maintain all detours, crossings and temporary approaches that may be required during construction. Maintenance shall be in accordance with the applicable features of Section 150 of the N.C. Department of Transportation Standard Specifications.
- 1.10 All PVC water main shall be installed with Detectable marking tape shall be installed in accordance with Section 3. Tape shall be three (3) inches in width with a minimum thickness of 0.5 millimeters (minimum solid center foil thickness of 0.35 millimeters). Color of the tape shall be blue meeting the American Water Works Association color code. Tape shall read: "Caution – Buried Water Line Below". Tape shall be manufactured by Lineguard, Inc., Pro-Line Safety Products Co., Empire Level Mfg. Corp., or approved equal.

1.11 Property Protection:

- 1.11.1 Trees, fences, poles and all other property shall be protected unless their removal is authorized, and any property not authorized for removal, but damaged by the Contractor shall be restored by the Contractor to the Owner's satisfaction.
- 1.11.2 Signs, mailboxes and other items which must be removed to facilitate construction shall be replaced in a condition equal or better than condition prior to removal. Replacement shall occur immediately following backfill of the trench at the location of each item removed.
- 1.11.3 All existing drainage shall be maintained at all times on the Project. Any drainage swales, ditches, culverts, etc. blocked by construction activities shall be reopened at the end of the day before leaving the job site.

1.12 Encroachment Contracts and Permits:

- 1.12.1 Prior to actual construction, the Owner shall acquire the necessary encroachments from NCDOT for installations. When working inside the rights-of-way of State system roads for highways, the Contractor shall acquire the necessary permits for his work.
- 1.12.2 The Contractor shall be responsible for securing all other local and state permits required for the utility construction.
- 1.12.3 Open cut shall be used for excavation of all water mains unless written permission of the Owner is given, or as specified by the encroachment agreement with the N.C. Department of Transportation.

1.13 Record Drawing: An updated record drawing shall be prepared by the contractor and submitted to the Engineer as a condition of approval for any pay request which includes pay items for water and/or sewer improvements. Record drawings shall be prepared by and bear the seal and signature of a Professional Engineer or Registered Land Surveyor.

1.14 Guarantee: The Contractor shall guarantee all material, equipment, and workmanship for a period of one year after final acceptance by the Owner and the AHJ. Inspection may be made by AHJ within the one-year warranty. The Contractor shall make any and all necessary repairs to the system within this his one-year warranty period at no additional cost to the Owner or the AHJ.

Before the guarantee period shall begin, the record drawings and other relevant information shall be approved and the owner shall receive a letter of acceptance from the AHJ for the water.

PART 2 - MATERIALS

- 2.1 PVC Water Mains - 4" through 12": All mains 4" through 12" shall be polyvinyl chloride pipe meeting the requirements of the latest edition of AWWA C-900. The pipe shall be rated at 150 psi, and SDR 18 with integral bell and spigot joints. Outside diameter of the pipe shall be the same as cast iron. Joints shall be elastomeric-gasket type designed to accommodate up to 3 degrees of axial deflection without adverse consequences. Pipe shall be furnished in nominal 20 foot lengths
- 2.2 PVC Water Mains to 3": All water mains to 3" PVC water main shall be Class 200 SDR 21 conforming to ASTM D1784 and ASTM D2241 with "push-on" joints. Fittings shall be Schedule 80 PVC with solvent weld joints. Pipe shall be furnished in nominal twenty-foot (20') lengths. All pipe shall bear the NSF logo.
- 2.3 Ductile Iron Pipe: Ductile iron pipe for water mains shall be manufactured in conformance with AWWA C151 and shall be cement mortar lined with an asphaltic coating in accordance with AWWA C104. The exterior of the pipe shall be bituminous coated in accordance with AWWA C151. The minimum thickness Class of pipe shall be Class 50. Pipe shall be furnished in nominal 18 to 20 foot lengths. Pipe joints for ductile iron pipe shall be "push-on" unless the additional pipe deflection allowed by mechanical joints is necessary or other considerations dictate the use of mechanical joints. The joints for ductile iron pipe shall conform to AWWA Standard C111 revision (ANSI A21.11).

Polyethylene encasement shall be applied to all underground ductile iron pipe and fitting installations. Material and installation procedures shall be in accordance with ANSI/AWWA C105/A21.5-88.

- 2.4 Gate Valves: Gate Valves shall conform to requirements of the latest version of AWWA Specification C-509 for resilient seated gate valves. The valve body shall be ASTM A-126 Class B cast iron. All interior valve parts and surfaces shall be of corrosion resistant materials or have an epoxy coating sufficient to prevent corrosion. Such coating shall be recognized by the AWWA for potable water use. Exterior valve parts and surfaces shall be epoxy coated or have the Standard AWWA coating. The valves shall open counterclockwise and have non-rising stem operation with 2-inch square operating nuts. The maximum number of turns required to fully open or close the valve shall equal three times the pipe diameter plus two. The stem shall be of corrosion resistant material and have "O" ring seals. Valve shall provide zero leakage at a working pressure of 200 psi in either direction of line flow. Valves shall have flange connections conforming to ANSI B16.1. Class 125 or mechanical joints conforming to AWWA C-111. Valves shall be manufactured by Clow, American Flow Control, or Mueller.
- 2.5 Ball Valves (2"): Ball valves for two-inch mains and services shall be bronze body with tee head. The turn required to travel from fully closed to fully open position shall be 90 degrees. Ball valves shall be Hayes 4300, A.Y. McDonald 6101W, Ford B11-777, Mueller B-20283or approved equal.

2.6 Valve Boxes

Valves 2" through 10" - Valve boxes shall be of cast iron suitable for H-20 loading. The manufacturer's name and part number shall be cast into each component of the box. The

box shall be of the telescoping (slip) type consisting of a base section, center extensions as necessary, and a top section with a cover marked "WATER". Sections shall be selected and installed such that a minimum of four inches (4") of future adjustment (upward and downward) is possible without section removal or replacement and without the use of adapters. Valve boxes and extensions shall be either of the following:

- Charlotte Pipe and Foundry: UTL-274 (valve boxes) and UTL-281 (extensions).
- Tyler Pipe: 6855 Series (valve boxes and extensions). Lid shall be 5-1/4" Drop Lid having a minimum of 1-1/2" deep skirt.
- East Jordan Iron Works Global Cast: G-8472 Slip-Type Valve Box Series

Valve boxes shall be installed in accordance with the Standard Details.

2.6.1 Valves 12" and Larger – Valve box shall consist of an East Jordan Iron Works – 157801 frame and cover with a valve box bottom and extensions, as needed in accordance with Section 7.3.4.1. Installation shall be in accordance with the Standard Details.

2.7 Fittings: Tees, elbows and other fittings for PVC SDR 21, PVC C-900 pipe and ductile iron pipe shall be of ductile iron. Standard dimension fittings or compact fittings may be used in accordance with the requirements of this Section. The interior of all fittings shall be cement mortar lined with an asphaltic coating in accordance with AWWA Standard C-104 (ANSI 21.4). The exterior of all fittings shall have a one (1) mil bituminous coating in accordance with AWWA Standards C-110 (ANSI A21.10).

Compact fittings shall be ductile iron with either push-on or mechanical joints in accordance with ANSI/AWWA C153/A21.53-84. Cement lining and asphaltic coating shall be provided in accordance with ANSI/AWWA C104/A21.4.

Standard dimension fittings for PVC SDR 21, PVC C-900 pipe and ductile iron pipe shall be of ductile iron with either "push-on" joints or mechanical joints. The fittings shall comply with all requirements of AWWA Standard C-110 (ANSI A21.10). Shall be designed for a minimum working pressure of 150 psi plus 100-psi surge pressure.

2.8 Restraint Devices

2.8.1 Restraint devices for use on PVC SDR 21, ductile iron and C-900 PVC "push-on" joints shall be constructed of high strength ductile iron, ASTM A536, Grade 65-45-12 and shall incorporate machined serrations on the inside diameter to provide positive restraint, exact fit, full circle contact and support of the pipe in an even and uniform manner. Bolts and connecting hardware shall be of high strength, low alloy material in accordance with ANSI/AWWA C111/A21.11, latest revision thereof. All devices shall have a safety factor of no less than 2:1 at the full rated pressure of the pipe on which it is installed. They shall be UL listed and Factory Mutual approved. Restraining devices shall be Uni-Flange Block Buster Series 1390-C, Star Pipe Products Allgrip series 3600 and Pipe Restrainers Series 1200S, or approved equal.

- 2.8.2 Restraint devices for use on mechanical joint to PVC SDR 21 and C-900 PVC, shall be constructed of high strength ductile iron, conforming to the requirements of ASTM A536, Grade 65-45-12, and shall incorporate machined serrations on the inside diameter to provide positive restraint, exact fit, full circle contact and support of the pipe in an even and uniform manner. Bolts and connecting hardware shall be of high strength low alloy material in accordance with ANSI/AWWA C111/A21.11, latest revision thereof. All devices shall have a safety factor of no less than 2:1 at the full rated pressure of the pipe on which it is installed. They shall be UL listed and Factory Mutual approved. Restraining devices shall be Uni-Flange Series 1500, Star Pipe Products, Allgrip Series 3600, Romac Industries, Inc GripRing or approved equal.
- 2.8.3 Restraint devices for use on mechanical joint ductile iron, shall be constructed of high strength ductile iron, conforming to the requirements of ASTM A536, Grade 65-45-12, and shall incorporate machined serrations on the inside diameter to provide positive restraint, exact fit, full circle contact and support of the pipe in an even and uniform manner. Bolts and connecting hardware shall be of high strength low alloy material in accordance with ANSI/AWWA C111/A21.11, latest revision thereof. All devices shall have a safety factor of no less than 2:1 at the full rated pressure of the pipe on which it is installed. They shall be UL listed and Factory Mutual approved. Restraining devices shall be Uni-Flange Series 1300-C, Star Pipe Products, Allgrip Series 3600, Romac Industries, Inc. GripRing or approved equal.
- 2.8.4 Locked hydrant tees and fittings for fire hydrants shall meet the requirements of AWWA Standard C-111 (ANSI A21-11). Locked tees shall be as manufactured by American Cast Iron Pipe Company, Clow, U.S. Pipe, or approved equal.
- 2.8.5 Bolted Couplings for PVC SDR 21 and PVC C-900 pipe and ductile iron pipe shall be constructed of a center sleeve and end rings of ductile iron in accordance with ASTM A536. Bolts and nuts shall be of high strength, low alloy steel per ASTM A242 and AWWA C-111. Center sleeve and end rings shall have a paint finish coat. Couplings shall be Ford Style FC1, Romac 501 Series, Smith Blair 441, or JCM 201.
- 2.9 Fire Hydrants: Hydrants shall be in accordance with AWWA Standard C502, latest revision thereof, suitable for an operating pressure of not less than 150 pounds per square inch and shall have a traffic breakable feature (safety flange and stem coupling), dry top, sealed lubrication reservoir and a main valve which is held closed with pressure. The hydrant body shall be cast iron with "O" ring seals and bronze threads on the seat ring and drain ring, and shall have two (2) 2 1/2-inch nozzles with caps having National Standard threads and one (1) 5-inch nozzle with a factory fitted Storz connection and cap. The hydrant main valve shall be a minimum of 5-1/4 inches in diameter. All continuously wetted hydrant parts and surfaces shall be of corrosion resistant materials or be epoxy coated with epoxy recognized by AWWA for potable water use. The epoxy coating shall be of a color other than black (unless the word "epoxy" is stenciled on the base) to permit distinction between standard and epoxy coatings to be made easily. Hydrants shall be American Darling B-84-B, Mueller A-423 or Clow Medalion.

The inlet shoe for fire hydrant shall have a six-inch (6") inside diameter and shall be cast or ductile iron with mechanical joint fittings in accordance with AWWA Standard C110.

- 2.10 Tapping Sleeves - Tapping sleeves shall be all stainless steel body and flange with a full circumferential gasket, or ductile iron body, mechanical joint designed to accommodate a minimum operating pressure of 150 pounds per square inch. All tapping sleeves shall be pressure tested prior to tapping the main. Stainless steel tapping sleeves shall be Ford Model FAST, JCM Model 432, Mueller Model H304 or Romac Model SST. Ductile iron body, mechanical joint sleeves shall meet the requirements of Section 7.2.3 of this Manual.
- 2.11 Tapping Valves - Tapping valves shall conform to the requirements of the latest revision of AWWA Specification C-509 for resilient- seated gate valves. The valve body shall be ASTM A-126 Class B cast iron. All internal valve parts and surfaces shall be of corrosion resistant materials or have an epoxy coating sufficient to prevent corrosion. Such coating shall be recognized by the AWWA for potable water use. Exterior valve parts and surfaces shall be epoxy coated or have the Standard AWWA coating. The valves shall open counterclockwise and have non-rising stem operation with a two-inch square operating nut. The maximum number of turns required to fully open or close the valve shall equal three times the pipe diameter plus two.

The stem shall be of corrosion resistant material and have O-ring seals. Valves shall provide zero leakage at a working pressure of 200 psi in either direction of line flow. Valves shall have a flange connection conforming to ANSI B16.1 Class 125 and a mechanical joint conforming to AWWA C-111. Valves shall be manufactured by Mueller, Clow or American Flow Control. Tapping valves shall be installed and pressure tested prior to tapping the water line.

- 2.12 Steel Encasement Pipe: Steel encasement pipe shall be spiral welded or smooth wall seamless, consisting of grade "B" steel with a minimum yield strength of 35,000 psi and manufactured in accordance with ASTM A139 and A283. The pipe thickness shall be in accordance with the requirements of the right-of-way owner, but in no case less than that shown in the following table. The ends shall be beveled and prepared for field welding at the circumferential joints.

MINIMUM WALL THICKNESS FOR STEEL ENCASEMENT PIPE

<u>NOMINAL DIAMETER IN INCHES</u>	<u>MINIMUM THICKNESS IN INCHES</u>
4- 12 3/4	0.188
14	0.219
16-18	0.250
20	0.281
22	0.312
24	0.344
26	0.375
28-30	0.406
32	0.438
34-36	0.469
38-42	0.500

The encasement pipe shall be uncoated inside and out unless required otherwise by the right-of-way owner or the AHJ.

Encasement pipe and joints shall be of leak proof construction, capable of withstanding design loading. The inside diameter of the encasement pipe shall be at least 2 inches greater than the largest outside diameter of the carrier pipe, joints or couplings, for carrier pipe less than 6 inches in diameter; and at least 4 inches greater for carrier pipe 6 inches and larger in diameter. It shall, in all cases, be great enough to allow the carrier pipe to be removed subsequently without disturbing the casing pipe or roadbed. Engineer to verify clearance between carrier pipe and encasement pipe.

- 2.11 Backflow Prevention: Control assemblies such as reduced pressure principal assemblies, double check valve assemblies and double detector check valve assemblies shall be limited to those approved by the Bertie Co. Regional Water System and the Foundation for Cross-Connection Control and Hydraulic Research, University of Southern California. RPZ or RPDA shall be Watts 909, Wilkins 375, or Febco 860 or approved equal.

PART 3 - CONSTRUCTION METHODS

- 3.1 GENERAL: Installation of the water main shall be in conformance with the latest AWWA Standards and the specific recommendations of the pipe manufacturer. Before any installation is begun, the contractor shall notify NC One Call, at least 48 hours prior to commencing construction in order that existing utilities in the area may be flagged or staked. The contractor shall be responsible for damage to any existing overhead and underground utility systems.

3.2 HANDLING AND STORING MATERIALS:

- 3.2.1 The Contractor shall be responsible for the shipping and storing of all water main materials. Any material which is damaged or defective shall be replaced by the Contractor at his own expense.
- 3.2.2 The loading and unloading of all pipe, valves, hydrants, manholes and other accessories shall be in accordance with the manufacturer's recommended practices and shall at all times be performed with care to avoid any damage to the material.

The Contractor shall locate and provide the necessary storage areas for materials and equipment. If private property is being used for storage areas, Contractor must have the written consent from the property owner.

- 3.2.3 All materials once on the job site shall be stored in accordance with the manufacturer's recommendations. All PVC water pipe shall be protected from the sun's ultra violet rays if stored on the job site longer than 20 days. The type of protective cover for all plastic pipe material shall be approved by the Owner prior to use.
- 3.2.4 All valves and hydrants shall be stored so that they are protected from freezing. All pipe shall be kept free of dirt and other debris. Any damage relating to the coating of the various materials for water mains shall be repaired in a manner approved by the Owner.
- 3.2.5 The Contractor shall be responsible for safeguarding and protecting all material and equipment stored on the job site. The Contractor shall be responsible for the storage of

materials in a safe and workmanlike manner to prevent injuries, during and after working hours, until project completion.

3.3 PIPE INSTALLATION:

- 3.3.1 Trenching and Backfilling: shall conform to "Technical Specifications for Trenching and Backfilling of Utilities". Trenches shall be free of water during pipe installation. Trench excavation shall require the provisions of vertical curve chords which will not exceed the permissible deflection of the pipe. The bottom of the trenches shall be accurately graded to provide uniform bearing and support for each joint of pipe on undisturbed soil at every point along its entire length. The placement of No. 57 crushed stone shall be placed in the bottom of the trenches when unstable material is encountered. Such unstable material shall be removed to the depth required by the AHJ and replaced with No. 57 stone such that the pipe will be adequately supported throughout its entire length. Excavation below the planned pipe invert elevation shall be refilled with No. 57 crushed stone.
- 3.3.2 PVC and ductile iron pipe shall be installed in accordance with the procedures of AWWA C900 and C600 respectively and with the manufacturer's recommendations. Minimum cover over top of the pipe shall be 36".
- 3.3.3 Pipe fittings shall be installed as shown on the drawings or where necessary so as to not exceed the allowable joint deflection of AWWA C600. All fittings shall be measured and referenced on the Contractor's record drawings.
- 3.3.4 All PVC water main shall be installed with three inch (3") wide metallic detectable tape. The tape shall be clearly marked "Water" and shall be centered over the main, installed twelve inches (12") below finished grade. Any breaks in the tape shall be repaired in accordance with the manufacturer's recommendations.
- 3.3.5 1" Service Tubing: shall be installed with sufficient slack to prevent tension on the line. A maximum of three splices (couplings) per service shall be allowed. Tubing shall have a minimum cover of twenty-four inches (24"). See the standard details. If the service tubing is damaged during construction such that its flow capacity or its life expectancy is adversely affected, the damaged portion shall be replaced. It shall be installed with a minimum of six inches (6") of vertical separation from an existing or proposed storm drain.
- 3.3.6 1 1/2" and 2" services: shall be installed in accordance with the Standard Details. The installation of the Class 200 PVC service pipe shall be in strict conformance with the requirements for mains, except that the service pipe shall have a minimum cover of 24".
- 3.4 CUTTING OF PIPE: Cutting of pipe shall be done in a neat and workmanlike manner without damage to the pipe. Unless otherwise recommended by the manufacturer and authorized by the Owner's Representative, cutting shall be done with a suitable mechanical cutter.

3.5 ADJACENT FACILITIES:

- 3.5.1 Sewer Lines: Where the location of the water pipe is not clearly defined in dimensions on the drawings, the water pipe shall not be laid closer horizontally than 10 feet from a

sewer except where the bottom of the water pipe will be at least 18 inches above the top of the sewer pipe. Where water lines are less than 18 inches above the sewer lines, or cross under sewer lines, the water and sewer pipe for a distance of at least 10 feet each side of the crossing shall be made of ductile iron pressure pipe. The section of water main pipe shall be centered at the crossing

3.5.2 Water lines shall not be laid in the same trench with sewer lines, gas lines, or electric wiring.

3.6 JOINT DEFLECTION: Deflection will be in accordance with the pipe manufacturers recommendations.

3.7 JOINTING

3.7.1 PVC and Ductile Iron Pipe: Push-on type joints shall be installed in accordance with pipe manufacturer's recommendations.

3.7.2 Connections between different types of pipe and accessories shall be made with transition fittings approved by the Owner's representative and the AHJ.

3.8 SERVICE LATERALS: Service Laterals shall conform to the standard details. Meter will be provided by the Owner/Contractor unless otherwise negotiated with the Bertie Co. Regional Water System.

3.9 SETTING OF FIRE HYDRANTS, VALVES, VALVE BOXES AND METER BOXES:

3.9.1 Fire Hydrants shall be located and installed as shown on the drawings and details. Each hydrant shall be connected to the main with a 6-inch branch line having at least three feet of cover. Hydrants shall be set plumb with pumper nozzle facing the roadway and with the center of lowest outlet not less than 18 inches above the finished surrounding grade, and not more than 24 inches above the finished surrounding grade. The hydrant shall be set in a bed of washed rock which shall surround the barrel at least 12 inches in all directions.

3.9.2 Valves and Valve Boxes shall be installed where shown or specified, and shall be set plumb. Valve boxes shall be centered on valve. Where feasible, valves shall be located outside the area of roads and streets. Earth fill shall be carefully tamped around each valve box to a distance of 4 feet on all sides of the box, or to the undisturbed trench face if less than 4 feet. Valve boxes outside of pavement shall have a concrete block 2 feet square by 6 inches thick poured around it, or precast concrete collar set flush with the existing grade.

3.9.3 Hydrants and Valves after delivery shall be drained to prevent freezing and shall have the interiors cleaned of all foreign matter before installation. The hydrant or valve shall be fully opened and fully closed to insure that all parts are in working condition.

3.9.4 Meter boxes and brick for one-inch (1") services shall be provided by the Contractor as shown on the Standard Details. Meter boxes installed for multi-family developments and ganged together shall be marked with the unit number being served. Markings shall be permanently painted on the inside of the frame section and highly visible and shall be in sequential order.

3.10 JOINT RESTRAINT: Plugs, caps tees and bends either vertically or horizontally, on all water lines and fire hydrants shall be provided with joint restraint. Joint restraint will be provided by concrete thrust blocks. In lieu of concrete thrust blocking, piping systems 12 inches and smaller in diameter may be restrained through the use of restrained joint pipe or approved joint restraint devices meeting the material specifications in section 2. The minimum length of piping to be restrained shall be as set forth in the table below.

*Restrained Length (ft.)					
Pipe Size (in.)	4	6	8	10	12
Pipe Cover (ft.)					
3.0	16	24	31	38	46
4.0	15	23	30	37	43
5.0	14	22	29	36	42

* Above values are the lengths of restrained pipe required on each side of fitting. Above values are for 45 horizontal bend. For other horizontal bends multiply above by the following coefficients: 90 - 2.4; 22 1/2 - 0.48; 11 1/4 - 0.24; dead end - 2.4.

The use of joint restraint devices on vertical bends and on piping systems larger than 12 inches in diameter shall not be utilized unless approved by the Bertie Co. Regional Water System.

The use of combined thrust restraint systems employing concrete blocking and joint restraint devices, based on each system being designed to resist a percentage of the resultant thrust force, shall not be permitted. The use of combined systems based on each system being designed to resist all of the resultant thrust force are permitted

3.10.1 Concrete Thrust Blocking: Blocking shall be placed between solid ground and the fitting to be anchored. Unless otherwise indicated or directed the base and thrust bearing sides of thrust blocks shall be poured directly against undisturbed earth. The sides of thrust blocks not subject to thrust may be poured against forms. The area of bearing shall be as shown or as directed. Blocking shall be placed so that the fitting joints will be accessible for repair.

3.11 All boring and jacking installations shall be accomplished with the use of encasement pipe which as a minimum meets the specifications set forth in Section 7.9 of the Manual. The carrier pipe shall be DIP with "push-on" joints in conformance with the requirements of Section 7.2 of this Manual. The ends of the encasement pipe shall be as shown in the Standard Details.

3.12 TESTING OF WATER SYSTEM EXTENSIONS

- 3.12.1 Test Sequence: The following test sequence shall be used unless otherwise approved by the AHJ.
- A. Perform pretest inspection.
 - B. Clean the main.
 - C. Perform the hydrostatic tests.
 - D. Apply the proper dosage of chlorine.
 - E. Allow chlorine solution to remain in the water main a minimum of 24 hours.
 - F. Assist the AHJ in taking bacteriological samples.

3.12.2 Pretest Inspection: Prior to commencement of hydrostatic testing and chlorination, the AHJ shall be contacted to request scheduling of inspection and testing. A AHJ's Representative shall visually inspect the installation prior to testing to insure that all fire hydrants, valves and other appurtenances are properly located, operable, and installed at the proper grade. All defects disclosed by the inspection shall be corrected prior to testing.

3.12.3 Cost of Tests: The cost of testing the mains, including all temporary connections, shall be included in the unit price bid for pipe.

3.13 HYDROSTATIC TESTS

3.13.1 General: Where any section of a water line is provided with concrete thrust blocking for fittings, the hydrostatic tests shall not be made until at least 5 days after installation of the concrete thrust blocking unless otherwise approved. The method proposed for disposal of wastewater from hydrostatic tests and disinfection shall be submitted to the Owner's Representative prior to performing hydrostatic tests.

3.13.2 Tests: Unless otherwise permitted, pressure and leakage testing shall be performed between each main line valve in accordance with AWWA C600. The AHJ will, except when certain circumstances dictate otherwise, permit the lengths of test sections to be a maximum of 1500 feet in subdivisions or other areas where the new main has closely spaced valves. Testing shall be done only in the presence of a AHJ's Representative. Testing shall be performed using a suitable pump and an accurate gauge graduated in 1.0 psi increments. The section of the main to be tested shall be subjected to a test pressure of 150 psi for a period of two (2) hours. The leakage of the test section shall be accurately determined and compared to the schedule shown below. All visible leaks shall be repaired regardless of the amount of leakage.

ALLOWABLE LEAKAGE	
PIPE SIZE	
(inches)	(Gallons per hour per 1000 feet of pipe)
2	0.16
4	0.33
6	0.50
8	0.66
10	0.83
12	0.99
14	1.29
16	1.47
18	1.66
20	1.84
24	2.21
30	2.76
36	3.31

If the leakage is greater than the allowable leakage as given by the above table, the Contractor shall replace any defective materials and perform all necessary work to insure that the installation is acceptable and a retest shall be performed subsequent to any repair work performed. Remedial repair work and retesting shall be repeated until

the leakage occurring during the test period is less than or equal to the allowable leakage.

3.14 CHLORINATION

3.14.1 All water supply mains shall be disinfected by the Contractor. No extra payment will be provided as this work is considered to be an element of other work units. The disinfection process shall be in conformance with the standards of the N.C. Division of Health Services.

3.14.2 Chlorination shall be performed only in the presence of a AHJ's Representative and shall be performed only after the line is complete and has tested satisfactorily for leakage.

3.14.3 Pipe subjected to contaminating materials shall be treated as directed by the AHJ or Engineer; should such treatment fail to cleanse the pipe, replacement shall be required. The Owner shall bear no portion of any cost sustained by Contractor in meeting this specification.

3.14.4 Chlorination of a completed line shall be carried out after completing the pressure test and in the following manner.

3.14.4.1 Chlorination taps will be made within five (5) pipe diameters of the water main control valve at the upstream end of the line and at all extremities of the line.

3.14.4.2 A solution of water containing high test hypochlorite (70%) available chlorine or chlorine gas solution shall be introduced into the line by regulated pumping at the control-valve tap. The solution shall be of such a concentration that the line shall have a uniform concentration of 50 ppm total chlorine immediately after chlorination. The chart below shows the required quantity of 70% HTH compound to be contained in solution in each 1000 foot section of line to produce the desired concentration of 50 ppm. The chlorination solution shall be introduced to the main at a constant rate while regulating the flow of water through the main being chlorinated such that the required concentration of chlorine is achieved throughout

Pipe Size	Pounds High Test Hypochlorite (70%) Per 1000 Feet of Line
6"	1.76
8"	3.12
10"	4.84
12"	7.00
14"	9.52

3.14.4.3 The HTH solution shall be circulated in the main by opening the control valve and systematically manipulating hydrants and taps at the line extremities. The HTH solution must be pumped in at a constant rate for each discharge rate in order that a uniform concentration will be produced in the mains. All valves within the section of main being chlorinated shall be operated once during the contact period.

3.14.4.4 Services shall be chlorinated at the same time and by the same method utilized

for the main.

3.14.4.5 The chlorine solution shall remain in lines for no less than 24 hours, unless otherwise directed by the AHJ.

3.14.4.6 Extreme care shall be taken to prevent contamination of existing water mains during the test period. If, in the opinion of the AHJ, an existing main is contaminated, the section of main subjected to the possible contamination shall be flushed and chlorinated in accordance with the requirements for new mains. The Owner shall bear no portion of any cost sustained by Contractor in meeting this specification.

3.14.4.7 The AHJ will advise the Contractor when a suitable period of time has elapsed for chlorine contact. The main shall be flushed thereafter in the presence and under the direction of the AHJ's Representative. The flushing of the main shall be considered complete when the chlorine concentration with the main is less than or equal to the lesser of the following values:

3.14.4.7.1 One (1) part per million (ppm) free chlorine.

3.14.4.7.2 The free chlorine concentration within the existing main to which the extension has been connected.

3.14.5 The Contractor shall be responsible for insuring that high-strength chlorine solution is contained on-site and not allowed to make its way to any watercourse, stream, creek, lake, or other body of water.

3.15 BACTERIOLOGICAL TESTING

3.15.1 After completion of chlorination and flushing, the Contractor shall assist the AHJ as necessary in obtaining sufficient bacteriological samples for complete testing. Bacteria samples must be tested by a State-approved laboratory. A list of approved laboratories is located on the Public Water Supply website at: http://www.ncwater.org/pws/Compliance/electronic_reporting.html.

3.15.1 The AHJ shall determine the location of samples and the number of samples necessary to provide a test group which is representative of the section of main being tested.

3.15.2 A failure of any sample of a test group shall constitute failure of the entire test group from which the sample was taken. Such failure shall require two (2) successive passing test groups to substantiate that the main has been satisfactorily chlorinated. The Contractor, may at his option, rechlorinate and retest the section of water main upon failure of the test group.

3.15.3 If two (2) successive bacteriological test groups fail, the section of main from which the group is taken shall be rechlorinated and retested until the main is shown to be properly chlorinated in accordance with Paragraph 3.14.

3.16 Cleaning of the Main

3.16.1 General: Mains shall be cleaned only in the presence of a AHJ representative. No valves or hydrants owned by the AHJ shall be operated without the express permission of the AHJ.

- 3.16.2 Cleaning of Water Mains Smaller Than 4" in Diameter: Mains shall be cleaned by flushing. Flushing velocity shall be adequate to remove all debris and other undesirable material and a minimum of 2-1/2 feet per second.
- 3.16.3 Cleaning of water Mains 4" and Larger in Diameter: Mains shall be cleaned only in the presence of a AHJ representative. No valves or hydrants owned by the AHJ shall be operated without the express permission of the AHJ. Cleaning shall be accomplished by passing through the pipe a polyethylene pig ("pig") of the appropriate size and density (as manufactured by Poly-Pig or approved equal). Pig(s) shall be furnished by the Contractor. The procedure shall be as follows:
- a. The Contractor shall prepare the main for the installation and removal of pig(s) as required:
 - i. In general, this will consist of furnishing all equipment, material, and labor to satisfactorily install and remove the pig(s).
 - ii. Prior to beginning construction, Contractor shall submit a "pigging" plan to the Department Engineer for approval. No water main shall be installed prior to approval of the plan.
 - iii. Where expulsion of the pig is required through a dead end main, the Contractor shall prevent the backflow of purged water into the main after expulsion of the pig. For pipe 12" or less in diameter, purged water can be prevented from re-entering into the pipe by the temporary installation of pipe and fittings as required to provide a riser with an above ground discharge. On larger pipe, additional excavation of the trench may serve the same purpose.
 - iv. After expulsion of the pig, completion of flushing, and at the direction of the AHJ, the Contractor shall complete work at openings by plugging, blocking, backfilling and completion of all appurtenant work necessary to secure the system.
 - b. Under supervision of the Inspector, pig(s) shall be propelled via water pressure through the main(s) from point of insertion to point of expulsion. Where mains are in the form of a loop, the Contractor shall "pig" the complete system.
 - c. As an alternative to "pigging", dead end pipes of less than 100 feet in length which are difficult to "pig" may be cleaned by flushing. Flushing shall be accomplished in the same manner as that required for pipes less than 4 inches in diameter.

END OF SECTION

RELATED DOCUMENTS:

Drawings and general provisions of Contract, including General and Supplementary Conditions and Division-1 Specification sections, apply to work of this section.

PART 1: GENERAL

- 1.1 The construction required herein shall include all appurtenant structures. Wye branches and service lines shall be installed as shown or as located by the owner's representative. Excavation and backfilling shall conform to Sections 02200 EARTHWORK, 02210 TRENCHING AND BACKFILLING FOR UTILITIES and DRAWINGS. Work covered by this section will not be accepted until backfilling and testing connected with work has been completed satisfactorily.
- 1.2 Current specifications of the American Society for Testing Materials (ASTM) and the American National Standards Institute (ANSI) shall apply in all cases where material is covered by an item in these specifications, and all material used under this contract shall conform fully to these current specifications or be removed from the job at the direction of the Owner. Failure of the Owner to condemn material on preliminary inspection shall not be grounds for acceptance if future defects are found.
- 1.3 Contractor shall be responsible for verifying all elevations, dimensions, locations and sizes of existing facilities in the field prior to construction or ordering materials.
- 1.4 The Contractor shall construct and maintain all detours, crossings and temporary approaches that may be required during construction. Maintenance shall be in accordance with the applicable features of Section 150 of the N.C. Standard Specifications for Roads and Structures.
- 1.5 Property Protection:
 - 1.5.1 Trees, fences, poles and all other property shall be protected unless their removal is authorized, and any property not authorized for removal, but damaged by the Contractor shall be restored by the Contractor to the owner's satisfaction.
 - 1.5.2 Signs, mailboxes and other items which must be removed to facilitate construction shall be replaced in a condition equal or better than condition prior to removal. Replacement shall occur immediately following backfill of the trench at the location of each item removed.
 - 1.5.3 All existing drainage shall be maintained at all times on the Project. Any drainage swales, ditches, culverts, etc. blocked by construction activities shall be reopened at the end of the day before leaving the job site.
- 1.6 Encroachment Contracts and Permits:
 - 1.6.1 Prior to actual construction, the Owner shall acquire the necessary encroachments from NCDOT for installations. When working inside the rights-of-way of State system roads for highways, the Contractor shall acquire the necessary permits for his work.
 - 1.6.2 The Contractor shall be responsible for securing all other local and state permits required for the utility construction.
 - 1.6.3 Open cut shall be used for excavation of all sewer mains unless written permission of the Owner is given, or as specified by the encroachment agreement with the N.C. Department of Transportation.

PART 2: MATERIALS

- 2.1 DUCTILE IRON PIPE: All ductile iron pipe shall be manufactured in compliance with ANSI Standard A21.51. The interior of the pipe shall be cement-mortar lined in accordance with ANSI A21.4. The exterior of the pipe shall have a one (1) ml bituminous coating in accordance with ANSI 21.51. The thickness class for ductile iron pipe shall be Class 50 unless required otherwise by the Commission. Pipe shall be in nominal 18-20 foot laying lengths. The pipe joints for ductile iron pipe shall be lipush-on" manufactured in accordance with ANSI 21.11. Polyethylene encasement shall be applied to all underground ductile iron pipe installations. Materials and installation procedures shall be in accordance with ANSI/AWWA C105/A21.5.88.
- 2.2 SEWER SERVICE PIPE: Sewer service pipe shall be schedule 40 PVC - Drain, waste and vent (DWV) pipe in accordance with ASTM D2665 and ASTM D1785.
- 2.3 Polyvinyl Chloride (PVC) Pipe 8"-15". PVC pipe shall conform to the requirements of ASTM D3034 (SDR35). Joints and fabricated fittings shall be elastomeric (gasket) joints and shall be assembled in accordance with the pipe manufacturer's recommendations and Specification D3212. Gaskets shall meet the requirements of ASTM F477. Minimum cell class shall be 12454B. PVC pipe shall be supplied in 13.0 foot lengths.
- 2.4 PVC Composite Pipe. PVC composite pipe shall conform to the requirements of ASTM D2680, Standard Specification for Poly (Vinyl Chloride). Joints and fabricated fittings shall be elastomeric (gasket), joints and shall be assembled in accordance with the manufacturer's recommendations. Minimum cell class shall be 12454B. The pipe shall be similar in all respects to Armco Truss Pipe as manufactured by Contech Construction Products, Inc. PVC composite pipe shall be supplied in 12.5 foot lengths.
- 2.5 Service Fittings
- 2.6 Services from ductile iron pipe less than 18" in diameter shall be provided by means of ductile iron wyes meeting the requirements for water main fittings. Services from ductile iron pipe 18" in diameter and larger shall be provided by wyes
- 2.6.1 Service fittings for use on PVC composite pipe shall be PVC standard gasketed wyes manufactured or approved by the pipe manufacturer and shall conform to the requirements of ASTM D2680.
- 2.6.2 Service fittings for use on PVC (SDR 35) pipe shall be a standard gasketed wyes manufactured or approved by the pipe manufacturer and shall conform to the requirements of ASTM D3034.
- 2.7 PRECAST REINFORCED CONCRETE MANHOLES. Manholes shall be precast and have monolithic bottom sections. Manholes with a depth greater than 6 feet shall have eccentric cones, manholes with a depth of 6 feet or less shall have either an eccentric or concentric cone. Manholes shall conform to latest ASTM C-478 specifications. Top slabs when used, shall be satisfactory for H-20 highway loading. Joints shall be watertight and conform to either the latest ASTM C-443 specifications for "O" ring joints Sewer 3 or the latest ASTM C-478 specifications for section joints designed for cold applied sealing compound. Sealing compound shall be CPS-210 as manufactured by Concrete Products Supply Company, or CS 102 as manufactured by Concrete Sealants. Points of exit and entry for all pipe including services shall be provided with flexible manhole sleeves and all stainless steel take up clamps in accordance with ASTM C-923. Points of entry for mains or services which are added after fabrication of the manhole shall be provided by coring and installation flexible sleeve. All pipes shall extend through the manhole a

minimum of 2 inches. Manholes with preformed invert channels and benches may be utilized. Points of pipe exit and entry shall conform with the above paragraph. Manholes that are field tested shall be done in accordance with the Standard Details. All Manholes shall be set on crushed aggregate of at least 1 ft. depth. All pinholes shall be filled with non-shrink grout. Tie into existing Manhole must be made by machine coring.

- 2.7.1 MANHOLE FRAMES AND COVERS. Manhole rings and covers shall be manufactured in the USA of Class 30, gray cast iron conforming to the requirements of ASTM-A48 (latest revision thereof). The manufacturer's name and part number shall be cast into each component and the words "Sanitary Sewer" shall be cast into the cover. Pick holes shall be the non-penetrating type. Bearing surfaces of both ring and cover shall be machined to insure proper fit and to prevent rattling. Non watertight units shall be either MH-RCR-2001 by Dewey Bothers, V-1384 by Vulcan Foundry, or USF 669 ring and KL cover by US Foundry. Watertight units shall be either MH-RCR-3000W by Dewey Brothers or USF 579 ring and DC-SSG cover by US Foundry. When required to be lockable, covers shall contain a locking device comprised of a stainless steel pentagon head bolt locking device which functions in the manner of a quarter turn fastener. All castings shall meet industry standards in regard to appearance and tolerances for dimensions and weight. Castings do not have to be painted.
- 2.7.2 MANHOLE STEPS. Manhole steps shall be constructed of 1/2" grade 60 steel bars with a plastic coating and shall meet federal specification RR- F-621C. Maximum vertical step spacing shall be sixteen inches (16") on center.
- 2.8 MASONRY: Masonry construction shall conform to N.C. Department of Transportation Standard Specifications and latest revision Section 940. Mortar joints shall be thoroughly filled and the thickness shall not be more than three-eighths (3/8) of an inch.
- 2.9 REINFORCED CONCRETE. Reinforced concrete used in construction of piers, manholes and other structures shall conform to the applicable sections of the N.C. Department of Transportation Standard Specifications, revised January 1, 1990. Concrete used in the structures shall be Class A, 3, 000-pound test in accordance with Section 900. Reinforcing steel shall conform to ASTM A-615, Grade 60 unless otherwise specified and shall conform to N.C. Department of Transportation Standard Specifications Section 425.
- 2.10 STONE BEDDING. Stone used for bedding of sewer mains, manholes and concrete piers shall be granite crushed stone (NCDOT Size No. 57) as per Section 905 of N.C. Department of Transportation Standard Specifications as revised January 1, 1990 and in accordance with Section 02210, TRENCHING AND BACKFILLING FOR UTILITIES.
- 2.11 TRANSITION COUPLINGS. The preferred transition connection between different sewer line materials shall be a standard manhole installation. Pipe material changes between manholes may be permitted provided that there is not a substantial difference in inside diameters, a smooth uniform flow line is maintained, and a watertight rubber sleeve, mechanical coupler conforming to ASTM C-425 is used to make the transition. All metal hardware shall be stainless steel. Transition sleeves shall be manufactured by Fernco or Indiana Steel.
- 2.12 CLEAN-OUTS: Shall be constructed of pipe and fittings which also meet the ASTM requirement for Schedule 40 PVC-DWV pipe. Cleanout caps shall be Charlotte 110 or Jones BP134CSK flush cap except cleanouts in paved locations shall be constructed of cast iron and have a brass plug. Cleanouts located in traffic or paved areas may be constructed of PVC except for the upper two feet of the riser which shall be constructed of cast iron soil pipe and have a brass cap.
- 2.13.1 STEEL ENCASEMENT PIPE: Steel encasement pipe shall be spiral welded or smooth wall seamless, consisting of grade "B" steel with a minimum yield strength of 35,000 psi and

manufactured in accordance with ASTM A139 and A283. The pipe thickness shall be in accordance with the requirements of the right-of-way owner, but in no case less than that shown in the following table. The ends shall be beveled and prepared for field welding at the circumferential joints.

- 2.13.2 METALLIC LOCATOR TAPE: Provide continuous metallic locator tape above all pipe installation as per Drawings.

MINIMUM WALL THICKNESS FOR STEEL ENCASEMENT PIPE

<u>NOMINAL DIAMETER IN INCHES</u>	<u>MINIMUM THICKNESS IN INCHES:</u>
4 - 12-3/4	0.188
14	0.219
16- 18	0.250
20	0.281
22	0.312
24	0.344
26	0.375
28- 30	0.406
32	0.438
34- 36	0.469
38- 42	0.500

The encasement pipe shall be uncoated inside and out.

Encasement pipe and joints shall be of leakproof construction, capable of withstanding design loading. The inside diameter of the encasement pipe shall be at least 2 inches greater than the largest outside diameter of the carrier pipe, joints or couplings, for carrier pipe less than 6 inches in diameter; and at least 4 inches greater for carrier pipe 6 inches and larger in diameter. It shall, in all cases, be great enough to allow the carrier pipe to be removed subsequently without disturbing the casing pipe or roadbed.

- 2.14 FORCE MAIN PIPE AND OF APPURTENANCES: Steel

- 2.14.1 Sewer force main pipe shall be a minimum of Class 200 PVC pipe or Class 50 ductile iron pipe.
- 2.14.2 PVC shall be Class 200 C-900 conforming to ASTM D1784 and ASTM D2241 (latest revisions). Fittings for PVC force main shall be ductile iron meetings the requirements of ANSI A21.10 and shall be designed for a minimum working pressure of 150 psi plus 100 psi surge pressure. The interior of all fittings shall be cement-mortar lined in accordance with ANSI 21.4 and the exterior of the fittings shall be bituminous coated in accordance with ANSI 21.51.
- 2.14.3 Ductile iron force main and fittings shall meet the requirements for ductile iron water main set forth in Section 02713.
- 2.14.4 Directional Bored Force Mains:
- 2.14.5 High Density Polyethylene (HDPE) Force Main: shall conform to AWWA C9906 and shall have a wall thickness and pressure rating equivalent to C-900 Class 200 PVC pipe. Pipe shall be DISCOPIPE or approved equal.

PART 3: CONSTRUCTION METHODS

3.1 GENERAL: Pipe shall be installed in accordance with specifications and recommendations by the Manufacturer. Before any installation is begun, the Contractor shall notify NC One Call at least 48 hours prior to commencing construction in order that existing utilities in the area may be flagged or staked. The Contractor shall be responsible for damage to any existing overhead and underground utility system.

3.2 HANDLING AND STORING MATERIALS:

3.2.1 The Contractor shall be responsible for the shipping and storing of all sanitary sewer materials. Any material which is damaged or defective shall be replaced by the Contractor at his own expense.

3.2.2 The loading and unloading of all pipe, manholes and other accessories shall be in accordance with the manufacturer's recommended practices and shall at all times be performed with care to avoid any damage to the material.

The Contractor shall locate and provide the necessary storage areas for materials and equipment. If private property is being used for storage areas, Contractor must have the written consent from the property owner.

3.2.3 All materials once on the job site shall be stored in accordance with the manufacturer's recommendations.

3.2.4 The Contractor shall be responsible for safeguarding and protecting all material and equipment stored on the job site. The Contractor shall be responsible for the storage of materials in a safe and workmanlike manner to prevent injuries, during and after working hours, until project completion.

3.3 PIPE INSTALLATION:

3.3.1 PIPE INSTALLATION: Flexible thermoplastic sewer pipe shall be installed in accordance with ASTM D2321- 83a, except as modified by these specifications and the specific recommendations of the pipe manufacturer.

3.3.2 CUTTING OF PIPE: Pipe cutting, where permitted, shall be done in accordance with the written recommendations of the pipe manufacturer. Only factory cut ends shall be used for solvent weld joints.

3.3.3 TRENCHING: Trenches shall be excavated in straight lines and uniformly sloped between manholes or junction structures. The trench shall be excavated a minimum of six inches (6") below the pipe bottom in order to receive the required 6" foundation bedding of No. 57 crushed stone. Bed and haunch pipe in accordance with requirements set forth in Section 02210, TRENCHING AND BACKFILLING FOR UTILITIES, and Drawings.

3.3.4 FOUNDATION STONE: The Contract Documents shall provide for the construction of a Foundation bedding of No. 57 crushed stone in the bottom of trenches. Reference Drawings and Section 02210 TRENCHING AND BACKFILLING FOR UTILITIES.

When unstable trench bottom material is encountered, such unstable material shall be removed to the depth required by the Owner's testing firm representative and replaced with No.57 stone such that the pipe will be adequately supported throughout the entire length. Excavation below the planned pipe invert elevation as shown on the Approved Plans shall be refilled with No. 57 crushed stone.

3.3.5 **DIRECTIONAL BORING:** Direction boring / drilling installation shall be accomplished where required on the Plans or in the Special Provisions to minimize disturbance of existing surface improvements. The Contractor shall submit boring / drilling pit locations to the Owner before beginning construction. The drilling equipment shall be capable of installing continuous runs of pipe without intermediate pits, a minimum distance of 200 feet. The guidance system shall be capable of installing pipe within 1-1/2 inch of the plan vertical dimensions and 2-inches of the plan horizontal dimensions. The Contractor shall be required to remove and reinstall pipes, which vary in depth and alignment from these tolerances. Pull back forces shall not exceed the allowable pulling forces for the pipe being installed. Drilling fluid shall be a mixture of water and bentonite clay. Disposal of excess fluid and spoils shall be the responsibility of the Contractor.

3.3.6 **BORING AND JACKING:** All boring and jacking installation shall be accomplished with the use of encasement pipe which at a minimum meets these specifications. Install steel pipe encasements by boring and or jacking or by pushing the casing pipe through a bored hole. Ensure that the encasement is installed true to line and grade.

The boring machine shall be designed to bore and push or jack the casing on a controlled grade and line in a continuous operation. The boring auger shall not be of a greater diameter than the outside diameter of the casing.

Bore progressively ahead of the advancing pipe while spoil is removed by the auger back through the pipe.

Butt-weld each new section of the encasement pipe to the section previously jacked into place as the boring operation continues.

Protect ends of encasement in an acceptable manner to prevent the entrance of foreign materials or debris.

If voids are encountered or occur outside the encasement pipe, grout holes shall be installed in the top section of the encasement pipe and the voids filled with 1:3 portland cement grout at sufficient pressure to prevent settlement in the roadway.

In the event an obstruction is encountered during the boring and jacking operation, notify the ENGINEER of the obstruction and obtain written authorization from the ENGINEER prior to proceeding with the premature termination of that boring.

When premature termination of a boring is authorized, the auger is to be withdrawn and the excess pipe is to be cut off, capped, and filled with 1:3 portland cement grout at sufficient pressure to fill all voids before moving to another boring site.

Ensure that encasement pipe is installed at the alignment and grade shown on the drawings. Report, in writing, any deviation in the alignment and grade from that shown on the drawings.

Joint carrier pipe in accordance with manufacturer's specifications.

Carefully secure pipe supports to each joint of carrier pipe. Supports shall be placed at each end of the casing, at each pipe bell for DIP, and at intervals not greater than 4 feet for PVC or ABS pipe. For gravity sewer the supports shall be constructed to maintain the proper slope of the line even when the casing alignment deviates from the slope shown on the drawings.

Carefully push carrier pipe through encasement ensuring that the assembly is not damaged.

Ensure that the carrier pipe is installed at the alignment and grade shown on the drawings.

3.4 ADJACENT FACILITIES

3.4.1 WATER LINES: Unless otherwise shown on the drawings, the sewer shall not be located closer than 10 feet to a water line, except where the bottom of the water line is greater than 18 inches above the top of the sewer pipe. Where the vertical separation is less than 18 inches, or where the sewer line crosses above the water line, both the water line and sewer line shall be constructed of ductile iron pipe, for a distance of 10' in each direction from the crossing. The section of water line pipe shall be centered at the crossing.

3.5: BACKFILL: Backfill in accordance with Section 02210 TRENCHING AND BACKFILLING FOR UTILITIES. Provide continuous metallic locator tape above all pipe installations as per Drawings.

3.6 SERVICE CONNECTION: Service Connections shall be installed at locations shown on the drawings, or as designated by the owner's representative and be at right angles to the gravity sewer.

3.6.1 Service Connections shall consist of a wye branch, fittings, clean-out, and 411 pipe, unless otherwise shown or directed.

3.6.2 Service Laterals shall include a clean-out located at the right-of-way limit five feet (5') down stream of the water meter, unless otherwise noted on the plans.

3.7 MANHOLES:

3.7.1 GENERAL: Manholes shall be constructed of precast concrete rings with cast iron frames and covers, and in accordance with the drawings. The manhole inverts shall be constructed with a width and height equal to that of the effluent pipe and shall be so brushed and troweled that a minimum energy loss occurs in the manhole due to invert roughness. Changes in direction of flow shall be made with a smooth curve of as large a radius as the size of the manhole will permit. Changes in size and grade of the channels shall be made gradually and evenly. Manholes shall be provided with steps of acceptable design not less than 10 inches in width, built into and securely anchored in the walls. Steps shall be spaced uniformly approximately 16 inches.

3.7.2 JOINTING AND PLASTERING: Installation of water tight joints between precast rings shall conform to either ASTM C443 standard for "o" ring joints, or the ASTM C478 standard for section joints designed for cold applied sealing compound in accordance with recommendations of the manufacturer. The sealing compound shall be CPS-210 as manufactured by Concrete Products Supply Company or CS102 as manufactured by Concrete Sealants.

3.8 TESTING:

3.8.1 GENERAL: The Contractor shall be responsible for providing all pumps, gages, instruments, test equipment and personnel required for testing operations. The Contractor shall also be responsible for cleaning and pre-testing the sewer system extension prior to notifying the Engineer and arranging for final inspections and tests.

All defects in the pipeline and appurtenances shall be remedied by the Contractor at no additional cost to the Owner.

The Contractor shall be required by the Contract Documents to clean and pretest the sewer system extension prior to notifying the Engineer and arranging for final inspections and test.

The Engineer shall be contacted prior to testing to schedule the test time such that the Engineer representative may be present. The Owners representative shall be present during all testing.

3.8.2 TESTING SEQUENCE: The following test sequence shall be used unless otherwise approved by the Owner:

1. Perform a visual inspection
2. Correct defects revealed by visual inspection
3. Perform leakage testing
4. Make any necessary repairs
5. Make the necessary retests

3.8.3 VISUAL INSPECTION: The sewer shall be inspected from every manhole by use of mirrors, television cameras or other devices. The lines shall appear circular in cross section with no noticeable deflection. Lines which do not meet specified tolerances or which have structural defects shall be replaced to meet the requirements of the Engineer prior to leakage testing.

3.8.4 LEAKAGE TESTING: All segments of completed line, including services, shall be tested for leakage by low pressure air test. Testing shall be performed in the presence of the Engineer or his representative.

A. The Contractor shall remedy all visible leaks in pipes, manholes, and appurtenances.

B. Low Pressure Air Test: Tests for leakage for individual line segments shall be made by low pressure air test. Test shall conform to the requirements as follows:

1. All air testing and retesting results shall be recorded on copies of the Air Data Sheets enclosed herein and submitted to the Engineer for approval.
2. Air leakage testing of installed system shall be performed with continuous monitoring gauge no less than 4 inches in diameter with minimum divisions of 0.10 psi and an accuracy of plus or minus 0.04psi. All air used shall pass through a single, above ground control panel visible to the Project Representative during the testing.
3. Determine the ground water elevation and determine the average ground water head above the section of line being tested. Adjust the following test pressures by adding 0.43 psig per foot of ground water head above the pipe invert.
4. Pressurize the system to 4.0 psig (greater than average ground water pressure). Throttle the air supply to maintain that constant pressure for at least 2 minutes. The air pressure supply shall then be disconnected from the system or shut off. Do not exceed 9.0 psig in the system.

5. As a safety precaution, no one shall be allowed in a manhole after the air pressure is increased in the sewer line. If the Resident Inspector suspects that the test plug may be leaking, the pressure first shall be relieved before any adjustments are made to eliminate air leakage at the plug. The Contractor may precoat the plug with a soap solution to check the plugs for leakage.
6. Observe the continuous monitoring gauge while decreasing the pressure to no less than 3.5 psig (greater than ground water pressure). At a reading of 3.5 psig (adjusted) or any convenient observed pressure reading between 3.5 and 4.0 psig (adjusted), timing shall commence with a stop watch or other timing device that is at least 99.8 percent accurate.

Measure the time interval for pressure to drop 1.0 psig.

7. If the time, shown in the following Table I for the designated line size and length, elapses before the air pressure drops 1.0 psig; the section undergoing test may be discontinued once the prescribed time has elapsed even though the 1.0 psig drop has not occurred. Record all readings.
8. If the pressure drops 1.0 psig before the appropriate time shown in the Table I has elapsed, the air loss rate shall be considered excessive and the section of pipe has failed the test. Record all readings.
9. If lateral sewers are included in the test section, their lengths may be ignored for computing and required test times. The test will be slightly more severe. In the event a test section having a total surface area less than 625 square feet, fails to pass the air test when lateral sewers have been ignored, the test time shall be recomputed to include all lateral sewers using the following formula:

Where T = Shortest allowable time, in seconds for the air pressure to drop 1.0 psig: $K = 0.000419 (D1L1 + D2L2 + \dots + DnLn)$, but not less than 2.0";
 $Q = 0.0015$ cu.ft./min./sq.ft. of internal surface) D1, D2,..., Dn = Nominal diameters of the different size being tested. L1, L2,..., Ln = Respective lengths of the different size pipes being tested.

If the recomputed test time is short enough to allow the section to pass, the section undergoing test shall have passed.

10. If the sections fail the air test, the Contractor shall determine at his own expense, the source, or sources of leakage, and shall repair or replace all defective materials and workmanship.
 11. No sealant shall be used in the newly installed sewers to correct the leaks without prior approval of the Engineer.
 12. The extent of the type of repair which may be allowed shall be subject to the approval of the Engineer.
 13. The repaired pipe installation shall be retested and required to meet the requirements of this test.
- C. Infiltration or Exfiltration Test: for leakage shall not be accepted without prior written approval of the Engineer. For these methods to be considered, the Contractor shall state in writing reasons for this consideration.

Should water exfiltration or infiltration testing be allowed, the maximum leakage rate shall be 50 gallons per inch of pipe diameter per mile of pipe per 234 hours; test ground water depths must be 4 feet minimum; all liquid measurements must be made with a Pomon-O-Weir or equal device. V-notch where measurements shall not be allowed.

- 3.8.5 DEFLECTION TESTING FOR PVC (SDR 35): If PVC (SDR 35) sewer pipe is utilized, deflection testing shall be required with a rigid device (mandrel) sized to pass 5% or less deflection (or deformation) of the pipe.

Deflection test 100% of the total footage of solid wall PVC pipe. Deflection test is not required on PVC Truss Pipe or Ductile Iron Pipe.

The mandrel device shall be cylindrical in shape and constructed with nine or ten evenly spaced arms or prongs. Mandrels with less than nine arms will not be approved for use. The dimensions of the mandrel shall be as listed in the table below:

Note: The diameter of the mandrel shall carry a tolerance of plus or minus 0.01 inch.

Nominal Diameter	Contact Length	Mandrel Diameter ASTM 3034 SDR 35	Mandrel Diameter ASTM D2680
8"	8"	7.28"	7.36"
10"	10"	9.08"	9.26"
12"	12"	10.79"	11.16"
15"	12"	13.20"	14.01"

Allowance for piping wall thickness tolerances or ovality (from heat, shipping, poor production, etc.) shall be deducted from the "D" dimension but shall not be counted in as a part of the 5% or lesser deflection allowance.

The mandrel shall be hand pulled by the Contractor through all sewer lines in the presence of the Engineer or his Representative. Any sections of the sewer not passing the mandrel shall be uncovered and the Contractor shall reround or replace the sewer to the satisfaction of the Engineer. These repaired sections shall be retested.

The inspection shall be conducted no earlier than 30 days after reaching final trench backfill grade, provided in the opinion of the Engineer that sufficient water densification or rainfall has occurred to thoroughly settle the soil throughout the entire trench depth. If this cannot be achieved in the time after installation prior to the project completion date, then the mandrel size shall be increased to measure 1/3 less of a deflection allowance.

Contact length shall be measured between points of contact of the mandrel arm. This length shall not be less than that shown in the table above.

The mandrel may not be used until approved by the Engineer. Proving rings provided by contractor shall be used to assist in this. Drawings of the mandrel with complete dimensions shall be furnished by the Contractor to the Engineer for each diameter and specification of pipe.

The mandrel device shall be as manufactured by H and H Fabricating of Fairfield, Ohio or Wortco, Inc. of Franklin Ohio; and shall be approved by the Engineer."

- 3.8.6 **MANHOLE TESTING:** Each manhole shall be tested for leakage immediately after assembly and prior to backfilling. The test method shall be the vacuum test.
- A. All lift holes shall be plugged with non-shrink grout.
 - B. All pipes entering the manhole shall be plugged.
 - C. The test head shall be placed at the inside of the top of the cone section and the seal inflated in accordance with the manufacturer's recommendation.
 - D. A vacuum of ten inches (10") of mercury shall be drawn and the vacuum shut off. With the valves closed, the time shall be measured for the vacuum to drop to nine inches (9") . The manhole shall pass if the time is greater than sixty (60) seconds for forty-eight inches (48") diameter, seventy-five (75) seconds for sixty inch (60"), and ninety (90) seconds for seventy-two inch (72") diameter manholes.
 - E. If the manhole fails the initial test, necessary repairs shall be made with a non-shrink grout while the vacuum is still being drawn. Retesting shall proceed until a satisfactory test is obtained.
- 3.8.7 **FORCE MAIN TESTING:** Shall be in accordance with paragraph 3.12 of Section 02713 Water Mains. It is the Contractor's responsibility to install taps for pressure testing in adequate locations to identify any leaks and pass hydrostatic test.

END OF SECTION

RELATED DOCUMENTS

The general provisions of the Contract, including General and Supplementary Conditions and General Requirements, apply to the work specified in this section.

PART 1 - GENERAL

RELATED WORK SPECIFIED ELSEWHERE:

Section 02200 Earthwork

DESCRIPTION OF WORK:

The extent of storm sewer collection system work and materials required are shown on drawings.

Storm Sewer collection system may include, in complete assemblies, but is not limited to, all of the following:

- Dual Wall HDPE Pipe
- Storm sewer pipe, RCP and PVC.
- PVC Plastic Structures for Underground Drainage Piping System.
- Trench Drains
- Rip Rap.
- Catch basins / Manholes

QUALITY ASSURANCE:

CODE AND STANDARDS: Comply with applicable requirements of NCDOT.

SUBMITTALS:

Shop Drawings, Storm Sewer System: Submit shop drawings for the system, including details of underground structures, metal accessories, fittings, and connections, and any variations from those details shown on the drawings.

MATERIAL CERTIFICATES: Provide material certificates signed by the material manufacturer and Contractor for all pipe manhole, catch basins, frames and grates indicating each complies with specifications.

PART 2 - PRODUCTS

CONDUIT MATERIALS:

Dual Wall HDPE Pipe: Corrugated, smooth interior, high-density polyethylene (HDPE) pipe, with ASTM D3212 water-tight reinforced integral bell & gasketed spigot jointing. Pipe and fittings shall comply with AASHTO M252 Type S, AASHTO M294 Type S, ASTM F2306.

Polyvinyl Chloride (PVC) Pipe: PVC pipe shall conform to the requirements of ASTM D3034 (SDR35). Joints and fabricated fittings shall be glued hub joints and shall be assembled in accordance with the pipe manufacturer's recommendations and Specification D3212. Minimum cell class shall be 12454B. PVC pipe shall be supplied in 13.0 foot lengths.

Reinforced Concreted Pipe (RCP):

RCP shall be of tongue and groove construction in accordance with ASTM C-76, Class III. All pipe shall be stamped by supplier - "R. C.". Joint material shall be ConSeal CS-102 Butyl Rubber Sealant gasket, or ConSeal CS-202 Butyl Rubber Sealant gasket conforming to ASTM C 990, and Federal Specification SS-S-210.

TRENCH DRAINS:

Provide vehicle traffic grade Trench Drains where indicated. Provide polymer concrete products equal to ACO Drain K100S complete with heavy duty longitudinal stainless steel gratings locked down with quick locking bolt and bar type lockings as manufactured by ACO Polymer Products.

Provide general purpose grade Trench Drains designed for use in concrete slab applications where indicated. Provide fiberglass channel products equal to ACO Drain FG100 complete with Load Class B, ADA rated, perforated longitudinal stainless steel gratings, locked down with quick locking bolt and bar type lockings as manufactured by ACO Polymer Products.

PVC DRAIN BASINS and INLINE DRAINS:

Provide vehicle traffic grade Drain Basins and Inline Drains where indicated shall be PVC with heavy duty ductile iron grates. Products equal to Nyloplast by Advanced Drainage Systems.

CONCRETE MANHOLES:

General: Manholes and Catchbasins shall be precast concrete where indicated. Manholes not of a conventional size may be of concrete block or brick.

Precast Concrete Manholes: Shall comply with ASTM C-478, sized as indicated, with an eccentric cone, precast top, precast bottom and O-Ring joint conforming to ASTM C 493, or RAM-NEK Preformed Plastic Gasket.

Interior diameter of precast manholes shall be based upon pipe size as follows unless otherwise indicated:

<u>Pipe Size</u>	<u>Interior Diameter</u>
Less than 24"	4'
24" - 30"	5'
Larger than 30"	6'

FLOATING AERATOR FOUNTAIN

Surface Floating Aerator Fountain: Where indicated provide UL certified/listed 2HP Model 200 Gemini Aerating Fountain, as manufactured by Otterbine Barebo, Inc., floating, surface spray aerator with a trumpet shaped spray pattern. Fountain shall introduce oxygen into the water column for water quality management, controlling algae, aquatic weeds, and foul odors. Pumping rate and spray pattern dimensions shall be as recommended by manufacturer.

Provide complete assembly, including pumping capacities as required, full flotation float, impeller, motor, motor housing, electrical connectors, underwater power cable, cable quick disconnects, and power control center. All fasteners shall be stainless steel. Provide manufacturer's five-year warranty.

Provide a controls panel in a NEMA rated waterproof cabinet, complete assembly.

Installation shall be completed in accordance with manufacturer's specifications and manufacturer's written installation instructions. All electrical installation shall comply with local Building Codes and the current NEC.

MASONRY MATERIALS:

Concrete Masonry Units (Manhole Block): ASTM C 139.

Manhole Drop Inlet and Catch Basin Brick: ASTM C 32, Grade MS.

Concrete Brick: ASTM C 55, Grade NI.

Masonry Mortar: ASTM C 270, Type M, approximately 1:1 / 4:2 Portland Cement, lime, sand.

Concrete Block: ASTM C 90, Grade NI.

For minor amounts of mortar, packaged materials complying with ASTM C 387, Type M, will be acceptable.

Plasticizing Agent: Omicron or equal. Use in accordance with manufacturer's instructions.

ACCESSORIES:

General: All metal accessories for manholes, catch basins and drop inlets shall be gray cast iron, ASTM A 48, Class 30B. Frames, grates and covers shall be factory coated with an asphalt base paint. Install metal accessories as shown on the drawings.

Rip Rap: Rip rap shall be accomplished in accordance with Section 868 of the N. C. State Highway Specifications for Roads and Structures. Rip rap shall be located and be of the class shown on plans.

Filter Cloth: Filter cloth shall be composed of strong rot proof synthetic fibers formed into a fabric shall be free of any treatment or coating which might significantly alter its physical properties after installation. The filter cloth shall have a puncture strength to withstand a minimum force of 100 lbs., in accordance with ASTM D 751. Filter cloth as manufactured by Monsanto, Carthage Mills, Inc., or approved equal will be acceptable.

Downspout Transition Boots: Downspout transition boot fitting for each downspout shall be a PVC Sewer Solvent Weld Downspout Adaptor, sized for 4"x4" downspout transition to the underground leader pipe size indicated. Provide an SDR 35 fitting, meeting ASTM D-2729, and ASTM D-3034 requirements, utilizing solvent welded connection to SDR 35 PVC pipe leaders. As manufactured or distributed by Ferguson, Genova, NDS or equivalent.

Flexible Downspout Transition Boots: Downspout pipe or roof drain leader pipe transition boot fittings for each existing downspout shall be a flexible elastomeric PVC Sewer Downspout Adaptor, sized for existing downspout pipe transition to the new underground leader pipe size indicated. Provide a flexible PVC fitting, meeting ASTM D-2729, and ASTM D-3034 requirements, utilizing 300 series stainless steel pipe clamp connections to new underground pipe leaders. As manufactured or distributed by Ferguson, Genova, NDS or equivalent.

Field examine existing downspout or roof drain leader pipes to determine exact pipe and fitting sizes, and provide the couplings, reducers, connectors, or elbows to suit the condition required for complete transitions.

PART 3 - EXECUTION

INSPECTION:

Contractor must examine the areas and conditions under which storm sewer system work is to be installed. Do not proceed with the work until unsatisfactory conditions have been corrected in a manner acceptable to the Engineer.

INSTALLATION OF CONDUIT (PIPE):

General:

Perform excavation, trenching, bedding, haunching and backfilling as specified in appropriate Division 2 Sections. Conduct backfill operations of open-cut trenches closely following laying, jointing and bedding of pipe, and after initial inspection and testing are completed.

Pipe bedding, haunching and backfilling layers shall be in accordance with requirements set forth on Drawings, and in Section 02210, TRENCHING AND BACKFILLING FOR UTILITIES.

Inspect conduit before installation to detect any apparent defects. Mark defective materials with white paint and promptly remove from the site.

Particular care shall be taken to prevent damage to pipe and fitting linings and coatings. Pipe shall be protected during handling against impact shocks and free fall.

Lay conduit beginning at the low point of a system, true to the grades and alignment indicated with unbroken continuity of invert. The line and invert grade of each pipe shall be checked from top line carried on batter boards not over 24' apart or by a laser and target.

Cross above or below other pipe a minimum of 6" unless otherwise directed by the Engineer.

Place bell ends of conduit or the groove end of concrete facing upstream.

Bell holes shall be excavated for each joint to assure bedding supports the barrel of the pipe and to facilitate making a perfect joint. Preparatory to making pipe joints, all surfaces of the portion of the pipe to be jointed or of the factory-made jointing materials shall be clean and dry.

Install gaskets in accordance with manufacturer's recommendations for the use of lubricants, cements, and other special installation requirements.

The Contract Documents shall provide for the construction of a 6" Foundation Bedding of No. 57 crushed stone pipe bedding in the bottom of trenches. Reference Drawings and Section 02210 TRENCHING AND BACKFILLING FOR UTILITIES.

When unstable trench bottom material is encountered, such unstable material shall be removed to the depth required by the Owner's testing firm representative and replaced with No.57 stone such that the pipe will be adequately supported throughout the entire length. Excavation below the planned pipe invert elevation as shown on the Approved Plans shall be refilled with No. 57 crushed stone.

Reinforced Concrete Pipe (RCP): Install in accordance with applicable provisions of the American Concrete Pipe Association "Concrete Pipe Field Manual", unless otherwise indicated.

PVC PIPE INSTALLATION:

Flexible thermoplastic sewer pipe shall be installed in accordance with ASTM D2321- 83a, except as modified by these specifications and the specific recommendations of the pipe manufacturer.

Pipe cutting, where permitted, shall be done in accordance with the written recommendations of the pipe manufacturer. Only factory cut ends shall be used for solvent weld joints.

Trenches shall be excavated in straight lines and uniformly sloped between manholes or junction structures. The trench shall be excavated a minimum of six inches (6") below the pipe bottom in order to receive the required bedding of Class I No. 57 crushed stone. Pipe bedding, haunching and backfilling shall be in accordance with requirements set forth in Section 02210, TRENCHING AND BACKFILLING FOR UTILITIES.

Cleaning Conduit: Clear the interior of conduit of dirt and other superfluous material as the work progresses.

Place plugs in the ends of uncompleted conduit at the end of the day or whenever work stops.

Flush lines between manholes as required to remove collected debris.

Interior Inspection: Inspect conduit to determine whether line displacement or other damage has occurred.

A light held in a manhole shall show a full circle of light when viewed from the adjoining end of the line.

Make inspections after lines between manholes, or manhole locations, have been installed and approximately two feet of backfill is in place and at completion of the project.

If the inspection indicates poor alignment, debris, displaced pipe, infiltration or other defects, take whatever steps are necessary to correct such defects to the satisfaction of the Engineer.

Connection to Existing Structures: Pipe connections to existing structures shall be made in such manner that the finished work will conform as nearly as practicable to the essential applicable requirements specified for new structures, including all necessary concrete work, cutting, and shaping.

END OF SECTION

RELATED DOCUMENTS

Drawings and general provisions of contract, including General and Supplementary Conditions and Division 1 Specification sections that apply to this Section.

PART 1 GENERAL

1.01 SECTION INCLUDES

- A. Galvanized steel ornamental pickets security fencing and swing gates, aluminum cantilevered gates, ramp and steps guardrails with handrails system, and all accessories for complete assemblies.

1.02 RELATED SECTIONS

Section 02830 Chain Link Fence and Gates
Section 02500 Paving and Surfacing.
Section 03300 Cast in Place Concrete.
Section 04200 Unit Masonry.

1.03 SUBMITTALS

- A. Shop Drawings: Layout of fence and gates with dimensions, details, and finishes of component accessories and post foundations.
- B. Product Data: Manufacturer's catalogue cuts indicating material compliance and specified options.
- C. Samples: Color selections for polyester finishes. If requested, samples of materials, (e.g. caps, and accessories).

1.04 WARRANTY

- A. Warranty: The ornamental metal fence and gate systems shall include a written 12-year warranty against defects in materials and workmanship.
- B. Warranty: The ornamental metal fence and gate systems shall include a written 12-year warranty on the coating against cracking, chipping, blistering, peeling or corroding.

PART 2 PRODUCTS

2.01 MANUFACTURER

- A. Equivalent products from other qualified manufacturers having a minimum of 5 years experience manufacturing galvanized steel ornamental picket fencing will be acceptable if they meet the following specifications for design, size, gauge of metal parts and fabrication, upon acceptance by Architect in Accordance with Instructions to Bidders.
 1. Montage Commercial - Steel Ornamental Fence System as manufactured by Ameristar Perimeter Security USA, Inc., Phone (800) 229-5615
 - a. Styles:
 - i. Classic 3-Rail, Height: 6'-0" high from grade

2. Transport II (Classic) Enclosed Track Aluminum Cantilever Slide Gate as manufactured by Ameristar Fence Products, Inc.

2.02 ORNAMENTAL PICKET SECURITY FENCE

- A. Pickets: Square tubular members, ASTM A653/A653M, hot-rolled structural quality steel having a yield strength of 45,000 psi and G60 (hot dipped galvanized) zinc coating, 0.60 oz/ft². Minimum size pickets 3/4" square x 14 gauge .080" wall thickness. Space pickets 4" maximum face to face.
- B. Rails: 14 gauge .080" cold rolled steel. The cross-sectional shape of the rails shall conform to the manufacturer's "Classic" profile design. The cross-sectional outside dimensions of the rails shall be 1.5" x 1.4375". Each rail shall have a minimum weight of 2.55 pounds per foot. Vertical Design Load is 257 Lbs. and Horizontal Design Load is 505 Lbs for 8' Span.

Rails shall be pre-punched to accept pickets.

- C. Posts: Square tubular members, ASTM A653/A653M, hot-rolled structural quality steel, 45,000 psi yield strength, and G60 (hot-dipped Galvanized) zinc coating, 0.60 oz/ft². Minimum post size 2-1/2" square, having 14 gauge wall thickness .080".
- D. The manufactured fence system shall be capable of meeting the vertical load, horizontal load, and infill performance requirements for Commercial weight fences under ASTM F2408.
- E. Galvanized steel fence components shall be prepared with a five-stage wash and pre-treated system, which includes a zinc phosphatizer and a non-chromate sealer. Then receive a two-step powder coating applied by the electrostatic spray process. The base coat shall be a thermosetting epoxy powder coating with a minimum coating thickness of 2 mils. The topcoat shall be a mar-resistant acrylic powder coating with a minimum coating thickness of 2 mils.
- F. Color: Black.

2.03 GATES – Swing and Cantilevered Sliding Gate Systems

- A. Ornamental picket swing gates shall be fabricated using same materials as Classic style fencing system. All rail and upright intersections shall be joined by welding. All picket and rail intersections shall be joined by welding.
- B. Ornamental picket aluminum cantilever slide gates, Ameristar Transport II gate system, with enclosed aluminum track and hardware, manually operated, fabricated using same materials as Classic style fencing system. Provide dual track assembly for gates widths exceeding 30 feet.
- C. Compliant with:

Gate Framing and Rails: ASTM B221 Aluminum designation 6063-T-6 with yield strength of 25,000 psi, and tensile strength of 30,000 psi

- a. GATE FRAMES: Fabricated in accordance with ASTM F 1184 Type II Class 2. Vertical frame members shall be 2 inch square aluminum, with a 0.25" wall thickness and weighing 1.12 lbs./ft. Top track/frame member shall be a one-piece aluminum extrusion, weighing a minimum of 4.62 lbs./ft. for single track and 7.95 for lbs./ft. for dual track. Aluminum alloy used shall be 6061-T6 only. Intermediate uprights shall be 2-inch square aluminum spaced equally at no more than 6 feet o.c. subdividing the gate frame into panels. All members shall be welded to form a rigid one-piece gate frame unit.
- b. PICKETS shall be 1" x 1/8" wall thickness.

- c. DIAGONAL BRACING shall be 2" x 1/4" aluminum.
- d. FABRIC FILLER: Shall match fence and be attached to the frame by means of hook bolts. Fabric shall be attached between each internal upright with hook bolts spaced no more than 15 inches o.c. as recommended by the manufacturer.
- e. TRUSSING: Each bay shall be cross-trussed by means of 1/4" galvanized cable, 2,200 lbs. rated breaking strength, and adjustable turnbuckles bolted to corner gussets. Cable trussing will maintain the structural integrity of the gate while allowing for expansion and contraction of aluminum during various weather conditions.
- f. TRUCK ASSEMBLIES: Shall be swivel type, zinc coated steel, with six (6) factory sealed and lubricated ball bearing rollers. Four vertical rollers shall be 2 inches in diameter x 9/16-inch in width and two ball bearing zinc plated steel side rollers to prevent lateral movement. Truck assemblies shall be mounted on post brackets using 7/8-inch diameter Clevis bolts with a 9/16-inch shank.
- g. BOTTOM GUIDE WHEEL ASSEMBLIES: Two 3 inch diameter wheels (one set) straddling the bottom horizontal gate rail shall be installed, one set on the gate post and one on the overhang post.
- h. END PLUG: After gate has been installed, both ends of the combination track/frame member shall be closed off with a shock-absorbing block bolted through the frame. The bottom 2" x 4" horizontal rail shall also have both ends completely closed with aluminum plate that has been continuously welded into place at the factory.
- i. HARDWARE: Gate hangers, latches, brackets and guide assemblies shall be steel, galvanized after fabrication. A positive latch device shall be provided with provisions for padlocking.
- j. POSTS: Gate posts, latch posts and overhang posts shall be 4 inches O.D. Schedule 40 galvanized pipe, 2 pairs of connected support posts for each leaf for gates 31'-0" or larger. Provide one 4" latch post.

Set posts in 12 inches x 36 inches deep concrete footings or as recommended by the manufacturer. Concrete shall be sloped to shed water away from the posts.
- k. STYLE: Style of gate frame shall be single or dual track, dictated by size of opening as recommended by manufacturer.
- l. CERTIFICATION: Mill certificates verifying that the 6061-T6 alloy has been used and that all other components of this specification have been met are required.
- m. SPECIAL WARRANTY: Provide manufacturer's standard limited warranty covering cantilevered slide gate and truck assemblies against failure resulting from normal use for a period of 5 years from date of accepted installation. Failure is defined as any defect in manufacturing that prevents the gate from operating in a normal manner.
- n. COLOR: Black

D. CERTIFICATIONS

- a. American Welding Society AWS D1.2 Structural Welding Code
- b. All welds on the gate frame shall conform to Welding Procedure Specification and Procedure Qualification Record to insure conformance to the AWS D1.2 Structural Welding Code. All individual welders shall be certified to AWS D1.2 welding code.

- c. Gate manufacturer shall provide independent certification as to the use of a documented Welding Procedure Specification and Procedure Qualification Record to insure conformance to the AWS D1.2 welding code. Upon request, Individual Certificates of Welder Qualification documenting successful completion of requirements of the AWS D1.2 code shall also be provided.

2.04 ACCESSORIES

Provide all necessary accessories and components for a complete operational assemblies.

- A. Pickets, rails and posts shall be cut to specified lengths. Rails shall be punched to accept pickets. Pickets shall be drilled to accept retaining rods. Cutting, punching and drilling shall be done prior to coating to facilitate assembly without compromising the integrity of the finish.
- B. Rubber grommets shall be inserted into the pre-punched holes in the rails. Pickets shall be inserted through the grommets so that the pre-drilled holes in the pickets align with the internal upper raceway of the rails.
- C. Completed sections shall be capable of supporting a 600 pound load at mid-span without permanent deformation.
- D. A 1/8" diameter galvanized steel retaining rod shall then be inserted into the upper raceway of the rails through the pre-drilled holes in each picket.
- E. Posts shall have a square cap firmly affixed to the extending end.
- F. Picket Tops: Classic 3-Rail

2.05 SETTING MATERIALS

- A. Concrete: Minimum 28 days compressive strength of 3000psi.
- B. Flanged Posts: Provide flange type base plates with 4 holes for surface mounting of posts where indicated.

2.06 RAILINGS AT RAMPS & STEPS

Provide all necessary accessories and components for powder-coated welded aluminum picket railings complete Guard Rail and Stair Rails system, by EXCELL Railing Systems Ltd.

Fully tested to AC273. Code compliant with IBC 2015 and NBC 2010.

- A. Pickets, rails and posts shall be cut to specified lengths, welded to top and bottom rails. Rails shall be punched to accept pickets. Cutting, punching and drilling shall be done prior to coating to facilitate assembly without compromising the integrity of the finish.
- B. Panel Style 01; with NEW Port Royal Top Rail, Excell Square Top Rail profile, at height indicated on Drawings.
- C. Posts mounted as indicated on Drawings.
- D. Provide 1 1/2" dia. welded aluminum handrails as indicated on Drawings.
- E. Architect to select color from minimum of 12 standard colors.
- F. Provide with manufacturer's 20-year structural warranty and manufacturer's 10-year powder coating warranty.

PART 3 EXECUTION

3.01 EXAMINATION

- A. Verify areas to receive fencing and gates are completed to final grades and elevations.
- B. Verify areas to assure sufficient space to receive gate in open position (gate and overhang).
- C. Ensure property lines and legal boundaries of work are clearly established.

3.02 INSTALLATION

- A. Install fences in accordance with manufacturer's instructions.
- B. Concrete Set Posts: Drill 36" deep hole in firm, undisturbed or compacted soil, for minimum 36" post embedment. Set gate posts for gate opening specified in the construction drawings.
 - 1. Gate Posts and Hardware: Set keepers, stops, sleeves and other accessories into concrete.
- C. Surface mount (wall mount) posts with mounting plates where indicated. Fasten with lag bolts and shields.
- D. Check each post for vertical and top alignment, and maintain in position during placement and finishing operation.
- E. Attach fence panels to posts using brackets supplied by the manufacturer.

3.03 SWING GATE INSTALLATION

- A. Install swing gates in accordance with manufacturer's instructions.
- B. Install gates plumb, level and secure for full opening without interference.
- C. Attach hardware by means which will prevent unauthorized removal.
- C. Adjust hardware for smooth operation.

3.04 SLIDING GATE INSTALLATION

- A. Install slide gates in accordance with manufacturer's instructions, conforming to all applicable federal, state, and local codes, and in accordance with ASTM F-567 and F-1184.
- B. Install "Fall-over" posts per ASTM F-1184 and ASTM F-2200 (Section 4.2) to prevent fall of more than 45 degrees from the vertical plane if gate should disengage from mounting hardware.
- C. Concrete set gate posts: Drill holes in firm, undisturbed or compacted soil. Holes shall have diameter 4 times greater than outside dimension of post with a minimum diameter of 12", and depths approximately 6" inches deeper than post bottom with a minimum depth of 42" per ASTM F-567 (Section 5.13.1). Excavate deeper as required for adequate support in soft and loose soils, and for posts with heavy lateral loads. Set post bottom 42" below surface when in firm, undisturbed soil. Place concrete around posts in a continuous pour, tamp for consolidation. Trowel finish around post and slope to direct water away from posts. Check each post for vertical and top alignment, and maintain in position during placement and finishing operations.

- D. Install gates plumb, level, and secure for full opening without interference. Gate movement shall not be initiated by gravity.
- E. Attach hardware by means which will prevent unauthorized removal.
- F. Adjust gate and hardware for smooth operation.

3.05 CLEANING

- A. Clean up debris and unused material, and remove from site.
- B. Touch up all scratches and nicks with manufacturer's galvanized paint and matching topcoats.

RELATED DOCUMENTS:

Drawings and general provisions of Contract, including General and Supplementary Conditions and Division-1 Specification sections, apply to work of this section.

CHAIN LINK FENCING AND WELDED GATES:

Provide black PVC coated galvanized chain link fences and welded gates as complete units controlled by a single source including necessary erection accessories, fittings, fastenings and weldments.

Product Data: Submit manufacturer's technical product data, and installation instructions for metal fencing, fabric, gates and accessories.

Dimensions indicated for pipe, roll-formed, and H-sections are outside dimensions, exclusive of coatings.

Manufacturer: Subject to compliance with requirements, provide products of one of the following:

Black PVC Coated Galvanized Steel Fencing and Fabric:

Hoover Fence Co.

Allied Tube and Conduit Corp.

American Fence Corp.

Anchor Fence, Inc.

Black PVC Coated Galvanized Steel Fencing:

Fabric: No. 9 ga. (0.148") finished size steel wires, 2" mesh, with top selvages knuckled for fabric 60" high and under, and both top and bottom selvages twisted and barbed for fabric over 60" high. Tennis court mesh to be 9 ga. X 1 3/4" mesh.

Fabric finish: Minimum 7 mil black PVC thermally bonded coating over galvanized, ASTM A 392, Class I, with not less than 1.2 oz. zinc per sq. ft. of surface.

Furnish one piece fabric widths for fencing up to 12' high.

Framework: Minimum 7 mil black PVC thermally bonded coating over galvanized steel, ASTM A 120 or ASTM A 123, with not less than 1.8 oz. zinc per sq. ft. of surface.

Fittings and Accessories: Minimum 7 mil black PVC thermally bonded coating over galvanized, ASTM A 153, with zinc weights per Table I.

Framing and Accessories:

End, Corner, and Pull Posts: Minimum sizes and weights as follows:

- Up to 6' fabric height, 2.375" od steel pipe, 3.65 lbs. per lin. ft., or 3.5" x 3.5" roll-formed sections, 4.85 lbs. per lin. ft.
- Over 6' fabric height, 2.875" od steel pipe, 5.79 lbs. per lin. ft., or 3.5" roll-formed sections, 4.85 lbs. per lin. ft.

Line Posts: Space 10' o.c. maximum, unless otherwise indicated, of following minimum sizes and weights.

- Up to 6' fabric height, 1.90" od steel pipe, 2.70 lbs. per lin. ft. or 1.875" x 1.625" C sections, 2.28 lbs. per lin. ft.
- Over 6' to 8' fabric height, 2.375" od steel pipe, 3.65 lbs. per lin. ft. or 2.25" x 1.875" H-sections, 2.64" lbs. per lin. ft.
- Over 8' fabric height, 2.875" od steel pipe, 5.79 lbs. per lin. ft. or 2.25" x 1.875" H-sections, 3.26 lbs. per lin. ft.

Gate Posts: Furnish posts for supporting single gate leaf, or one leaf of a double installation, for nominal gate widths as follows:

<u>Leaf Width</u>	<u>Gate Post</u>	<u>lbs. / lin. ft.</u>
• Up to 6'	3.5" x 3.5" roll-formed section or 2.875" od pipe	4.85 5.79
• Over 6' to 13'	4.000" od pipe	9.11
• Over 13' to 18'	6.625" od pipe	18.97
• Over 18'	8.625" od pipe	28.55

Top Rail: Manufacturer's longest lengths, with expansion type couplings, approximately 6" long, for each joint. Provide means for attaching top rail securely to each gate corner, pull and end post.

1.66" od pipe, 2.27 lbs. per ft. or 1.625" x 1.25" roll-formed sections, 1.35 lbs. per ft.

Tension Wire: 7-gage, coated coil spring wire, metal and finish to match fabric.

Locate at bottom of fabric.

Post Brace Assembly: Manufacturer's standard adjustable brace at end and gate posts and at both sides of corner and pull posts, with horizontal brace located at mid-height of fabric. Use same material as top rail for brace, and truss to line posts with 0.375" diameter rod and adjustable tightener.

Post Tops: Provide weathertight closure cap with loop to receive tension wire or top rail; one cap for each post.

Stretcher Bars: One-piece lengths equal to full height of fabric, with minimum cross-section of 3/16" x 3/4". Provide one stretcher bar for each gate and end post, and 2 for each corner and pull post, except where fabric is integrally woven into post.

Stretcher Bar Bands: Space not over 15" o.c., to secure stretcher bars to end, corner, pull, and gate posts.

Gates: Fabricate fully welded perimeter frames of gates from metal and finish to match fence framework. Assemble gate frames only by welding all connections, providing security against removal and breakage of connections. Provide horizontal and vertical members to ensure proper gate operation and attachment of fabric, hardware and accessories. Space frame members maximum of 8' apart unless otherwise indicated.

Provide same fabric as for fence, unless otherwise indicated. Install fabric with stretcher bars at vertical edges and at top and bottom edges. Attach stretcher bars to gate frame at not more than 15" o.c.

Install diagonal cross-bracing consisting of 3/8" diameter adjustable length truss rods on gates to ensure frame rigidity without sag or twist.

Where barbed wire is indicated above gates, extend end members of gate frames 1'-0" above top member. Provide necessary clips to receive and secure 3 strands of wire.

Swing Gates: Fabricate perimeter frames of minimum 1.90" od pipe.

Gate Hardware: Provide hardware and accessories for each gate, galvanized per ASTM A 153, and in accordance with the following:

- Hinges: Size and material to suit gate size, non-lift-off type, offset to permit 180° gate opening. Provide 1-1/2 pair of hinges for each leaf over 6' nominal height.
- Latch: Forked type or plunger-bar type to permit operation from either side of gate, with padlock eye as integral part of latch.

Double Gates: Provide gate stops for double gates, consisting of mushroom type flush plate with anchors, set in concrete, and designed to engage center drop rod or plunger bar.

Include locking device and padlock eyes as integral part of latch, permitting both gate leaves to be locked with single padlock.

Gate Egress and Security Hardware: Where indicated on Drawings, provide weather resistant Surface Mount Exit Bar Kit, equal to D-6040-S by Hoover. Assembly shall include: exit bar device, 24" adjustable mounting plate, adjustable receiver bracket, lock box with solid brass keyed cylinder and two keys for 5-pin Schlage keyway, stainless steel anchors and fasteners. Silver powder coated finish.

Sliding Gates (fully welded frames): Provide manufacturer's standard heavy-duty inverted channel track, ball-bearing hanger sheaves, overhead framing and supports, guides, stays, bracing, hardware, and accessories as required.

Wire Ties: For tying fabric to line posts, use wire ties spaced 12" o.c. For tying fabric to rails and braces, use wire ties spaced 24" o.c. For tying fabric to tension wires, use hog rings spaced 24" o.c.

Manufacturer's standard procedure will be accepted if of equal strength and durability.

Concrete: Provide concrete consisting of portland cement, ASTM C 150, aggregates ASTM C 33, and clean water. Mix materials to obtain concrete with a minimum 28-day compressive strength of 3000 psi using at least 4 sacks of cement per cu. yd., 1" minimum size aggregate, maximum 3" slump, and 2% to 4% entrained air.

Excavation: If not shown on drawings, excavate holes to minimum depth and diameter as recommended by fence manufacturer.

Installation: Install in accordance with ASTM F 567 and written installation instructions of fencing manufacturer to provide secure, aligned installation.

END OF SECTION

RELATED DOCUMENTS:

The general provisions of the Contract, including General and Supplementary Conditions, and General Requirements, and Division 1 specifications that apply to the work specified in this Section.

Part 1: GENERAL

1.01 Description

- A. Work shall consist of designing, furnishing and construction of a concrete segmental retaining wall system in accordance with these specifications and in conformity with the lines, grades, design and dimensions shown on the plans.
- B. Work includes preparing foundation soil, furnishing and installing leveling pad, unit facing system, unit drainage fill and reinforced backfill to the lines and grades shown on the construction drawings.
- C. Work includes furnishing and installing geogrid soil reinforcement of the type, size, location and lengths designated on the construction drawings.

1.02 Related Sections

- A. Section 02200 – Earthwork
- B. Section 02210 - Site Clearing

1.03 Reference Documents

- A. American Association of State Highway and Transportation Officials (AASHTO)
 - 1. AASHTO M 252 Corrugated Polyethylene Drainage Pipe
 - 2. AASHTO M 288 Geotextile Specification for Highway Applications
- B. American Society for Testing and Materials (ASTM)
 - 1. ASTM C140 Sampling and Testing Concrete Masonry Units
 - 2. ASTM C1372 Specification for Dry-Cast Segmental Retaining Wall Units
 - 3. ASTM D442 Particle Size Analysis of Soils
 - 4. ASTM D698 Laboratory Compaction Characteristics of Soil – Standard Effort
 - 5. ASTM D1556 Standard Test Method for Density and Unit Weight of Soil In Place by the Sand Cone Method
 - 6. ASTM D1557 Laboratory Compaction Characteristics of Soil – Modified Effort
 - 7. ASTM D2487 Standard Classification of Soils for Engineering Purposes (Unified Soil Classification System)
 - 8. ASTM D2922 Standard Test Methods for Density of Soil and Soil-Aggregate in Place by Nuclear Methods (Shallow Depth)
 - 9. ASTM D3034 Standard Specification for Type PSM Poly (Vinyl Chloride) (PVC) Sewer pipe and Fittings
 - 10. ASTM D4318 Liquid Limit, Plastic Limit and Plasticity Index of Soils
 - 11. ASTM D4475 Horizontal Shear Strength of Pultruded Reinforced Plastic Rods
 - 12. ASTM D4476 Flexural Properties of Fiber Reinforced Pultruded Plastic Rods
 - 13. ASTM D4595 Standard Test Method for Tensile Properties of Geotextiles by Wide-Width Strip Method
 - 14. ASTM D4873 Standard Guide for Identification, Storage and Handling of Geosynthetics

15. ASTM D5262 Standard Test Method for Evaluating the Unconfined Tension Creep Behavior of Geosynthetics
16. ASTM D5321 Standard Test Method for Determining the Coefficient of Soil and Geosynthetic or Geosynthetic and Geosynthetic Friction by the Direct Shear Method
17. ASTM D5818 Standard Practice for Obtaining Samples of Geosynthetics from a Test Section for Assessment of Installation Damage
18. ASTM D6637 Standard Test Method for Determining Tensile Properties of Geogrids by the Single or Multi-Rib Method
19. ASTM D6638 Standard Test Method for Determining Connection Strength Between Geosynthetic Reinforcement and Segmental Concrete Units
20. ASTM D6706 Standard Test Method for Measuring Geosynthetic Pullout Resistance in Soil
21. ASTM D6916 Standard Test Method for Determining the Shear Strength Between Segmental Concrete Units

C. National Concrete Masonry Association (NCMA)

1. NCMA SRWU-1 Test Method for Determining Connection Strength of SRW
2. NCMA SRWU-2 Test Method for Determining Shear Strength of SRW

1.04 Definitions

- A. Compac II Unit – a dry-stacked concrete retaining wall unit machine made from Portland cement, water, aggregates, manufactured by a licensed manufacturer of Keystone.
- B. Structural Geogrid – a polymeric material formed by a regular network of connected tensile elements with apertures of sufficient size to allow interlocking with surrounding soil, rock or earth and function primarily as reinforcement.
- C. Unit Drainage Fill – drainage aggregate that is placed within and immediately behind the Keystone concrete units.
- D. Reinforced Backfill – compacted soil that is placed within the reinforced soil volume as outlined on the plans.
- E. Retained Soil – the soil mass behind the reinforced backfill.
- F. Foundation Soil – the soil mass below the leveling pad and reinforced backfill.
- G. Leveling Pad – crushed stone, sand and gravel or unreinforced concrete material placed to provide a level surface for placement of the Keystone concrete units.
- H. Geosynthetic Reinforcement – polymeric material designed specifically for soil reinforcement.

1.05 Submittals and Certification

- A. Contractor shall submit a Manufacturer's certification, prior to the start of work, that the retaining wall system components meet the requirements of this specification and the structure design.
- B. Contractor shall submit construction drawings and design calculations for the retaining wall system prepared and stamped by a Professional Engineer registered in the state of the project.

1.06 Quality Assurance

- A. Contractor shall submit a list of five (5) previously constructed projects of similar size and magnitude by the wall installer where the Compac retaining wall system has been constructed successfully. Contact names and phone numbers shall be listed for each project.
- B. Contractor shall provide evidence that the design engineer has a minimum of five years documented experience in the design of reinforced soil structures. The design engineer shall provide proof of current professional liability insurance with an aggregate coverage limit of not less than \$2,000,000.
- C. Owner shall/may provide quality assurance inspection and testing during earthwork and wall construction operations. Contractor shall provide all quality control testing and inspection not provided by the owner. Owner's quality assurance program does not relieve the contractor of responsibility for quality control and wall performance.

1.07 Delivery Handling and Storage

- A. Contractor shall check all materials upon delivery to assure that the proper type, grade, color, and certification have been received.
- B. Contractor shall protect all materials from damage due to jobsite conditions and in accordance with manufacturer's recommendations. Damaged materials shall not be incorporated into the work.

PART 2: PRODUCTS

2.01 Manufacturers Standard: For purpose of designating type and quality for work under this Section, Drawings and Specifications are based on products manufactured Keystone Retaining Walls. Rockwood Retaining Wall Systems equivalent products or systems of same materials specified will be accepted.

2.02 Keystone Concrete Retaining Wall Units

- A. Compac II retaining wall units shall conform to the following architectural requirements
 - 1. Face color: The Architect will select color from standard manufacturers' color.
 - 2. Straight Face finish - hard split in straight face configuration. Other face finishes will not be allowed without written approval of Owner.
 - 3. Bond configuration - running with bonds nominally located at midpoint in vertically adjacent units.
 - 4. Exposed surfaces of units shall be free of chips, cracks or other imperfections when viewed from a distance of 20 feet (6 m) under diffused lighting.
- B. Concrete retaining wall units shall conform to the requirements of ASTM C1372 - Standard Specifications for Segmental Retaining Wall Units.
- C. Concrete retaining wall units shall conform to the following structural and geometric requirements measured in accordance with ASTM C140 Sampling and Testing Concrete Masonry Units:
 - 1. Compressive strength: ≥ 3000 psi (21 MPa).
 - 2. Absorption: ≤ 8 % for standard weight aggregates.
 - 3. Dimensional tolerances: $\pm 1/8$ " (3 mm) from nominal unit dimensions not including rough split face.

4. Unit Size: 8" (203 mm) (H) x 18" (457 mm) (W) x 12" (304 mm)(D) minimum.
- D. Concrete retaining wall units shall conform to the following constructability requirements:
1. Vertical setback: 1/8 inch (3 mm) ± per course (near vertical) or 1 1/8 inch (28 mm) + per course, per the design.
 2. Alignment and grid attachment mechanism - fiberglass pins, two per unit.
 3. Maximum horizontal gap between erected units shall be ≤ 1/2 inch (13 mm).

2.03 Shear and Reinforcement Pin Connectors

- A. Shear and reinforcement pin connectors shall be 1/2-inch (12 mm) diameter thermoset isophthalic polyester resin pultruded fiberglass reinforcement rods to provide connection between vertically and horizontally adjacent units and geosynthetic reinforcement, with the following requirements:
1. Flexural Strength in accordance with ASTM D4476: 128,000 psi (882 MPa) minimum.
 2. Short Beam Shear in accordance with ASTM D4475: 6,400 psi (44 MPa) minimum.
- B. Shear and reinforcement pin connectors shall be capable of holding the geogrid in the proper design position during grid pre-tensioning and backfilling.

2.04 Base Leveling Pad Material

- A. Material shall consist of a compacted crushed stone base, sand and gravel or unreinforced concrete, as shown on the construction drawings.

2.05 Unit Drainage Fill

- A. Unit drainage fill shall consist of clean 1 inch (25 mm) minus crushed stone or crushed gravel meeting the following gradation tested in accordance with ASTM D-422:

<u>Sieve Size</u>	<u>Percent Passing</u>
1 inch (25 mm)	100
3/4-inch (19mm)	75 – 100
No. 4 (4.75 mm)	0 – 10
No. 50 (300 um)	0 - 5

- B. Drainage fill shall be placed within the cores of, between, and behind the units as indicated on the design drawings. Not less than 1.3 cubic foot (0.036 m³), of drainage fill shall be used for each square foot (0.093 m²) of wall face unless otherwise specified.

2.06 Reinforced Backfill

- A. Reinforced backfill shall be free of debris and meet the following gradation tested in accordance with ASTM D-422:

<u>Sieve Size</u>	<u>Percent Passing</u>
1 1/2 inch (38 mm)	100
3/4-inch (19 mm)	75 – 100
No. 40 (425 um)	0 – 60
No. 200 (75 um)	0 – 35

Plasticity Index (PI) < 15 and Liquid Limit < 40, per ASTM D4318

- B. The maximum aggregate size shall be limited to 3/4 inch (19 mm) unless installation damage tests have been performed to evaluate potential strength reductions to the geogrid design due to increased installation damage during construction.
- C. Material can be site-excavated soils where the above requirements can be met. Soils not meeting the above criteria, including highly plastic clays and organic soils, shall not be used in the backfill or reinforced backfill soil mass.
- D. Contractor shall submit reinforced fill sample and laboratory test results to the Architect/Engineer for approval, prior to the use of any proposed reinforced backfill material.

2.07 Geogrid Soil Reinforcement

- A. Geosynthetic reinforcement shall consist of geogrids manufactured for soil reinforcement applications and shall be manufactured from high tenacity polyester yarn or high density polyethylene. Polyester geogrid shall be made from high tenacity polyester filament yarn with a molecular weight exceeded 25,000 g/m and with a carboxyl end group value less than 30. Polyester geogrid shall be coated with an impregnated PVC coating that resists peeling, cracking and stripping.
- B. T_a – Long Term Allowable Tensile Design Load. T_a of the geogrid material shall be determined as follows: $T_a = T_{ult}/(RF_{cr} * RF_d * RF_{id} * FS)$. T_a shall be evaluated based on a 75 year design life.
 - 1. T_{ult} – Short Term Ultimate Tensile Strength. T_{ult} shall be determined in accordance with ASTM D4595 or ASTM D6637. T_{ult} is based on the minimum average roll values (MARV).
 - 2. RF_{cr} – Reduction Factor for Long Term Tension Creep. RF_{cr} shall be determined from 10,000 hour creep testing performed in accordance with ASTM D5262. $RF_{cr} = 1.45$ minimum.
 - 3. RF_d – Reduction Factor for Durability. RF_d shall be determined from polymer specific durability testing covering the range of expected soil environments. $RF_d = 1.10$ minimum.
 - 4. RF_{id} – Reduction Factor for Installation Damage. RF_{id} shall be determined from product specific construction damage testing performed in accordance with ASTM D5818. Test results shall be provided for each product to be used with project specific or more severe soil types. $RF_{id} = 1.05$ minimum.
 - 5. FS – Overall Design Factor of Safety. FS shall be 1.5 unless noted for the maximum allowable working stress calculation.
- C. The maximum design tensile load of the geogrid shall not exceed the laboratory tested ultimate strength of the geogrid/facing unit connection divided by a factor of safety of 1.5. The connection strength testing and computation procedures shall be in accordance with ASTM D6638 Connection Strength between Geosynthetic Reinforcement and Segmental Concrete Units or NCMA SRWU-1.
- D. C_i – Coefficient of Soil Interaction. C_i values shall be determined per ASTM D6706 at a maximum 0.75 inch (19 mm) displacement.

- E. The geogrid manufacturer shall have a Manufacturing Quality Control program that includes QC testing by an independent laboratory. The QC testing shall include Tensile Strength testing, Melt Flow Index testing for HDPE geogrids and Molecular Weight testing for polyester geogrids.

2.08 Drainage Pipe

- A. If required, drainage pipe shall be perforated or slotted PVC pipe manufactured in accordance with ASTM D3034 or corrugated HDPE pipe manufactured in accordance with AASHTO M252.

2.09 Geotextile Filter Fabric

- A. When required, geotextile filter fabric shall be a needle-punched nonwoven fabric that meets the requirements of AASHTO M288.

PART 3: EXECUTION

3.01 Excavation

- A. Contractor shall excavate to the lines and grades shown on the construction drawings. The Owner or Contractors QA/QC representative shall inspect the excavation and test the foundation soils and approve prior to placement of the leveling pad material or fill soils. Any over-excavation required to remove unsuitable soils shall be oversized from the front of the leveling pad and back of the geogrid reinforcement.
- B. Over-excavation and replacement of unsuitable soils and replacement with approved compacted fill will be compensated as agreed upon with the Owner.

3.02 Base Leveling Pad

- A. Leveling pad material shall be placed to the lines and grades shown on the construction drawings to a minimum thickness of 6 inches (150 mm) and extend laterally a minimum of 6 inches in front and behind the Keystone wall unit.
- B. Soil leveling pad materials shall be compacted to a minimum of 95% of Standard Proctor density per ASTM D697 or 92% Modified Proctor density per ASTM D1557.
- C. Leveling pad shall be prepared to insure full contact with the base surface of the concrete units.

3.03 Unit Installation

- A. First course of units shall be placed on the leveling pad at the appropriate line and grade. Alignment and level shall be checked in all directions and insure that all units are in full contact with the base and properly seated.
- B. Place the front of units side-by-side. Do not leave gaps between adjacent units. Layout of corners and curves shall be in accordance with manufacturer's recommendations.
- C. Install shear/connecting pins per manufacturer's recommendations.

- D. Place and compact drainage fill within and behind wall units. Place and compact reinforced backfill soil behind drainage fill.
- E. Maximum stacked vertical height of wall units, prior to drainage fill and backfill placement and compaction, shall not exceed two courses.

3.04 Structural Geogrid Installation

- A. Geogrid shall be installed with the highest strength direction perpendicular to the wall alignment.
- B. Geogrid reinforcement shall be placed at the strengths, lengths and elevations shown on the construction drawings, or as directed by the engineer.
- C. The geogrid shall be laid horizontally on compacted backfill and attached to the Keystone wall unit pins and within 1 inch of the face of the units. Place the next course of Keystone units over the geogrid. The geogrid shall be pulled taut and anchored prior to backfill placement on the geogrid.
- D. Geogrid reinforcements shall be continuous throughout their embedment lengths and placed side-by-side to provide 100% coverage at each level. Spliced connections between shorter pieces of geogrid or gaps greater than 2 inches between adjacent pieces of geogrid are not permitted.

3.05 Reinforced Backfill Placement

- A. Reinforced backfill shall be placed, spread and compacted in such a manner that minimizes the development of slack in the geogrid and installation damage to the geogrid.
- B. Reinforced backfill shall be placed and compacted in lifts not to exceed 6 inches (150 mm) where hand operated compaction equipment is used, or 8 – 10 inches (200 to 250 mm) where heavy compaction equipment is used. Lift thickness shall be decreased to achieve the required density, as needed.
- C. Reinforced backfill shall be compacted to a minimum of 95% of Standard Proctor density per ASTM D697 or 92% Modified Proctor density per ASTM D1557. The moisture content of the reinforced backfill material during compaction shall be uniformly distributed throughout each layer and shall be dry of optimum by 0 to 3 percentage points of moisture.
- D. Only hand operated compaction equipment shall be allowed within 3 feet (1 M) from the back of the Keystone concrete units.
- E. Tracked construction equipment shall not be operated directly upon the geogrid reinforcement. A minimum fill thickness of 6 inches (150 mm) is required prior to operation of tracked vehicles over the geogrid. Tracked vehicle turning should be kept to a minimum to prevent tracks from displacing the fill and damaging or displacing the Keystone units or geogrid.
- F. Rubber tired equipment may pass over geogrid reinforcement at slow speeds, less than 10 MPH. Sudden braking and turning shall be avoided.

- G. At the end of each day's operation, the Contractor shall slope the last lift of reinforced backfill away from the wall units to direct runoff away from the wall face. The Contractor shall not allow surface runoff from adjacent areas to enter the wall construction site.

3.06 Cap Installation

- A. Prior to placement of the cap units, the upper surface of the top course of wall units shall be cleaned of soil and any other material.
- B. Cap units shall be adequately glued to the underlying wall units with an all-weather exterior construction adhesive.

3.07 As-built Construction Tolerances

- A. Vertical alignment: ± 1.5 inches (40 mm) over any 10 foot (3 m) distance.
- B. Wall batter: within 2 degrees of design batter. Overall wall batter shall be ≥ 0 degrees.
- C. Horizontal alignment: ± 1.5 inches (40 mm) over any 10 foot (3 m) distance.
- D. Corners and curves: ± 1 foot (300 mm) to theoretical location.
- E. Maximum horizontal gap between erected units shall be $\leq 1/2$ inch (13 mm).

3.08 Field Quality Control

- A. Quality Assurance – The owner shall/may engage inspection and testing services, including independent laboratories, to provide quality assurance and testing services during construction. This does not relieve the Contractor from securing the necessary construction quality control testing.
- B. Quality assurance should include foundation soil inspection and testing and verification of the geotechnical design parameters and verification that the contractor's quality control testing is adequate as a minimum. Quality assurance shall also include observation of the construction for general compliance with the design drawings and project specifications. Quality assurance is usually best performed by the site geotechnical engineer.
- C. Quality Control – The Contractor shall engage independent inspection and testing services to perform the minimum quality control testing described in the retaining wall design plans and specifications. Only qualified and experienced technicians and engineers shall perform quality control testing and inspection services.
- D. Quality control testing shall include soil and backfill testing to verify soil types and strengths, compaction and moisture conditions and verification that the retaining wall is being constructed in accordance with the design plans and specifications.

END OF SECTION

RELATED DOCUMENTS:

Drawings and general provisions of Contract, including General and Supplementary Conditions and Division-1 Specification sections, apply to work of this section.

PART 1: GENERAL

1.1 SECTION INCLUDES

- A. Formwork for cast—in place concrete, with shoring, bracing and anchorage.
- B. Openings for other work.
- C. Form accessories.
- D. Form stripping.

1.2 RELATED SECTIONS

- A. Section 03200 — Concrete Reinforcement.
- B. Section 03300 — Cast-in-Place Concrete.

1.3 REFERENCES

- A. ACI 301 — Structural Concrete for Buildings.
- B. ACI 318 — Building Code Requirements for Reinforced Concrete.
- C. PS 1 — Construction and Industrial Plywood.

1.4 DESIGN REQUIREMENTS

- A. Design and construct formwork, shoring and bracing to conform to design and code requirements; resultant concrete to conform to required shape, line and dimension.

1.5 QUALITY ASSURANCE

- A. Perform Work in accordance with ACI 301 and 318.
- B. Maintain one copy of each document on site.

1.6 REGULATORY REQUIREMENTS

- A. Conform to ACI 301 and ACI 318 code for design, fabrication, erection and removal of formwork.

1.7 DELIVERY, STORAGE, AND HANDLING

- A. Deliver, store, protect and handle products to site to prevent damage.
- B. Store off ground in ventilated and protected manner to prevent deterioration from moisture.

1.8 COORDINATION

- A. Coordinate this Section with other Sections of work which require attachment of components to formwork.
- B. If formwork is placed after reinforcement resulting in insufficient concrete cover over reinforcement before proceeding, request instructions from Architect/Engineer.

PART 2: PRODUCTS

2.1 WOOD FORM MATERIALS

- A. Plywood: Douglas Fir; solid one side, tight faced undamaged sheets with clean, true edges.

2.2 MANUFACTURERS — PREFABRICATED FORMS

- A. Symons or equal.

2.3 PREFABRICATED FORMS

- A. Preformed Steel Forms: Minimum 16 gage, matched, tight fitting, stiffened to support weight of concrete without deflection detrimental to tolerances and appearance of finished surfaces.
- B. Steel Tubular Column Type: Round, steel material, minimum 16 gage, surface treated with release agent, of sizes required.

2.4 FORMWORK ACCESSORIES

- A. Form Ties: Snap—off type, galvanized metal, cone type, with waterproofing washer.
- B. Form Release Agent: Colorless mineral oil which will not stain concrete, or absorb moisture.
- C. Dovetail Anchor Slot: Galvanized steel, 22 gage, foam filled.
- D. Flashing Reglets: Galvanized steel, 22 gage, longest possible lengths, with alignment splines for joints, foam filled,
- E. Nails, Spikes, Lag Bolts, Through Bolts, Anchorages: Sized as required, of sufficient strength and character to maintain formwork in place while placing concrete.
- F. Waterstops: Hydrophylic type as manufactured by American Colloid or approved equal.

PART 3: EXECUTION

3.1 EXAMINATION

- A. Verify lines, levels and centers before proceeding with formwork. Ensure that dimensions agree with drawings.

3.2 EARTH FORMS

- A. Hand trim sides and bottom of earth forms. Remove loose soil, mud, and debris prior to placing concrete.

3.3 ERECTION — FORMWORK

- A. Erect formwork, shoring and bracing to achieve design requirements, in accordance with requirements of ACI 301.

- B. Provide bracing to ensure stability of formwork. Shore or strengthen formwork subject to over stressing by construction loads.
- C. Arrange and assemble formwork to permit dismantling and stripping. Do not damage concrete during stripping. Permit removal of remaining principal shores.
- D. Align joints and make watertight. Keep form joints to a minimum.
- E. Obtain approval before framing openings in structural members which are not indicated on Drawings.
- F. Provide chamfer strips on exposed external corners.

3.4 APPLICATION — FORM RELEASE AGENT

- A. Apply form release agent on formwork in accordance with manufacturer's recommendations.
- B. Apply prior to placement of reinforcing steel, anchoring devices, and embedded items.
- C. Do not apply form release agent where concrete surfaces will receive special finishes or applied coverings which are affected by agent. Soak inside surfaces of untreated forms with clean water. Keep surfaces coated prior to placement of concrete.

3.5 INSERTS, EMBEDDED PARTS, AND OPENINGS

- A. Provide formed openings where required for items to be embedded in passing through concrete work.
- B. Locate and set in place items which will be cast directly into concrete.
- C. Coordinate with work of other sections in forming and placing openings, slots, reglets, recesses, sleeves, bolts, anchors, other inserts, and components of other Work.
- D. Position recessed reglets for brick veneer masonry anchors to spacing and intervals noted on drawings or specified in Section 04200.
- E. Install accessories in accordance with manufacturer's instructions, straight, level, and plumb. Ensure items are not disturbed during concrete placement.
- F. Install waterstops in accordance with manufacturer's instruction continuous without displacing reinforcement.
- G. Provide temporary ports or openings in formwork where required to facilitate cleaning and inspection. Locate openings at bottom of forms to allow flushing water to drain.
- H. Close temporary openings with tight fitting panels, flush with inside face of forms, and neatly fitted so joints will not be apparent in exposed concrete surfaces.

3.6 FORM CLEANING

- A. Clean forms as erection proceeds, to remove foreign matter within forms.
- B. Clean formed cavities of debris prior to placing concrete.
- C. Flush with water or use compressed air to remove remaining foreign matter. Ensure that water and debris drain to exterior through clean—out ports.

- D. During cold weather, remove ice and snow from within forms. Do not use de-icing salts. Do not use water to clean out forms, unless formwork and concrete construction proceed within heated enclosure. Use compressed air or other means to remove foreign matter.

3.7 FORMWORK TOLERANCES

- A. Construct formwork to maintain tolerances required by ACI 301.

3.8 FIELD QUALITY CONTROL

- A. Inspect erected formwork, shoring, and bracing to ensure that work is in accordance with formwork design, and that supports, fastenings, wedges, ties, and items are secure.

3.9 FORM REMOVAL

- A. Do not remove forms or bracing until concrete has gained sufficient strength to carry its own weight and imposed loads.
- B. Loosen forms carefully. Do not wedge pry bars, hammers, or tools against finish concrete surfaces scheduled for exposure to view.
- C. Store removed forms in manner that surfaces to be in contact with fresh concrete will not be damaged. Discard damaged forms.

END OF SECTION

RELATED DOCUMENTS:

Drawings and general provisions of Contract, including General and Supplementary Conditions and Division-1 Specification sections, apply to work of this section.

PART 1: GENERAL

DESCRIPTION OF WORK:

Work of this Section shall include furnishing all labor and materials required to provide all cast-in-place concrete scheduled on Drawings and as specified in this Section.

Related Work Specified Elsewhere:

Concrete Formwork (Section 03100)
Concrete Reinforcement (Section 03300)

INDUSTRY STANDARDS:

For listing of names of industry standard agencies mentioned by abbreviation in this section refer to Industry Standards Index in Division 1.

LEED NC, U. S. Green Building Council

DELIVERY AND PROTECTION OF MATERIALS:

Store cement in weather tight structure with floor at least 12 inches off ground, and accessible for inspection in original packages.

Store fine and coarse aggregate separately. Segregate sizes and avoid getting dirt and foreign materials in concrete.

Deliver ready-mixed concrete in compliance with requirements set forth in ASTM C 94.

Provide documentation of LEED credits requirements for use of local regional materials.

SEVERE-WEATHER PROVISIONS:

Cold-Weather Concreting: (In accordance with ACI 306 and as follows):

Provide adequate equipment for heating concrete materials and protecting concrete during freezing or near-freezing weather. Do not use frozen materials, or materials containing ice.

All concrete materials and all reinforcement, forms, fillers, and around which concrete is in contact shall be free from frost.

Whenever temperature of surrounding air is below 40 degrees F., all concrete shall have temperature between 70 degrees and 80 degrees F. Provide adequate means for maintaining temperature not less than 70 degrees F. for three days, or 50 degrees F. for five days, or for as much more time as is necessary to insure curing of concrete.

Use no salt or other chemicals to prevent freezing.

Housing, covering, or other protection used in connection with curing shall remain in place, intact, at least 24 hours after artificial heat is discontinued.

Hot Weather Concreting: (In accordance with ACI 305 and as follows):

Provide adequate methods of lowering temperature of concrete ingredients so that temperature of concrete when placed does not exceed 90 degrees F.

When weather is such as to raise concrete temperature, as placed, consistently above 80 degrees F., use approved retarder.

Sprinkle all subgrade and forms with water before placing concrete. Remove all excess water before placing concrete.

Start curing as soon as practicable to prevent evaporation of water and keep forms wet. Protect flat work from dry wind, direct sun, and high temperatures.

PART 2: PRODUCTS

CEMENT:

Cement shall be standard portland cement of United States manufacture, conforming to ASTM C 150, Type I or Type III. Only one brand of commercial portland cement shall be used. Each bag shall weigh approximately 94 pounds and contain one cubic foot.

CONCRETE AGGREGATES:

Fine Aggregate: Washed sand having clean, hard, durable, uncoated grains, free from harmful substances conforming to ASTM C 33.

Coarse Aggregate for standard-weight concrete: crushed stone, gravel, or other approved inert material having clean, hard, durable uncoated particles conforming to ASTM C 33. Maximum size, in accordance with ACI 318.

Lightweight Coarse Aggregate shall conform to ASTM C 330. Lightweight aggregate shall be expanded shale or slate. Maximum size of aggregate shall be of 3/4".

WATER:

Clean and free from harmful amounts of acids, alkalis, or organic materials. No water shall be added at the site unless delivered, documented, and approved by the batch plant and testing agency.

VAPOR BARRIER:

Vapor barrier under floor slabs on earth shall be puncture resistant polyethylene sheet not less than 15 mils thick, with permeance of less than 0.01 perms per ASTM F 1249 or ASTM E 96, and in compliance with ASTM E 1745 Class A and ACI 302. Accessories would include seam tape and vapor proofing mastic with permeance less than 0.03 perms. Provide pipe boots constructed from vapor barrier material, pressure sensitive tape and/or mastic per manufacturer's instructions.

EXPANSION JOINT MATERIALS:

Expansion joint material shall be asphalt-impregnated fiber strips, 1/2" thick, unless otherwise shown or noted: Flexcell by Celotex Corporation, Sealtight by W. R. Meadows, Inc., Joint Filler by Serviced Products Corporation, or approved equal.

ADMIXTURES:

Water Reducing Admixture: ASTM C 494, Type A, and contain no chloride ions.

Air Entraining Admixture: ASTM C 60 for slabs permanently exposed to weather. No air entraining admixture is to be used for concrete not exposed to weather. Air content is to be confirmed by lab tests for both air entrained and non-air entrained mixes.

CLASS OF CONCRETE:

f'c minimum 4000 psi, maximum 150 pcf (regular weight) for exposed exterior concrete.

f'c minimum 3000 psi, maximum 150 pcf (regular weight).

f'c minimum 3000 psi, maximum 120 pcf (light weight-for use in elevated slabs).

f'c minimum 3000 psi, maximum 150 pcf (regular weight pea gravel) high slump mix for concrete masonry fill.

MIX DESIGNS:

Contractor shall select a testing laboratory acceptable to Architect to verify mixes of all classes of concrete.

Contractor shall submit samples in adequate quantities for each mix verification, of all concrete materials to be used on project to designated testing laboratory.

Laboratory shall be engaged by and paid by the contractor out of the material testing allowance.

Submit four (4) copies of all mix design, aggregate test results, and compression test results to Architect prior to use on the job.

PLANT MIXING:

Proportioning Concrete:

Stresses for design of this structure are based on specified minimum 28-day compressive strength of concrete. Proportions shall be in compliance with approved design mix for each class of concrete.

Batching:

Ready-mixed concrete shall be mixed and delivered in accordance with requirements of ASTM C 94.

Producer shall furnish delivery ticket with each load of concrete delivered under this Specification. Delivery ticket shall show clearly class and strength of concrete, size of coarse aggregate, slump ordered, and date and time of departure from batching plant.

1. Stresses for design of this structure are based on specified minimum 28-day compressive strength of concrete. Proportions shall be in compliance with approved design mix for each class of concrete.
2. Regular weight 3000 psi or 4000 psi concrete shall be proportioned for a slump of 4" + or - 1".
3. Lightweight 3000 psi concrete shall be proportioned for a slump of 6" + or - 1".

4. Fine aggregate 3000 psi concrete masonry grout shall be proportioned for a slump of 10" + or - 2".
5. All concrete shall be proportioned for a maximum water to cement ratio 0.5.
6. Concrete not permanently exposed to weather such as concrete for foundations, interior slabs on grade, concrete unit masonry grout, and elevated slabs on composite metal deck shall not have air added by entrainment admixtures. This requirement shall be verified by the testing laboratory.
7. Concrete to be permanently exposed to weather shall have air added by entrainment admixtures. Air content shall be 5% + or - 1%. This requirement shall be verified by the testing laboratory.

CONVEYING EQUIPMENT:

Carts or buggies transporting concrete more than 50 feet shall be equipped with pneumatic tires.

Equipment for chuting or conveying concrete shall be of sufficient size to insure continuous flow of concrete at delivery and without separation of materials.

PART 3: EXECUTION

EVALUATION OF COMPRESSION TESTS:

Evaluation of results of tests for ultimate-strength design concrete shall be according to ACI 318.

Neither results of laboratory verification tests nor any provision in Contract Documents shall relieve Contractor of obligation to furnish concrete of class and strength specified.

INSPECTION OF WORK BEFORE PLACING:

Inspect work to receive concrete for deficiencies which would prevent proper execution of finished work. Do not proceed with placing until such deficiencies are corrected.

Do not place concrete on earth until fill or excavation has been prepared as set forth under applicable sections of specifications for that work as verified by the testing lab.

Before any concrete is placed in form, all pipes or sleeves, openings, or embedded items shall be in place and shall receive all tests specified for them.

Remove all grease, oil, mud or other foreign matter from forms and have reinforcing steel in proper condition and position before placement of concrete. Dowels shall be in place and tied off prior to placing concrete.

Remove hardened, or partially hardened, concrete on forms or reinforcement before placing concrete.

CONVEYING:

Convey concrete from mixer to placement by methods which will prevent separation or loss of material. No water shall be added at the site to aid placement of concrete. Concrete too stiff to be properly placed shall be rejected and removed from the site and legally disposed of at no additional cost to the owner.

Runway supports shall not bear upon reinforcing steel or fresh concrete.

If pump(s) are used for conveying concrete, there shall be no aluminum in contact with the concrete, either in pump or in conveying pipes.

Clean conveying equipment thoroughly before run of concrete at frequent intervals.

CONSTRUCTION AND EXPANSION JOINTS:

Construction Joints: Early in construction program, contractor shall review with Architect construction joints he proposes to use, not indicated on the Drawings. Contractor shall not use any construction joints not approved by Architect.

Expansion Joints: Install as indicated.

PLACING:

Deposit concrete as nearly as practicable in its final position to avoid rehandling. Do not deposit concrete on work partially hardened or contaminated by foreign material. Do not use retempered concrete. In no case use concrete when elapsed time, after addition of water and cement to batch, exceeds one hour.

Concrete shall not be dropped more than four feet. For dropping greater distances use metal chutes or tremie pipes.

Once concreting is started carry on as continuous operation until placing of section is completed. Finish top surface to true plane. When construction joints are necessary, they shall be made in accordance with article above. Do not allow cold joints to occur within pours.

Compact all concrete thoroughly by suitable means during placing, and work thoroughly around reinforcement, embedded fixtures, and into corners of forms. When vibrator is used, apply directly to concrete. Do not over vibrate.

PROTECTION

During curing period protect concrete from damaging mechanical disturbances, particularly load stresses, heavy stock, and excessive vibration. Protect all finished concrete surfaces from damage by construction equipment, materials, or methods, and by rain, running water, hot sun, or windy conditions. Do not load self supporting structures in such a way as to overstress concrete.

Coordinate with protection requirements of Section 03362 – Polished Concrete Floor Finishes.

TESTING:

Conduct strength tests of concrete in accordance with following procedures:

Secure composite samples in accordance with "Method of Sampling Fresh Concrete" (ASTM C 172).

Mold and cure five specimens from each sample in accordance with "Method of Making and Curing Concrete Compression and Flexure Specimens in the Field" (ASTM C 31). Five specimen comprise one test.

Test Two Specimens at 7 days (ASTM C 39). Test two specimens at 28 days in accordance with "Method of Test for Compressive Strength of Molded Concrete Cylinders" (ASTM C 39). Test evaluation shall be conducted in accordance with provisions of ACI 318. Keep one Specimen in reserve.

Make one strength test for each 100 cu. yds. or fraction thereof for each mix design of concrete placed in any one day, except that in no case shall given mix design be represented by less than five tests.

Testing Laboratory shall be selected and paid by the Contractor out of the material testing allowance.

Report all test results to Architect, Structural Engineer, and Contractor on same day that tests are made.

Testing laboratory shall make and handle all test cylinders.

NON-CONFORMING MATERIAL

Any tested concrete material that fails to meet design strength at 28 days shall be removed and repoured. Substandard concrete may be allowed to remain if certified structurally adequate by a qualified independent engineer and approved by the Owner and Architect, however, the cost of the substandard material shall be deducted from the contract sum.

END OF SECTION

RELATED DOCUMENTS:

Drawings and general provisions of Contract, including General and Supplementary Conditions and Division-1 Specification sections, apply to work of this section.

PART 1: GENERAL

DESCRIPTION OF WORK:

Work shall consist of providing specified finishes to all cast-in-place concrete shown on drawings.

RELATED WORK:

Coordinate with requirements and work specified in Specification Section 03362 - Polished Concrete Floor Finishes.

INDUSTRY STANDARDS:

For listing of names of industry standard agencies mentioned by abbreviation in this Section refer to Industry Standards Index in Division 1.

SUBMITTALS:

Submit (in duplicate) Manufacturer's printed instructions for application of curing compounds and floor hardeners.

Coordinate with submittal requirements in Section 03362 – Polished Concrete Floor Finishes.

PART 2: PRODUCTS

FINE AGGREGATE: ASTM C 33, fine aggregate. Natural sand

PORTLAND CEMENT: ASTM C 150, Type 1, gray.

WATER:

Potable, and free of chemicals affecting set of cement.

CURING COMPOUND AND SEALER:

Transparent, resinous sealer, in volatile, conforming to ASTM C 309.

Coordinate with products specified in Section 03362 – Polished Concrete Floor Finishes.

LIQUID CHEMICAL FLOOR HARDENER:

Colorless, aqueous solution containing blend of magnesium fluosilicate and zinc fluosilicate with wetting agent, containing not less than 2 lbs. fluosilicates per gallon. Compound shall be approved by Architect in writing.

Coordinate with products specified in Section 03362 – Polished Concrete Floor Finishes.

ABRASIVE AGGREGATE:

Ceramically bonded aluminum oxide grains 1/8" to 1/32" size. Material shall be delivered to the site in the manufacturer's original container. Submit sample and manufacturer's descriptive data for approval.

JOINT SEALANTS:

Apply interior and exterior joint sealant products required by drawings at locations indicated on drawings.

PROTECTION:

Coordinate with protection requirements specified in Section 03362 – Polished Concrete Floor Finishes.

PART 3: EXECUTION

PATCHING CONCRETE:

Concrete which is not formed as shown on Drawings, or is out of alignment or level, or shows defective surface, or shows defects which reduce structural strength of member or members, shall be considered as not conforming to intent of these specifications and shall be removed from job by Contractor at his expense, unless Architect grants permission to patch effective area. Permission to patch any such area shall not be considered a waiver of Architect's right to require complete removal of defective work if patching does not, in his opinion, satisfactorily restore quality and appearance of surface, or if patching does not restore structural strength of member or members.

After removing forms, inspect all concrete surfaces. Patch any pour joints, voids, honeycomb, stone pockets, or other defective areas permitted by Architect to be patched, and all tie holes. Where necessary, chip away defective areas to depth of not less than 1", with edges perpendicular to surface. Wet area to be patched and space at least 6" wide entirely surrounding it to prevent absorption of water from patching mortar. Brush grout of equal parts portland cement and sand (with sufficient water to produce brushing consistency) into surface, followed immediately by patching mortar. Patching mortar shall be made of same material (and of approximately same proportions) as used for concrete except that coarse aggregate shall be omitted. Mortar shall not be richer than 1 part cement to 3 parts sand. Amount of mixing water shall be as little as is consistent with requirements of handling and placing. Mortar shall be retempered without addition of water by allowing it to stand for period of one hour, during which time it shall be mixed occasionally with trowel to prevent setting.

Compact mortar thoroughly into place and screed off to leave patch slightly higher than surrounding surface. Leave patch undisturbed for period of 1 to 2 hours to permit initial shrinkage before beginning final finishing. Finish patch in manner to match adjoining surface. On exposed surface where unlined forms have been used, obtain final finish by striking off surface with straight-edge spanning patch, held parallel to direction of form marks. All patches shall be used in accordance with curing requirements for surface in which patch occurs. Keep patch moist for not less than 3 days after installation.

Tie-holes left by withdrawal of rods, or holes, left by removal of ends of ties shall be filled solidly with mortar after first being wet thoroughly. Any excess mortar at surface of wall shall be struck off flush with cloth.

FLATNESS AND LEVELNESS:

Comply with ACI Standard No. 117 and provide floors with a flatness of F25 and a levelness of F20. Use laser guided equipment to set all forms. Use laser guided highway screed to achieve specified levelness and flatness. Use of BULLFLOATS is prohibited.

Areas of Integrally Colored and Dye Stained Polished Concrete Floor Finishes: Comply with ACI Standard No. 117 and provide floors with a flatness of minimum F50 and a minimum levelness of F30.

Use laser guided equipment to set all forms. Use laser guided highway screed to achieve specified levelness and flatness. Use of BULLFLOATS is prohibited.

TESTING:

Floors shall be tested for levelness and flatness by an independent testing agency, using a "Dipstick Floor Profiler". Floors that do not meet specification will be removed and re-constructed.

MONOLITHIC CEMENT FINISH:

Apply steel trowel finish to surface of concrete roof and floor slabs as follows:

- For all floors where, in Finish Schedule, resilient flooring or carpet covering is called for.
- For all roof slab areas (for future use as floor).
- For all other concrete floors, stairs, platforms, or slabs where, in Finish Schedule, or shown on Drawings, exposed concrete finish is called for, unless otherwise noted.

Screed floor slabs to an even surface by use of straight-edge and screeding strips accurately to proper grade. Float concrete with laser guided highway screed in manner which will compact and produce surface free from depressions or unevenness. Floors shall be level and flat within tolerances and guidelines specified, except where drains occur (in which cases floors shall be pitched to drains). Steel trowel concrete after concrete has hardened sufficiently to prevent fine materials from working to top, and only after all water sheen has disappeared. Drying of surface moisture before troweling shall proceed naturally, and shall not be hastened by dusting on of dry sand or cement. Perform final troweling after concrete has hardened so that no mortar accumulates on trowel and ringing sound is produced as trowel is drawn over surface.

Coordinate with requirements and work specified in Specification Section 03362 - Polished Concrete Floor Finishes.

Exterior Concreted Areas:

Provide all (walks and vertical surfaces) surfaces with a unidirectional fine broom finish, with concrete walk 1/2" tooled expansion joints at 30' centers maximum and sawcut joints at 5' centers maximum. Pour sample for Architect approval.

CURING:

General Requirements for Curing:

Prevent surfaces of concrete from drying out until required curing time has elapsed. Start curing procedures immediately following initial set of concrete.

Surfaces to Receive Finishes Set in Portland Cement Setting Beds:

Cover with non-staining, reinforced kraft paper. Lap kraft paper, and keep weighted down to prevent evaporation. Do not use membrane curing compound on these surfaces.

FLOOR HARDENER:

Apply to floor surfaces to be exposed in accordance with Manufacturer's printed instructions, and at a rate of not less than 100 sq. ft. per gallon. Apply uniform coating to avoid mottled appearance.

GLOSS URETHANE FLOOR SEALER FOR EQUIPMENT PLATFORMS, BOILER ROOMS, MECHANICAL ROOMS, ELECTRICAL ROOMS, CUSTODIAL ROOMS: (Apply whether scheduled or not; typical)

After all areas are final cleaned, to include removal of all stains and exposed reinforcing fibers, apply Rexthane clear gloss urethane to floor surfaces to be exposed (no floor finishes except sealer) in accordance with Manufacturer's printed instructions, and at a rate of not less than manufacture's application rate instructions and to achieve a permanent high gloss sheen. Apply uniform coating to avoid mottled appearance. Coordinate with Section 09900 requirements.

END OF SECTION

RELATED DOCUMENTS:

Drawings and general provisions of Contract, including General and Supplementary Conditions and Division-1 Specification sections, apply to work of this section.

PART 1: GENERAL

1.1 SECTION INCLUDES

- A. Reinforcing steel bars, wire fabric and accessories for cast-in-place concrete.

1.2 REFERENCES

- A. ACI 301 - Structural Concrete for Buildings.
- B. ACI 318 - Building Code Requirements For Reinforced Concrete.
- C. ACI SP-66 - American Concrete Institute - Detailing Manual.
- D. ANSI/ASTM A82 - Cold Drawn Steel Wire for Concrete Reinforcement.
- E. ANSI/ASTM A184 - Fabricated Deformed Steel Bar Mats for Concrete Reinforcement.
- F. ANSI/ASTM A185 - Welded Steel Wire Fabric for Concrete Reinforcement.
- G. ANSI/ASTM A496 - Deformed Steel Wire Fabric for Concrete Reinforcement.
- H. ANSI/ASTM A497 - Welded Deformed Steel Wire Fabric for Concrete Reinforcement.
- I. ANSI/AWS D1.4 - Structural Welding Code for Reinforcing Steel.
- J. ASTM A615 - Deformed and Plain Billet Steel Bars for Concrete Reinforcement.
- K. ASTM A616 - Rail Steel Deformed and Plain Bars for Concrete Reinforcement.
- L. ASTM A617 - Axle Steel Deformed and Plain Bars for Concrete Reinforcement.
- M. ASTM A704 - Welded Steel Plain Bar or Rod Mats for Concrete Reinforcement.
- N. ASTM A706 - Low-Alloy Steel Deformed Bars for Concrete Reinforcement.
- O. ASTM A767 - Zinc-Coated (Galvanized) Bars for Concrete Reinforcement.
- P. ASTM A775 - Epoxy-Coated Reinforcing Steel Bars.
- Q. ASTM D3963 - Epoxy-Coated Reinforcing Steel.
- R. ASTM C1116 – Standard Specification for Fiber-Reinforced Concrete and Shotcrete
- S. AWS D12.1 - Welding Reinforcement Steel, Metal Inserts and Connections in Reinforced Concrete Construction.
- T. CRSI - Concrete Reinforcing Steel Institute - Manual of Practice.
- U. CRSI 63 - Recommended Practice For Placing Reinforcing Bars.

- V. CRSI 65 - Recommended Practice For Placing Bar Supports, Specifications and Nomenclature.

1.3 SUBMITTALS

- A. Shop Drawings: Indicate bar sizes, spacings, locations, and quantities of reinforcing steel and wire fabric, bending and cutting schedules, and supporting and spacing devices.
- B. Manufacturer's Certificate: Certify that products meet or exceed specified requirements.
- C. Submit in writing any request for deviation from the design drawings and specifications.

1.4 QUALITY ASSURANCE

- A. Perform Work in accordance with CRSI 63, 65 and Manual of Practice, ACI 301, ACI SP-66, ACI 318, ANSI/ASTM A184.
- B. Submit certified copies of mill test report of reinforcement materials analysis.

1.5 COORDINATION

- A. Coordinate with placement of formwork, formed openings and other Work.

PART 2: PRODUCTS

2.1 REINFORCEMENT

- A. Reinforcing Steel: ASTM A615, 60 ksi yield grade; deformed billet steel bars, unfinished.
- B. Welded Steel Wire Fabric: ASTM A185 Plain Type; in flat sheets; unfinished. Rolled WWF shall not be acceptable for use on this job.

2.2 ACCESSORY MATERIALS

- A. Tie Wire: Minimum 16 gage annealed type.
- B. Chairs, Bolsters, Bar Supports, Spacers: Sized and shaped for strength and support of reinforcement during concrete placement conditions including load bearing pad on bottom to prevent vapor barrier puncture.
- C. Special Chairs, Bolsters, Bar Supports, Spacers Adjacent to Weather Exposed Concrete Surfaces: Stainless steel type; size and shape as required.

2.3 FABRICATION

- A. Fabricate concrete reinforcing in accordance with CRSI Manual of Practice ACI SP-66, ACI 318 ANSI/ASTM A184.
- B. Locate reinforcing splices not indicated on drawings, at point of minimum stress. Indicate location of splices on shop drawings for approval by the Architect/Engineer.

PART 3: EXECUTION

3.1 HANDLING AND STORAGE

- A. Provide proper equipment for safe off loading and handling of material.
- B. Provide proper clean level storage area with proper skids to keep material clear of mud and water.
- C. Keep material free from mud and other deleterious materials that will reduce bond and do not place any reinforcing bars that are bent, twisted, broken, pitted, or otherwise unsuitable for use on the project as determined by the architect.
- D. All necessary field bending and straightening shall be accomplished without heating the material.
- E. Cutting torch shall be used only for cut off of material but not for bending. All heat bent material will be rejected by the inspector and shall be promptly removed and replaced at no additional cost. Do not weld reinforcing bars.

3.2 PLACEMENT

- A. Place, support and secure reinforcement against displacement. Do not deviate from required position. WWF laying on the metal deck and being manually pulled up into the fresh concrete during concrete placement operations shall not be acceptable.
- B. Do not displace or damage vapor barriers. Damaged vapor barrier shall be removed and replaced at the direction of the Architect.
- C. Accommodate placement of formed openings.
- D. Maintain concrete cover around reinforcing as indicated on drawings.
- E. Provide proper and adequate supports at maximum 3 ft x 3 ft spacing each way for support of wwf in the designated position. Tie off wwf sheets so that placement of the fresh concrete will not cause the wwf to be displaced. Pulling up of the wwf sheets into freshly placed concrete will not be an acceptable means of placing the wwf.

3.3 FIELD QUALITY CONTROL

- A. Field inspection will be performed by the Architect.

END OF SECTION

RELATED DOCUMENTS:

The general provisions of the Contract, including General and Supplementary Conditions, and General Requirements, and Division 1 specifications that apply to the work specified in this Section.

PART 1 GENERAL:

1.01 DESCRIPTION OF WORK:

- A. Furnish And Install All Architectural Precast Concrete Units (White).
- B. Related Work Specified Elsewhere
 - a. Division 3 Specifications

1.02 APPLICABLE PUBLICATIONS: The publications listed below form a part of this specification to the extent referenced. The publications are referred to in the text by the basic designation only.

- A. American Concrete Institute (ACI) Publications:
 - 1. 211.1-81 Standard practice for selecting proportions for concrete.
 - 2. 214-77 (R83) Recommended practice for evaluation of strength test results of concrete.
 - 3. 301-84 Specifications for structural concrete for buildings.
 - 4. 304-73 Recommended practice for measuring, mixing, transporting, and placing concrete.
 - 5. 305r-82 Hot weather concreting.
 - 6. 306r-78 Cold weather concreting.
- B. American Society for Testing Materials (ASTM) Publications:
 - 1. A 36-81a Structural steel.
 - 2. A 185-79 Welded steel wire fabric for concrete reinforcement.
 - 3. A 283-81 Low and intermediate tensile strength carbon steel plates, shapes, and bars.
 - 4. A 615-82 Deformed and plain billet-steel bars for concrete reinforcement.
 - 5. C 31-84 Making and curing concrete test specimens in the field.
 - 6. C 33-84 Concrete aggregates.
 - 7. C 39-83b Compressive strength of cylindrical concrete specimens.
 - 8. C 94 Concrete batch plant, mixer, mixing and measuring.
 - 9. C 150-84 Portland cement.
- C. Prestressed Concrete Institute (PCI) and Architectural Precast Association (APA) Publications:
 - 1. MNL 117-77 Manual for quality control for plants and production of Architectural Precast Concrete products.
 - 2. 2nd edition Architectural Precast Concrete

1.03. SUBMITTALS:

- A. Shop drawings and descriptive data: Before manufacture of A.P.C. units, submit and obtain approval for shop drawings and descriptive data including the following:
 - 1. Layout, dimensions, cross sections, and edge details, location and type of reinforcement including reinforcement for safe handling.
 - 2. Design calculations showing compliance with indicated loading conditions.
 - 3. Setting drawings for A.P.C. units and anchors.
- B. Manufacturer's Mix Design:

1. Submit a mix design for the Architectural Precast Concrete including a complete list of materials with brand names and sources.
 2. Provide test reports indicating that mix has been tested to meet properties specified.
 3. Obtain approval before proceeding with manufacture.
- C. Catalog Data:
1. Architectural Precast Concrete producer's literature and company information.
 2. Plant certification information
 3. Anchorage information.
 4. Joint sealant information
- D. Samples: Samples to be submitted as follows:
1. Submit Architectural Precast Concrete samples to illustrate quality, color and finish.
 2. Smooth form finish
 3. Colors to match available standard colors of Seaboard Concrete Products Company
- 1.04.1 **DELIVERY AND STORAGE:**
- A. Deliver Architectural Precast Concrete units on supports designed for the protection of these units, or packed and wrapped on pallets for job site storage.

PART 2 PRODUCTS

2.01 CONCRETE:

- A. Manufacturer's Mix Design:
 1. Concrete shall have a 28 day compressive strength of 5,000 PSI and a 4 to 6 percent of water absorption.
- B. Concrete Mix Materials:
 1. Provide aggregates, sand, mineral pigments, Admixtures and White Portland Cement to produce concrete with the specified properties and capable of obtaining the approved color and smooth form finish.
- C. Backing Mix:
 1. Back up mix not allowed, cast units solidly with one concrete mix.

2.02 MATERIALS:

- A. Aggregates:
 1. Aggregates shall be natural white stone particles to match the smooth - acid etched finish sample on file.
- B. Cement:
 1. White Portland Cement,
 2. ASTM C 150-84,
 3. Type I or II
- C. Admixtures:
 1. ASTM C 494.
 2. Calcium chloride shall not be used.
- D. Water: Potable
- E. Reinforcement:
 1. Reinforcement bars:
 - a. ACI 301.

- b. Galvanized after fabrication.
 - 2. Welded wire fabric:
 - a. ASTM A 185 OR ASTM A 497. Galvanized.
 - F. Threaded type concrete inserts:
 - 1. ASTM A 47 OR ASTM A 27. Plated or Galvanized.
 - G. Weld plate anchors:
 - 1. ASTM A 36 Steel. shop painted.
 - H. Flashing reglets:
 - 1. Galvanized sheet metal.
 - I.. Clip angles:
 - 1. ASTM A 36 Steel. Shop painted.
 - J. Dowels:
 - 1. ASTM A 36 Steel. Galvanized.

2.03 **UNIT FABRICATION:**

- A. Formwork and fabrication tolerances:
 - 1. Provide metal, concrete, wood or rubber forms, designed and built to resist deformation.
 - 2. Provide dimensional tolerances as follows:
 - a. Overall unit dimensions - plus/minus 1/8 inch.
 - b. Cross sectional dimension – plus/minus 3/16 inch.
 - c. Deviation from square – not to exceed 1/8 inch.
 - d. Anchor location – plus/minus 1 inch.
- B. Reinforcement:
 - 1. ACI 301. Properly place, locate, and secure reinforcing bars and welded wire mesh.
- C. Concrete mixing and measurement:
 - 1. ASTM C 94.
- D. Concrete placement:
 - 1. ACI 303 AND MNL 117-77.
 - 2. Deposit concrete continuously into forms to prevent formation of planes of weakness in units.
 - 3. Place concrete within a temperature range between 50 and 90 degrees f.
 - 4. Consolidate concrete to prevent segregation and to produce a dense concrete, free of honey combs.
 - 5. Units shall be made by the “wet pour” process.
 - 6. The “dry tamp” method will not be accepted.
- E. Identification markings:
 - 1. Mark each unit to correlate with approved shop/setting drawings.
 - 2. Do not locate markings on finished surfaces.
- F. Exposed to view finished surfaces:
 - 1. Smooth - acid etched finish on all finished faces.
- G. Concealed surfaces:
 - 1. Provide a form or troweled surface.
- H. Curing:

1. Maintain units in a damp environment until concrete attained 60% of design strength.
- I. Manufacturer:
 1. Producer to be Cast Stone Systems, Inc. or an approved equal fabricator.
 2. Manufacturing facility is to be a "certified plant" under the Certification programs of the Architectural Precast Association (APA) or the Prestressed Concrete Institute (PCI).

PART 3 – EXECUTION

3.01 **Installation:** Install Architectural Precast Concrete units in accordance with approved shop drawings and descriptive data, and as specified below:

- A. Building framing system:
 1. Allow for adjustment to compensate for sagging in the structural steel members as the architectural precast concrete units are erected.
- B. Placing units:
 1. Provide temporary supports and bracing as required to maintain unit position and alignment during attachment to the building.
 2. Properly weld/bolt all connections after units are positioned.
- C. Erection tolerances:
 1. Locate units to accommodate adjacent materials, proper joint width, and alignment with adjacent.
 2. Units dimensional tolerances are:
 - a. Joint width - +/- 3/16 inch
 - b. Unit alignment- +/- 1/4 inch
- D. Joints:
 1. Joints shall utilize Type S Mortar mix, with compressive strength of 1800 psi minimum, in compliance with ASTM C-270, and matching the APC color.
 2. Control joints (located in alignment with adjacent wall control joints) shall be sealants specified under section 07920 Sealants, matching the APC color.
- E. Protection:
 1. Protect exposed surfaces from staining and construction damage.
 2. Extra care shall be taken to avoid damage and staining from tar used in the roofing operation.
- F. Cleaning:
 1. Thoroughly clean all Architectural Precast Concrete units after installation.
 2. Use detergent, SUR-clean, and ample water, using a brush to scrub clean.
- G. Sealing:
 1. Seal with liquid sealer products per manufacturer's directions as specified in 09900 Paint.

PART 4 – QUALITY CONTROL:

4.01 **Product Quality:**

- A. Provide a quality control program as mandated under the Plant certification programs of either the APA or PCI.
- B. Rejection: Units may be rejected for the following deficiencies:

1. Nonconformance to specified tolerances,
2. Damage incurred during construction,
3. Ragged or irregular edges,
4. Honeycombs/voids on finished surfaces,
5. Excessive variation in color or finish from approved sample,
or unit to unit,
6. Form lines or irregular surfaces,
7. Visible repairs or cracks,
8. Surface crazing.
9. Defective sealer coat
10. Unacceptable workmanship

END OF SECTION

RELATED DOCUMENTS:

Drawings and general provisions of Contract, including General and Supplementary Conditions and Division-1 Specification sections, apply to work of this section.

PART 1: GENERAL

DESCRIPTION:

Work Included: The work required under this Section includes furnishing all labor, equipment, materials, and services necessary to complete the brick and masonry block work indicated on the Drawings, or specified herein.

QUALITY ASSURANCE:

Qualifications of Workmen: The masonry work shall be accomplished by experienced masons under the direct supervision of a journey man mason.

Codes and Standards: In addition to complying with all pertinent codes and regulations, material and workmanship shall comply with standards of the National Concrete Masonry Association and the Structural Clay Products Institute.

SUBMITTALS:

Samples: Within thirty (30) days after award of Contract, and before any brick or unit masonry materials are delivered to the job site, submit samples as required of the proposed brick and concrete masonry units to the Architect for his approval.

Certification: Prior to delivery of concrete unit masonry to the job site, deliver to the Architect a letter from the manufacturer of the concrete masonry units certifying that all such concrete masonry units delivered to the job site are in strict conformance with the provisions of this Section of these Specifications.

Sample Panels: Before the masonry work is started, approved sample panels approximately 5 feet long by 4 feet high and of the proper thickness shall be constructed at the job site, reviewed and approved by the Architect. One face shall show the workmanship, coursing, bond, mortar joint thickness, tooling of joints, and range of brick color and texture, all to be as specified or selected by the Architect/Engineer.

Sample panel shall duplicate the wall assembly construction with the thru-wall flashing system. The finished work shall match the approved sample panel. Mock up to be maintained throughout construction for workmanship quality control reference.

PRODUCT HANDLING:

Protection: Use all means necessary to protect brick and concrete masonry materials before, during, and after installation and to protect the installed work and materials of all other trades. Cover masonry blocks and brick to prevent excessive moisture absorption.

Portland Cement, lime, and/or pre-packaged mortar mixes shall be delivered to the site and stored in unbroken bags or other approved containers. These materials shall be stored in dry, weather tight sheds or enclosures with elevated floors, which will prevent the inclusion of foreign materials and damage by water or dampness. Masonry sand shall be delivered and stored in a manner to prevent inclusion of foreign material. Brick shall be delivered and stored on the job site on platforms or timbers, clear of the ground. Brick which are chipped, cracked, broken, or marred in other manner shall not be used where exposed to view.

PART 2: PRODUCTS

CONCRETE MASONRY UNITS:

General: All concrete masonry units shall be of sizes shown on Drawings, two-cell type, in gray or neutral color, and conforming with ASTM C-90 Standard Specification for Load Bearing Concrete Masonry Units. Provide all special shapes required or indicated, including 45-degree angled units. Provide units with bullnosed exterior corners at all exposed areas.

Standard Grey CMU:

Size: As indicated in the drawings

Color: Standard Color and Texture.

Minimum Net Area Average Compressive Strength: Average of three units 2000 PSI, no individual unit less than 1800 PSI.

Maximum Absorption: Absorption is less than 18 lbs/CF.

Weight Classification: Units shall be lightweight, blended with expanded shale, clay or slate, produced by the rotary kiln process and shall comply with ASTM C331 and ASTM C33 and shall be graded to assure consistent texture.

All units shall be free of organic impurities that will cause rusting, staining, or pop outs and shall contain no combustible material. All lightweight material to be manufactured by rotary kiln process. The use of coal burning power plants residue aggregate (bottom ash) or similar waste products will not be allowed.

The producer of the lightweight concrete masonry units shall furnish a letter of certification stating that all lightweight aggregate used in the manufacturer of the units was expanded shale, clay or slate produced by the rotary kiln process, Big River industries or approved equal conforming to ASTM C331 and ASTM C33.

Acceptable Manufacturers:

Adams Products Company - Oldcastle, Johnson Concrete Company or approved equal. Manufacturer other than approved listed shall provide submittal samples and received written approval by the Architect prior to bid.

BRICK:

Common brick to be modular size, nominal 2 1/4" x 4" x 8", and shall conform to ASTM C-62, grade MW, for use below grade and where not exposed.

Face brick shall be through body wire-cut, modular size nominal 2 1/4" x 4" x 8", and conform to ASTM C-69, grade SW, use for all exposed brick, unless otherwise noted. Provide all brick types, sizes, shapes, colors, special shapes, tax, delivery freight, and Contractor discounts and rebates, purchased with a brick allowance of \$800 per thousand brick.

MORTAR:

General: Cementitious materials and aggregates shall be handled and stored in such a manner as to prevent deterioration or intrusion of foreign materials. Each material shall be of like brand; all sand shall be supplied from a single source; sand color to be approved by Architect.

Cement: Shall be Portland Cement, Type I or II, meeting Standard Specifications for Portland Cement (ASTM C-150).

Sand: Shall be clean, washed, and meet the requirements of Standard Specification for Aggregate or Masonry Mortar (ASTM C-144-76), with the gradation to satisfy paragraph 3, Grading, and with the omission of subparagraph 3.4.

Hydrated Lime: Shall meet the requirements of the Standard Specification for Hydrated Lime for Masonry Purposes (ASTM C-207), Type S.

Hydraulic Hydrated Lime: Shall meet the requirements of the Standard Specification for Hydraulic Hydrated Lime for Structural Purposes (ASTM C-141).

Color: Mortar shall be natural grey.

Water: Shall be potable.

Admixture-workability and air entraining admixtures may be utilized and shall conform to ASTM C-260.

Portland Cement: ASTM C-10, or Fed. Spec. SS-C-192, Type I, II, or III.

Aggregates: ASTM C-144, aggregate for masonry mortar.

Water: Shall be clean and free of deleterious amounts of acids, alkalies, or organic materials.

Plasticizing Agent: Shall be OMICRON by Master Builders, "Hydrocide Powder", by Sonneborn Bldg. Products, Inc., Subsidiary of DeSoto, Inc., "Hydrolox 400" by Chem-Masters Corp., or approved equal, and used in accordance with mfgs. instructions.

Anti-Freeze Compounds: No anti-freeze liquid, salt, accelerating admixture for masonry mortar or other substance shall be in the mortar to lower the freezing point of the mixing water or accelerate the set of the cement.

Prepackaged Mortar Mixes: Prepackaged mortar mixes may be used with the prior approval of the Architect. The mortar mix shall be in accordance with the following specifications.

Type S Mortar Mix: The mortar mix shall have a compressive strength of 1800 psi minimum at 28 days when tested in accordance with ASTM C-270.

The mortar mix shall contain Portland Cement, hydrated lime, plasticizing admixtures, and/or hydraulic hydrated lime. Mortar mixes which contain other materials, including ground limestone ground slag or other cementitious and non-cementitious materials, are not acceptable.

Bag Label: Each bag of mortar mix shall have a printed label thereon which shall show the contents. Contents shall be described by the percent by volume of Portland Cement (ASTM C-150).

Hydrated Lime (ASTM C-207), Hydraulic Hydrated Lime (ASTM C-141), and Admixtures (ASTM C-260).

Instructions for mixing the mortar mix shall be clearly printed on the container. These instructions shall be by volumetric measurement and shall be limited to the method of mixing in proper proportions of washed sand to 1 bag of the prepackaged mortar mix with water to produce a flow of the proper consistency.

The mortar mix shall be composed only of Portland Cement, Hydrated lime and/or Hydraulic Hydrated Lime and workability admixtures within the following limits:

- a. Maximum of 65% Portland Cement.
- b. Minimum of 33% Hydrated Lime and/or Hydraulic Hydrated Lime.
- c. Maximum of 2% Admixtures.

Air Content: The air content of the pre-packaged mortar mix shall be limited to 16% maximum when tested in accordance with ASTM C-91, Paragraphs 18 through 22.

Autoclave Expansion: Autoclave expansion of the mortar mix shall not exceed 1.0% when determined in accordance with ASTM Method C-151.

On-The-Job Mortar Mix:

Type S. Mortar shall have a compressive strength of 1800 psi minimum at 28 days. The mortar shall be proportioned within the following volumetric limits:

- a. 1 part Portland Cement
- b. 1/2 part Hydrated Lime
- c. Not less than 2 1/4 and not more than 3 times the sum of the volumes of cement and lime used of washed sand measured in a damp, loose condition.
- d. Plasticized per instructions of the mfr., the quantity of which is not to exceed 2% by volume of the cement and lime combination.

Measurement and Mixing:

The method of measuring materials shall be by volume and shall be such that the specified proportions of the mortar materials can be controlled and accurately maintained. A measuring device to make consistent volume measurements shall be used throughout the project. Measurement of washed sand by shovel shall not be permitted.

Mortar Mixer shall be a paddle-type mechanical mixer. It shall be of such design and size to accommodate the mix without overloading, and be adequately powered to vigorously mix the ingredients.

The mortar mixer shall be charged in this order: Add approximately one-half the water required, one-half the washed sand, the cement and lime or prepackaged mortar mix), the remaining amount of washed sand, and then sufficient water to bring the mix to desired consistency. Mortar shall be mixed for a minimum of five minutes after all materials have been charged into the mixer with all batches being mixed to the same consistency.

Mortars that have stiffened because of evaporation of water from the mortar may be retempered by adding water as frequently as needed to restore the required consistency. Mortars shall be used and placed in their final position within 2 hours after mixing. When the temperature is over 80 degrees F., the mortar shall be used within 1 1/2 hours after mixing. Mortar not used within these time periods shall be discarded.

HORIZONTAL JOINT REINFORCEMENT STEEL:

Standards: All components shall be hot-dip galvanized to ASTM A 153 after fabrication.

Joint Reinforcement for CMU/Brick Veneer Cavity Wall: Truss type in CMU backup wall with hook and key eye; steel wire, hot dip galvanized to ASTM A 153 after fabrication, cold drawn steel wire conforming

to ASTM A82, 3/16 inch side rods with No.9 diagonal ties. Backup wall reinforcing shall be units no more than two (2) inches smaller in width than the wall thickness and shall be of deformed rods 3/16" side rods and 9 gage diagonal cross rods all galvanized. Veneer anchored with 3/16" keys and hooks, keys are 4-point flush-welded to backup wall rods. Total unit width shall be no more than two (2) inches smaller in width than the total wall thickness. Hooks shall be extended into veneer wythe 1" from exterior face. Provide Hohmann & Barnard LOX-ALL Adjusto-Flex-Mesh #AF-H Truss, Wire-Bond Series 700 adjustable tab, Dur-O-Eye by Dayton Superior or approved equivalent products.

Interior CMU wall reinforcing shall be Truss Type, as mfgd. by AA Wire Products Co., "DUR-O-WALL", Hohmann & Barnard "LOX-ALL", or other approved equal products. Provide prefabricated corners and intersections. Manufactured in accordance with Uniform Building Code Standard UBC 21-10, ASTM A951, ASTM A580 – Type 304, ACI 530/ASCE 5/TMS402 Building Code Requirements for Masonry Structures.

Reinforcing shall be units no more than two (2) inches smaller in width than the wall thickness and shall be of deformed rods 3/16" side rods and 9 gage diagonal cross rods all galvanized.

Provide prefabricated Tees and Corners at all wall intersections.

Interior block partitions shall be reinforced similar to exterior walls.

Spacing: Reinforcing for exterior and interior walls shall be 16" o.c. vertically beginning at the finish floor line and provide line of reinforcing one block course and one below all window heads and sills. Extend 16" beyond jambs on each side.

Lap all splices one full panel of reinforcing unit.

WALL TIES TO STRUCTURAL STEEL:

All exterior and interior masonry walls shall be tied to contiguous steel columns and beams with two-piece adjustable tie units such as, Hohmann and Barnard 359 Weld-On Ties; ¼" diameter x 8" long hot dip-galvanized bent wire, or equivalent column and beam anchors by Wire-Bond or Heckman, with Hohmann and Barnard VBT-Vee Byna-Tie 3/16" diameter hot-dip galvanized triangular wire ties or approved equal by Wire-Bond or Heckman.

Space wall ties to columns and beams at 16" o.c. maximum. Tie anchors shall be welded to structural steel with 4 fillet welds 1/8" x 3/4".

WALL TIES TO LIGHT GAGE METAL WALL STUDS

All exterior masonry veneer with metal stud back up shall be tied to metal studs with two piece adjustable tie units such as Heckman 12 gage 315-D, Hohmann and Barnard 12 gage DW-10HS, or 12 gage Wire-Bond Type III anchors with 3/16 diameter triangular wire ties or approved equal.

Space wall ties so that no tie is required to tie more than 2 2/3 square feet of masonry veneer or 24" oc maximum. Tie anchors shall be attached to metal studs with 2 - #12 self drilling self tapping screws.

FLASHING SYSTEM:

Thru-Wall Flashing system: 40 mil thick EPDM rubber membrane, containing no asphalt, equivalent to Sandell EPDM Rubber Thru-wall Flashing with Carlisle SecurTape splicing tape, and continuous pre-formed stainless steel drip edge. Install in compliance manufacturer's instructions.

Thru-wall flashing shall be completely secured into masonry joints or surface fully adhered throughout all wall assemblies, with all lap joints 100% sealed, in a complete continuous waterproof installation. Provide

all necessary accessory components for a complete assembly; to include required roll-on primers, spray adhesives, pressure sensitive adhesive tape, termination bars, etc. wherever necessary.

Locations: Wall flashing system shall be installed over all masonry opening heads and sills, over all lintels in exterior walls, at all weephole locations, continuous around columns, and elsewhere indicated on Drawings.

Build a mock-up installation into the masonry sample panel for review and approval by Architect.

Required Thru-Wall Flashing Accessories:

Carlisle SecurTape Splicing Tape: 3" wide x 100' long roll, double-sided, synthetic cured rubber EPDM adhesive tape, .030" thick. Features a clear poly release film. Apply to cleaned EPDM flashing lap seams and adhere tightly with roller. Primers and spray adhesives shall be applied to surfaces to receive adhesive tape.

Sando-Seal lap sealant: Apply to all exposed edges at surface applied conditions, eliminating any voids, pockets or depressions where moisture would accumulate.

Sandell's S-600 Primer: Manufacturer's special primer formulated to prepare surfaces for adhering flashing to surfaces with pressure sensitive adhesive tape.

Sandell's Self-Adhering End Dams: preformed rubberized asphalt with adhesive surface and release layer film. Install above and beneath all wall openings, all longitudinal ends of flashing, lintel ends, at column abutments, near building expansion joints, and all cavity wall conditions whenever flashing interruptions occur.

Sandell's Self-Adhering Corners: preformed rubberized asphalt with adhesive surface and release layer film. Install at exterior and interior corner conditions. Flashing membrane shall overlap preformed corners, adhere and form a continuous waterproof seal.

Pre-Formed Stainless Steel Drip Edge: Provide a continuous pre-formed stainless steel drip edge at all flashings. 28 gauge, dull finish Type 304 stainless steel, ASTM A-167. Minimum 1 5/8" wide with a 3/8" bent safety drip edge. Flashing membrane shall lap and adhere onto drip edge for a continuous waterproof assembly. Flashing membrane shall be terminated at 1/2" from face of finished wall surface.

Weeps: Plastic weep inserts shall be Cell Vent Weep-Hole Ventilator by DUR-O-WALL or equivalent. 3/8" thick x full head joint height equivalent to actual brick size height, color clear. Install at all wall flashing locations with weepholes indicated on Drawings.

PART 3: EXECUTION

SURFACE CONDITIONS:

Inspection:

Prior to all work of this Section, carefully inspect the installed work of all other trades and verify that all such work is complete to the point where this installation may properly commence.

Verify that concrete unit masonry may be completed in accordance with all pertinent codes and regulations, referenced standards, and the original design.

Discrepancies: In the event of discrepancy, immediately notify the Architect. Do not proceed with installation in areas of discrepancy until all such discrepancies have been completely resolved.

COORDINATION:

Carefully coordinate with all other trades to insure proper and adequate interface of the work of other trades with the work of this Section.

INSTALLATION OF MASONRY:

GENERAL: Lay up all walls in running bond, plumb, level, and true to the lines and dimensions indicated on the Drawings. Maintain uniform head and bed joint of 3/8" vertically and horizontally. Masonry Contractor shall use sled runner jointing tool wherever possible to maintain consistency.

Do not use chipped or broken units. If any such units are discovered in the finished wall, the Architect may require their immediate removal and replacement with new units at no additional cost to the Owner.

Bullnose CMU shall be begin at floor line, with first unit above floor at a bullnose corner being a bullnose unit, not a square corner unit.

Wetting of Brick: All brick shall be thoroughly wetted as necessary to reduce the rate of absorption of water a time of laying to not more than 0.7 of an ounce (20 grams per minute) per brick when placed on its flat side in 1/4" of water for one minute.

Brick Laying Technique:

All joints between brick shall be completely filled with mortar. Brick shall be laid in a full, lightly furrowed bed of mortar with the head joints completely filled by placing sufficient mortar on the end of the brick so that when the brick is shoved into place, the head joint will be filled. Buttering of face edge and then slushing will not be permitted. All joints, both interior and exterior shall be cut flush.

Disturbed Units: Where brick are disturbed or must be moved after the mortar has begun to lose its moisture, the brick and all adjacent mortar shall be removed and reset completely.

Tooling: Exterior and Interior brick joints shall be tooled to a uniform concave joint (unless otherwise noted) using a metal tool designed for that purpose, head joints first and then the bed joints. Interior CMU joints shall be tooled to a uniform concave joint. All joints shall be tooled at approximately the same degree of moisture content and firmness to achieve a uniform color and texture.

Where indicated provide raked tooled joints.

POINTING OF MASONRY:

At the completion of the masonry work, all holes in the exposed masonry shall be pointed. Defective joints shall be cut out and tuckpointed solidly with mortar. Pointing and tuckpointing shall be done with a pre-hydrated mortar. The mortar mix shall be controlled so that after curing of the mortar, no difference in texture or color exists with that of adjacent masonry. Where indicated, provide tuckpointing of existing masonry.

COLD WEATHER:

No bricklaying shall be performed unless the temperature of the surrounding air is 40 degrees F. and rising. The use of "anti-freeze" or accelerating admixtures is not permitted. Provide temporary protection of completed portions of masonry to insure a minimum 48 hours curing at a minimum 40 degrees F.

MASONRY OPENINGS:

The General Contractor and/or his masonry subcontractor shall be responsible for coordinating and building into all walls, the required openings necessary to permit the passage of duct work and piping by the mechanical contractors. These required openings shall be located and constructed as the work progresses. Knocking out large openings after work has been constructed will not be permitted. Structural lintels shall be furnished and installed by the General Contractor.

MASONRY CLEANING:

While laying the brick, good workmanship and job housekeeping practices shall be used so as to minimize the need for cleaning the brick. Protect the base of the wall from mud splashes and mortar droppings, protect the wall by setting scaffolds so that mortar is not deflected onto the wall, and at the end of each work day set the scaffolding boards so that they do not deflect rainfall onto newly laid masonry.

The bricklaying technique shall be such that mortar does not run down the face of the wall, or smear the mortar onto the brick face.

After the joints are tooled, cut off mortar tailings with the trowel and brush excess mortar burrs and dust from the face of brick. Do not bag or sack the wall, but use a bricklayer's brush made with medium soft hair.

Remove all large mortar particles with a hardwood scraper.

If after using the above outlined techniques, additional cleaning of the walls is found necessary, allow the walls to cure one month prior to and at the time the cleaning solution is applied.

Clean the wall only with an approved cleaning solution applied as recommended by the manufacturer. The solution shall be applied with a brush starting at the top of the wall. The use of any proprietary cleaning agents shall first be approved in writing by the manufacturer of the masonry being cleaned and the Architect. The concentration, method of application of the cleaning solution, and method of scraping shall be as outlined on the container by the manufacturer.

High pressure water and sandblasting shall not be used for cleaning.

Immediately after cleaning a small area, the wall shall be rinsed thoroughly with quantities of water.

Protect adjacent surfaces and materials during brick cleaning operations.

After the walls are cleaned, take necessary precautions to insure that other contractors and subcontractors do not damage or soil the walls. Mud protection around the base of walls shall be left in place until the final grading work is done.

END OF SECTION

RELATED DOCUMENTS:

Drawings and general provisions of Contract, including General and Supplementary Conditions and Division-1 Specification sections, apply to work of this section.

PART 1: GENERAL

1.1 SECTION INCLUDES

- A. Concrete masonry units.
- B. Reinforcement, anchorage, and accessories.

1.2 REFERENCES

- A. ACI 530-99 - Building Code Requirements for Masonry Structures.
- B. ACI 530.1-99 - Specifications For Masonry Structures.
- C. ASTM A82 - Cold-Drawn Steel Wire for Concrete Reinforcement.
- D. ASTM A123 - Zinc (Hot-Dipped Galvanized) Coatings on Iron and Steel Products.
- E. ASTM A525 - Steel Sheet, Zinc Coated, (Galvanized) by the Hot-Dip Process.
- F. ASTM A615 - Deformed and Plain Billet Steel Bars for Concrete Reinforcement.
- G. ASTM C55 - Concrete Building Brick.
- H. ASTM C90 - Load-Bearing Concrete Masonry Units.
- I. IMIAC - International Masonry Industry All-Weather Council: Recommended Practices and Guide Specification for Cold Weather Masonry Construction.
- J. IMIAC - International Masonry Industry All-Weather Council: Recommended Practices and Guide Specification for Hot Weather Masonry Construction.
- K. UL - Fire Resistance Directory.

1.3 SUBMITTALS

- A. Shop Drawings: Indicate bars sizes, spacings, locations, reinforcement quantities, bending and cutting schedules, supporting and spacing devices for reinforcement, accessories.
- B. Product Data: Provide data for masonry units and fabricated wire reinforcement and accessories.
- C. Design Data: Indicate required mortar strength, masonry unit assembly strength in all planes, supportive test data.
- D. Manufacturer's Certificate: Certify that Products meet or exceed specified requirements.

1.4 QUALITY ASSURANCE

- A. Perform Work in accordance with ACI 530 and ACI 530.1.
- B. Maintain one copy of each document on site.

1.5 QUALIFICATIONS

- A. Manufacturer: Company specializing in manufacturing the Products specified in this section with minimum five years experience.
- B. Installer: Company specializing in installing the Products specified in this section with minimum five years experience.

1.6 DELIVERY, STORAGE, AND HANDLING

- A. Deliver, store, protect, and handle products in workmanlike manner to avoid damage to units.

1.7 ENVIRONMENTAL REQUIREMENTS

- A. Maintain materials and surrounding air temperature to minimum 40 degrees F 48 hours prior to, during, and 48 hours after completion of masonry work.
- B. Cold Weather Requirements: IMIAC - Recommended Practices and Guide Specifications for Cold Weather Masonry Construction.
- C. Maintain materials and surrounding air temperature to maximum 90 degrees F 48 hours prior to, during, and 48 hours after completion of masonry work.
- D. Hot Weather Requirements: IMIAC - Recommended Practices and Guide Specifications for Hot Weather Masonry Construction.

PART 2: PRODUCTS

2.1 CONCRETE MASONRY UNITS

- A. Hollow Load Bearing Block Units (CMU): ASTM C90, Type I - Moisture Controlled blended light weight with individual unit net area compressive strength of 1900 psi.
- B. Solid Load-Bearing Block Units (CMU): ASTM C90, Type I - Moisture Controlled blended light weight with individual unit net area compressive strength of 1900 psi.
- C. Concrete Brick Units: ASTM C55, Type I - Moisture Controlled blended light weight of same Grade, Type, and Weight as block units with individual unit net area compressive strength of 1900 psi.
- D. Size and Shape: Nominal modular size. Provide special units for 90 and 45 degree corners, bond beams, lintels, and bullnosed corners.

2.2 REINFORCEMENT AND ANCHORAGE

- A. Single and Double Wythe Joint Reinforcement: Truss type; steel wire, hot dip galvanized to ASTM A 153 after fabrication, cold drawn steel wire conforming to ASTM A82, 3/16 inch side rods with No.9 diagonal ties. Reinforcing shall be units no more than two (2) inches smaller in width than the wall thickness and shall be of deformed rods 3/16" side rods and 9 gage diagonal cross rods all hot dipped galvanized.
- B. Joint Reinforcement for CMU/Brick Veneer Cavity Wall: Truss type in CMU backup wall; steel wire, hot dip galvanized to ASTM A 153 after fabrication, cold drawn steel wire conforming to ASTM A82, 3/16 inch side rods with No.9 diagonal ties. Backup wall reinforcing shall be units no more than two (2) inches smaller in width than the wall

thickness and shall be of deformed rods 3/16" side rods and 9 gage diagonal cross rods all galvanized. Veneer anchored with 3/16" keys and hooks, keys are 4-point flush-welded to backup wall rods. Total unit width shall be no more than two (2) inches smaller in width than the total wall thickness. Hooks shall be extended into veneer 1" from exterior face. Provide Hohmann & Barnard Adjusto-Flex-Mesh #AF-H Truss or equivalent.

- C. Provide prefabricated Tees and Corners at all wall intersections.
- D. Interior block partitions shall be reinforced similar to exterior backup walls.
- E. Spacing: Reinforcing for exterior and interior walls shall be 16" o.c. vertically beginning at the finish floor line and provide line of reinforcing one block course and one below all window heads and sills. Extend 16" beyond jambs on each side.
- F. Lap all splices one full panel of reinforcing unit.

2.3 WALL TIES TO STRUCTURAL STEEL:

- A. All exterior and interior masonry walls shall be tied to contiguous steel columns and beams with two-piece adjustable tie units such as, Hohmann and Barnard 359 Weld-On Ties; 1/4" diameter x 8" long hot dip-galvanized bent wire, or equivalent column and beam anchors by Wire-Bond or Heckman, with Hohmann and Barnard VBT-Vee Byna-Tie 3/16" diameter hot-dip galvanized triangular wire ties or approved equal by Wire-Bond or Heckman. Refer to Drawings General Notes.
- B. Space wall ties to columns and beams at 16" oc maximum. Tie anchors may be welded to structural steel with 4 fillet welds 1/8" x 3/4".
- C. Reinforcing Steel: ASTM A615, 60 ksi yield grade, deformed] billet bars, uncoated finish.
- D. Strap Anchors: As indicated on the drawings.

2.4 MORTAR AND GROUT

- A. Mortar: Type "S".
- B. Grout: Ready Mix 3000 psi pea gravel concrete as specified in Section 03300.

2.5 ACCESSORIES

- A. Preformed Control Joints: Neoprene as noted on the drawings.
- B. Joint Filler: Closed cell type as noted on the drawings.
- C. Cleaning Solution: Non-acidic, not harmful to masonry work or adjacent materials.

2.6 LINTELS

- A. Bond beam type and steel lintels as noted on the drawings. Provide steel dowels to top flanges of steel beam lintels as noted on drawings. Provide dowels in bottom flanges of beams beyond the masonry openings as noted on the drawings.

2.6 EMBEDDED BEAMS

- A. Provide dowels in top and bottom flanges of beams embedded in masonry walls as noted on the drawings.

PART 3: EXECUTION

3.1 EXAMINATION

- A. Verify that field conditions are acceptable and are ready to receive work.
- B. Verify items provided by other sections of work are properly sized and located.
- C. Verify that built-in items are in proper location, and ready for roughing into masonry work.

3.2 PREPARATION

- A. Direct and coordinate placement of metal anchors supplied to other Sections.
- B. Provide temporary bracing during installation of masonry work. Maintain in place until building structure provides permanent bracing.

3.3 COURSING

- A. Establish lines, levels, and coursing indicated. Protect from displacement.
- B. Maintain masonry courses to uniform dimension. Form vertical and horizontal joints of uniform thickness.
- C. Concrete Masonry Units:
 - 1. Bond: Running.
 - 2. Coursing: One unit and one mortar joint to equal 8 inches.
 - 3. Mortar Joints: Concave.

3.4 PLACING AND BONDING

- A. Lay solid masonry units in full bed of mortar, with full head joints, uniformly jointed with other work.
- B. Lay hollow masonry units with face shell bedding on head and bed joints.
- C. Buttering corners of joints or excessive furrowing of mortar joints are not permitted.
- D. Remove excess mortar as Work progresses.
- E. Interlock intersections and external corners unless otherwise noted on the drawings.
- F. Do not shift or tap masonry units after mortar has achieved initial set. Where adjustment must be made, remove mortar and replace.
- G. Perform job site cutting of masonry units with proper tools to provide straight, clean, unchipped edges. Prevent broken masonry unit corners or edges.
- H. Cut mortar joints flush where wall tile is scheduled, cement parging is required, resilient base is scheduled, or bitumen damp proofing is applied.
- I. Isolate masonry partitions from vertical structural framing members with a control joint as indicated on drawings.

3.5 REINFORCEMENT AND ANCHORAGE

- A. Install horizontal joint reinforcement 16 inches oc.
- B. Place masonry joint reinforcement in first and second horizontal joints above and below openings. Extend minimum 32 inches each side of opening.
- C. Place joint reinforcement continuous in first and second joint below top of walls.
- D. Lap joint reinforcement ends minimum one full panel.
- E. Support and secure reinforcing vertical bars from displacement with wire rod positioners as noted on the drawings. Maintain bars position within 1/2 inch of indicated position.
- F. Embed anchors attached to structural steel members. Embed anchorages in every second block joint.

3.6 LINTELS

- A. Install reinforced bond beam unit masonry lintels over openings where steel lintels are not scheduled.
- B. Do not splice reinforcing bars in lintels.
- C. Support and secure reinforcing bars from displacement. Maintain position within 1/2 inch of indicated position.
- D. Place and consolidate grout fill without displacing reinforcing.
- E. Allow masonry lintels to attain specified strength before removing temporary supports.
- F. Maintain minimum 8 inch bearing on solid masonry or steel on each side of opening.
- G. Refer to drawings for placement of control joints at ends of lintels.

3.7 GROUTED COMPONENTS

- A. Reinforce 8" wide bond beams with 1 - #5 top bar and, and 1 - #5 bottom bar 1 inch clear from bottom web. Reinforce 12" wide bond beams with 2 - #5 top bars and, and 2 - #5 bottom bars 1 inch clear from bottom web.
- B. Reinforce interior walls with #5 vertical bars spaced at 48" oc unless otherwise noted on the drawings. Place bars in maximum 6'-8" lifts. Lap splices 32", unless otherwise noted on the drawings.
- C. Reinforce exterior walls with #6 vertical bars spaced at 24" oc unless otherwise noted on the drawings. Place bars in maximum 6'-8" lifts. Lap splices 36", unless otherwise noted on the drawings.
- D. Place vertical bars in center of wythe.
- E. Lap splices in horizontal bars minimum 40 bar diameters. Stagger splices in adjacent bars. Dowel horizontal bars through HSS Steel column as noted on the drawings.
- F. Support and secure reinforcing bars from displacement. Maintain position within 1/2 inch of dimensioned position.
- G. Place and consolidate grout fill in 80" maximum lifts in cores containing bars without

displacing reinforcing. Use water reducing plasticizers as required to maintain proper slump for grouting cells 100% solid.

- H. At lintel bearing locations, fill masonry cores with grout for a minimum of 24 inches each side of opening from lintel bearing down to finish floor.
- I. Grout all masonry units 100% solid below finish floor and other locations noted on the drawings.
- J. Lay masonry units with core cells vertically aligned.
- K. Permit mortar to cure 7 days before placing grout.
- L. Reinforce masonry unit cores and cavities with reinforcement bars and grout as indicated on drawings.
- M. Retain vertical reinforcement in position with wire rebar positioners spaced at 48" maximum intervals full height of masonry.
- N. Wet masonry unit surfaces in contact with grout just prior to grout placement.
- O. When grouting is stopped for more than one hour, terminate grout 1-1/2 inches below top of upper masonry unit to form a positive key for subsequent grout placement.
- P. High Lift Grouting: High lift grouting shall not be used for this project.

3.8 CONTROL AND EXPANSION JOINTS

- A. Continue horizontal joint reinforcement through control joints.
- B. Do not continue horizontal joint reinforcement through expansion joints.
- C. Install preformed control joint device in continuous lengths. Seal butt and corner joints in accordance with manufacturer's instructions.
- D. Size control joint in accordance with Section 07900 for sealant performance.
- E. Form expansion joints as detailed.

3.11 BUILT-IN WORK

- A. As work progresses, install built-in metal door and glazed frames, fabricated metal frames, window frames, wood nailing strips, anchor bolts, and other items to be built-in the work and furnished by other sections.
- B. Install built-in items plumb and level.
- C. Bed anchors of metal door [and glazed] frames in adjacent mortar joints. Fill frame voids solid with grout. Fill adjacent masonry cores with grout minimum 24 inches from framed openings.
- D. Do not build in organic materials subject to deterioration.

3.12 TOLERANCES

- A. Maximum Variation From Alignment: 1/4 inch.
- B. Maximum Variation From Unit to Adjacent Unit: 1/32 inch.

- C. Maximum Variation from Plane of Wall: 1/4 inch in 10 ft and total 1/2 inch overall.
- D. Maximum Variation from Plumb: 1/4 inch per story.
- E. Maximum Variation from Level Coursing: 1/8 inch in 3 ft and 1/4 inch in 10 ft; 1/2 inch in 30 ft.
- F. Maximum Variation of Joint Thickness: 1/8 inch in 3 ft.

3.13 CUTTING AND FITTING

- A. Saw cut or core drill for neat fit at chases, pipes, conduit, sleeves. Coordinate with other sections of work to provide correct size, shape, and location. Fill space around penetrating devices with approved firestop materials.
- B. Obtain approval prior to cutting or fitting masonry work not indicated or where appearance or strength of masonry work may be impaired.

3.14 CLEANING

- A. Clean work with non acidic and non staining high pressure wash.
- B. Remove excess mortar and mortar smears as work progresses.
- C. Replace defective mortar. Match adjacent work.
- D. Clean soiled surfaces with cleaning solution.
- E. Use non-metallic tools in cleaning operations.

3.15 PROTECTION OF FINISHED WORK

- A. Protect finished Work form damage.
- B. Without damaging completed work, provide protective boards at exposed external corners which may be damaged by construction activities.

END OF SECTION

Water Penetration Resistance - Construction and Workmanship

Abstract: This *Technical Note* covers essential construction practices needed to assure water-resistant brick masonry. Procedures for preparing materials to be used in brick construction are recommended, including proper storage, handling and preparation of brick, mortar, grout and flashing. Good workmanship practices are described, including the complete filling of all mortar joints, tooling of mortar joints for exterior exposure and covering unfinished brick masonry walls to protect them from moisture.

Key Words: air space, brick, construction, flashing, initial rate of absorption, joints, mortar, tooling, weeps, workmanship.

SUMMARY OF RECOMMENDATIONS:

General

- Store materials on the job site to avoid wetting and contamination
- For drainage walls, keep the air space free of excessive mortar droppings
- Do not disturb newly laid masonry
- Cover tops of unfinished walls until adjacent construction protects them from water entry

Brick

- Pre-wet brick with a field measured initial rate of absorption (IRA) exceeding 30 g/min•30 in.² (30 g/min•194 cm²)

Mortar

- When mixing mortar, use accurate batching measurements and maximum amount of water that produces a workable mortar
- For brick with an IRA exceeding 30 g/min•30 in.² (30 g/min•194 cm²), increase water or maximize water retention by increasing lime proportions within limits of ASTM C 270
- For brick with an IRA lower than 5 g/min•30 in.² (5 g/min•194 cm²), reduce water or minimize water retention by decreasing lime proportions within limits of ASTM C 270

Joints

- In exterior wythes, completely fill all mortar joints intended to have mortar
- Minimize furrowing of bed joints and prohibit slushing of head joints
- Fill collar joints completely with grout or mortar, preferably grout; do not slush collar joints
- Tool mortar joints when thumbprint hard with a concave, "V" or grapevine jointer

Flashing and Weeps

- Do not stop flashing behind face of brickwork
- Where required, turn up flashing ends into head joint a minimum of 1 in. (25.4 mm) to form end dams
- Lap continuous flashing pieces at least 6 in. (152 mm) and seal laps
- Where installed flashing is pierced, make watertight with sealant or mastic compatible with flashing
- Install weeps immediately above flashing

INTRODUCTION

The best design, detailing and materials will not compensate for poor construction practices and workmanship. Proper construction practices, including preparation of materials and workmanship, are essential to achieve a water-resistant brick masonry wall.

This *Technical Note* discusses construction techniques and workmanship and is the third in a series of *Technical Notes* addressing water penetration resistance of brick masonry. Other *Technical Notes* in the series address brickwork design and details (7), materials (7A) and condensation (7C and 7D). Maintenance of brick masonry is addressed in *Technical Note* 46. All of these items are essential to obtain water-resistant brick masonry walls.

PREPARATION OF MATERIALS

Preparation of masonry materials before bricklaying begins is very important. Specific procedures must be followed to ensure satisfactory performance and avoid future problems. Preparation includes material storage, mixing mortar and grout and, in some cases, wetting the brick.

Storage of Materials

All materials at the jobsite should be stored to avoid contamination. Masonry units, mortar materials, ties and reinforcement should be stored off the ground, preferably in a dry location. In addition, all materials should be covered with tarpaulins or other weather-resistant materials to protect them from the elements.

Wetting Brick

Brick with an initial rate of absorption (IRA) greater than 30 g/min•30 in.² (30 g/min•194 cm²) at the time of laying tend to draw too much moisture from the mortar before initial set. As a result, construction practices should be altered when using brick with high IRA to achieve strong, water-resistant masonry. The IRA of brick in the field will typically be less than that reported in laboratory tests. Laboratory test results may be used to determine if measuring IRA in the field is necessary. ASTM C 67, Test Methods for Sampling and Testing Brick and Structural Clay Tile, includes a standard procedure for measuring IRA in the field.

A crude method of indicating whether brick need to be wetted prior to placement consists of drawing, with a wax pencil, a circle 1 in. (25.4 mm) in diameter on the brick surface that will be in contact with the mortar. A quarter can be used as a guide for the circle. With a medicine dropper, place 20 drops of water inside this circle and note the time required for the water to be absorbed. If the time exceeds 1½ minutes, the brick should not need wetting; if less than 1½ minutes, adjustments to typical construction practice are recommended.

Specification for Masonry Structures [Ref. 4] requires that brick with an IRA exceeding 30 g/min•30 in.² (30 g/min•194 cm²) be wetted prior to laying to produce an IRA less than 30 g/min•30 in.² (30 g/min•194 cm²) when the units are placed. However, execution of this method may be impractical on large-scale construction projects and the contractor may consider other alternatives, as discussed in the following section, Mixing of Mortar and Grout.

If brick are to be wetted, the method of wetting is very important. Sprinkling or dipping the brick in a bucket of water just before laying would produce the surface wet condition which may not be sufficient, as shown in [Figure 1b](#). The units should have a saturated interior, but be surface dry at the time of laying, as shown in [Figure 1d](#).

Satisfactory procedures for wetting the brick consist of letting water run on the cubes or pallets of brick, or placing them in a large tank of water. This should be done the day before the units are laid, or not later than several hours before the units will be used so that the surfaces have an opportunity to dry before the brick are laid. Wetting low-absorption brick or excessive wetting of brick may result in saturation, as shown in [Figure 1c](#). This can cause “bleeding” of the mortar joints and “floating” of the brick.

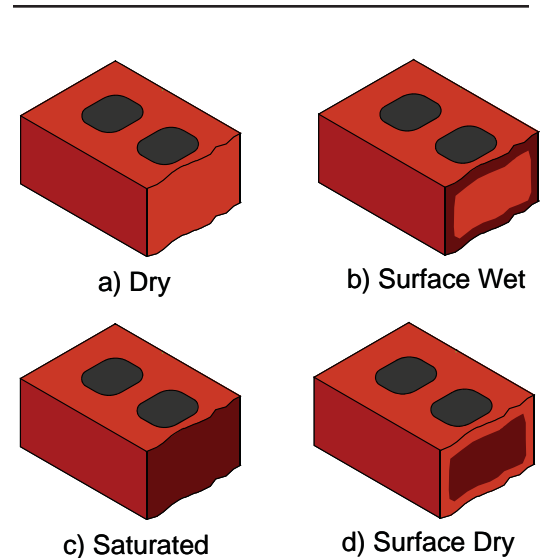

Figure 1
Moisture Content of Brick

Mixing of Mortar and Grout

Typically, a high water content in the mortar is necessary to obtain complete and strong bond between mortar and brick. In general the mortar should be mixed with the maximum amount of water that produces a workable mortar. Factors such as the jobsite environment and the IRA of the brick should be considered when determining the proper amount of water to include in the mortar.

Mortar to be used with brick that have an IRA greater than 30 g/min•30 in.² (30 g/min•194 cm²) should be mixed to maximize water retention by increasing mixing water or lime content within the limits of ASTM C 270. This is particularly important when pre-wetting the brick to reduce their IRA is impossible or impractical. Admixtures designed to increase the water retention of the mortar may also be used to improve the compatibility of mortar with high IRA brick. Only admixtures with test data showing no deleterious effects should be used.

Mortar for use with brick that have an IRA less than 5 g/min•30 in.² (5 g/min•194 cm²) should be mixed with reduced amounts of water or lime to minimize water retention. Lime proportions should remain within the limits of ASTM C 270.

When brick with widely different absorption rates are used together in brickwork, it is important to maintain the correct water content in the mortar used with the different brick.

All cementitious materials and aggregates must be mixed for at least 3 minutes and not more than 5 minutes in a mechanical batch mixer. If, after initial mixing, the mortar stiffens due to the loss of water by evaporation, addi-

tional water should be added and the mortar remixed (retempered). All mortar should be used within 2½ hr (2 hr in hot weather conditions, see *Technical Note 1*) of initial mixing and grout should be used within 1½ hour of introducing water into the mix. No mortar or grout should be used after it has begun to set.

One of the most common problems with mortar is oversanding. Oversanded mortar is harsh, unworkable and results in poor extent of bond and reduced bond strength, thus increasing the potential for water penetration problems. The cause of oversanding is frequently the use of the shovel method of measuring the sand. The amount of sand that a shovel will hold varies depending on the moisture content of the sand, the person doing the shoveling and the different size of shovels used on the jobsite. To alleviate this problem, proper batching methods must be used. Measurement of sand by shovel should not be permitted without periodically gauging the shovel count using a bucket or box of known volume. *Technical Note 8B* provides detailed guidelines for various methods of more accurately batching mortar.

Blending of Brick

While not related to water penetration resistance, blending of brick at the jobsite is an important preparation task related to workmanship and the acceptable appearance of brickwork. Because brick is made from natural materials that vary in physical properties, variations in color may occur between production runs and occasionally within the same run. Modern manufacturing processes use automatic equipment which may not permit inspection of each brick, also resulting in minor color and texture variations. For these reasons, straps of brick from different cubes should be placed together around the wall. The mason should then select brick from adjacent straps when laying a given section of brickwork. By blending the brick throughout the wall in this manner, the effect of potential color variations on the finished brickwork is minimized.

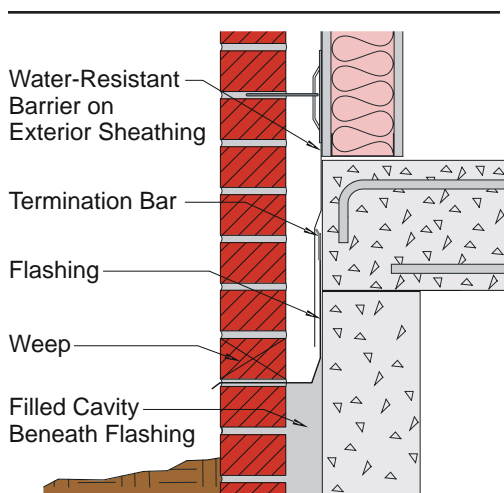

Figure 2
Wall Base Flashing Detail

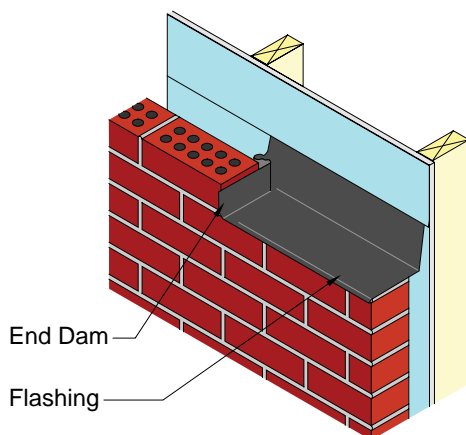

Figure 3
End Dam Detail

WORKMANSHIP

The importance of good workmanship to attain quality brickwork cannot be overemphasized. While design and the quality of materials contribute to the water penetration resistance of brickwork, workmanship is a highly important factor in the construction of water-resistant masonry.

Placing Flashing and Weeps

Flashing must be installed properly and integrated with adjacent materials to form an impervious barrier to moisture movement. The flashing should be wide enough to start outside the exterior face of the brick wythe, extend across the cavity, and turn up vertically against the backing or interior wythe at least 8 in. (203 mm). The top (vertical) edge should be placed in a mortar joint of the backing wythe, in a reglet in concrete backing, or attached to sheathing with a termination bar, as shown in *Figure 2*. Sections of flashing are to be overlapped at least 6 in. (152 mm) and the lap sealed with a compatible adhesive. Water-resistant sheet membranes should overlap the flashing in a shingle fashion by at least 6 in. (152 mm).

Flashing that is placed so that the outside edge projects from the face of the wall may be cut flush with the face of the brickwork. In no circumstances should the flashing be stopped behind the face of the brickwork. Continuity at corners and returns is achieved by cutting and folding straight sections or using preformed corner pieces. Discontinuous flashing should terminate with an end dam in a head joint, rising at least 1 in. (25.4 mm) as shown in *Figure 3*.

Flashing must be placed without punctures or tears. Openings created for reinforcement or anchors must be closed with a compatible sealant. Protection may be needed around bolts fastening shelf angles to the structure.

Weeps are required, and should be formed in mortar joints immediately above the flashing. Open head joints, formed by leaving mortar out of a joint, are the recommended type of weep. Open head joint weeps should be at least 2 in. (51 mm) high. Weep openings are permitted by most building codes to have a minimum diameter of $\frac{3}{16}$ in. (4.8 mm). The practice of specifying the installation of weeps one or more courses of brick above the flashing can cause a backup of water and is not recommended. Non-corrosive metal, mesh or plastic screens can be installed in open head joint weeps if desired.

Spacing of open head joint weeps at no more than 24 in. (610 mm) on center is recommended. Spacing of wick and tube weeps is recommended at no more than 16 in. (406 mm) on center. Weep spacing is permitted by most building codes up to 33 in. (838 mm) on center. If other than an open head joint weep is used, be sure the weep is clear of all mortar to allow the wall to drain (see *Technical Note 21C*). Rope wicks should be flush with, or extend $\frac{1}{2}$ in. (12.7 mm) beyond the face of the wall to promote evaporation. The rope should continue into the bottom of the air space, placed along the back of the brick and be at least 16 in. (406 mm) long.

Filling Mortar Joints

To reduce water penetration, there is no substitute for proper filling of all mortar joints that are designed to receive mortar. Improperly filled mortar joints can result in leaky walls, reduce the strength of masonry, and may contribute to disintegration and cracking due to water penetration and subsequent freezing and thawing.

A uniform bed of mortar should be spread over only a few brick, and furrowed lightly, if at all. Filled joints result when plenty of mortar is placed on the end of the brick to be laid and it is shoved into place so that mortar is squeezed out of the top of the head joint, as shown in [Photo 1](#). After placement, mortar squeezed out of bed joint should be cut off prior to tooling, as shown in [Photo 2](#). When placing closures, plenty of mortar is needed on the ends of brick in place and on the ends of the brick to be laid. The closure should be shoved into place without disturbing brick on either side, as shown in [Photo 3](#).

Bed Joints. A bed joint is the horizontal layer of mortar on which a brick is laid. The length of time between placing the bed joint mortar and laying the succeeding brick influences the resulting bond. If too long a time elapses, poor extent of bond will result. Brick should be laid within 1 minute or so after the mortar is placed.

For solid brick, bed joints should be constructed without deep furrowing of the mortar, as full bed joints (covering the entire bedding surface) are an inherent requirement for water-resistant brick masonry construction. For hollow brick, bed joints may be laid with face shell bedding (mortar placed only on the front and back face shells). Both face shells must be completely covered with mortar.

Head Joints. A head joint, sometimes called a cross joint, is the vertical mortar joint between two brick. For both solid and hollow brick it is important that head joints be completely filled. The best head joints are formed by completely buttering the ends of the brick with mortar and shoving the brick into place against previously laid brick.



Photo 1
Shoving Brick into Place



Photo 2
Cutting Excess Mortar



Photo 3
Placing the Closure

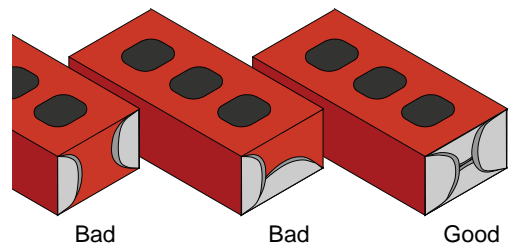

Figure 4
Head Joints



Photo 4
Concave Mortar Joints



Photo 5
"V" Mortar Joints

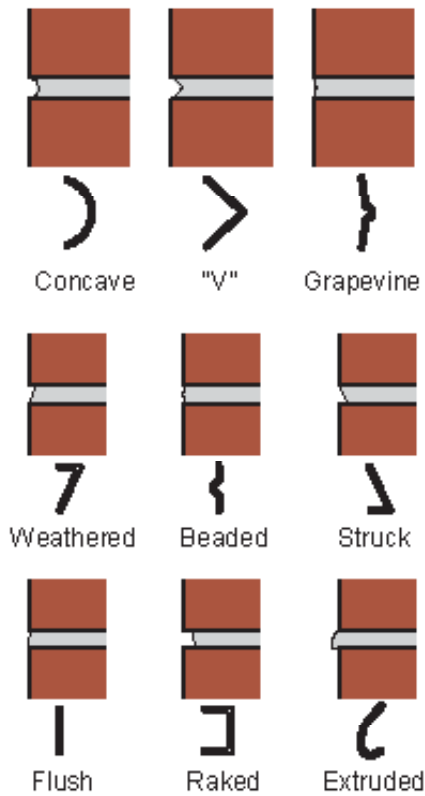

Figure 5
Typical Mortar Joints

"Slushing" ("throwing" mortar into the joint with the edge of a trowel) does not adequately fill joints or compact the mortar, resulting in joints that are less resistant to water penetration. The results of head joint forming are shown in [Figure 4](#).

Tooling of Mortar Joints

Proper tooling, or "striking", of mortar joints helps seal the wall surface against moisture penetration. Mortar joints should be tooled when they are "thumbprint" hard, (pressing the thumb into the mortar leaves an indentation, but no mortar is transferred to the thumb) with a jointer slightly larger than the joint. It is important that joints are tooled at the appropriate time as this affects both their effectiveness and appearance. Joints that are tooled too early often smear and result in rough joints. If tooling is delayed too long the surface of the joint cannot be properly compressed and sealed to the adjacent brick. Each portion of the completed brickwork should be allowed to set for the same amount of time before tooling in order to ensure a uniform mortar shade. Early tooling often results in joints of a lighter color. Later tooling results in darker shades.

Concave, "V" and grapevine joints best resist water penetration in exterior brickwork. These joints produce a more dense and weather-tight surface, as the mortar is pressed against the brick, as shown in [Photos 4 and 5](#). For interior masonry work, other joints such as the weathered, beaded, struck, flush, raked or extruded joints shown in [Figure 5](#) can also be used.

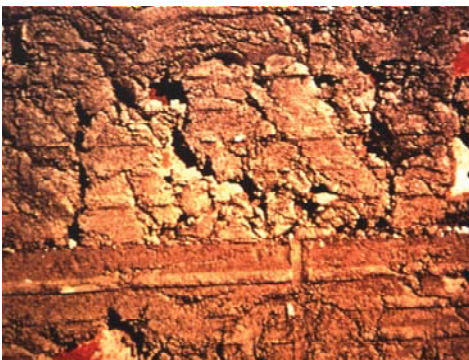

Photo 6
Poorly Filled Collar Joint

Collar Joints

The vertical, longitudinal joint between wythes of masonry is called a collar joint. The manner in which these joints are filled is very important. Grouting is the most effective method of ensuring that collar joints are completely filled. However, grouting spaces less than 3/4 in. (19.1 mm) is not permitted. Mortar protrusions (fins) that extend more than 1/2 in. (12.7 mm) into a cell or cavity that will be grouted must be removed prior to grouting. For mortar-filled collar joints, the outer face of the inner masonry wythe should be parged and the back of brick in the exterior wythe buttered in order to fill the collar joint.

"Slushing" of collar joints is not effective since it does not completely fill all voids in the joint, as shown in [Photo 6](#). Frequently, the mortar is

caught and held before it reaches the bottom of the joint, leaving openings between the face brick and the backing. Even when this space is filled, there is no way to compact the mortar. The mortar does not bond with the brick over its entire surface and channels are left between the mortar and the brick. Some of these channels may allow water to reach the back of the wall. A properly constructed collar joint is completely filled with grout or mortar.

Parging

Parging is the process of applying a coat of portland cement mortar to masonry. Parging the outer face of the inner wythe of a multiwythe wall with Type M or S mortar as damp proofing may help resist rain penetration and can also reduce air leakage. Membranes or liquid-applied materials usually provide superior performance to parging, which will crack if the wythe cracks. However, parging can provide a smooth base for these materials. If parging alone is to resist water penetration, proper curing is necessary to reduce shrinkage cracks. Parging the back side of the exterior wythe is not recommended for drainage-type walls, as this may result in more debris in the air space or break the brick/mortar bond.

The face of the wall to be parged must not have any mortar protrusions. Protruding mortar can cause bond breaks in the parge coat, resulting in a leaky wall. When applied in multiple layers, each should be a minimum thickness of ¼ in. (6.4 mm). The first coat should be allowed to partially set, roughened, and allowed to cure for 24 hours. It is then moistened for application of the second coat. The parged surface should be troweled smooth so that it sheds water easily. When completed in adjacent areas, the edges of the parging should be feathered and new parging should overlap existing parging by a minimum of 6 in. (152 mm). Lap joints should be spaced no closer than 6 feet (1.83 m).

Keeping Air Spaces Clean

In a drainage wall system, such as a cavity wall or an anchored veneer wall, it is essential that the air space be kept clean. If it is not, mortar droppings may clog the weeps, protrusions may span the air space and water penetration to the interior may occur.

To the greatest extent possible, mortar droppings should be prevented from falling into the air space or cavity. An aid to prevent this is to bevel the bed joint away from the air space or cavity, as shown in [Figure 6](#). When brick are laid on a beveled bed joint, a minimum of mortar is squeezed out of the joint, as shown in [Photo 7](#). The mortar squeezed from the joints on the air space or cavity side may be troweled onto the units. This same procedure may be used for laying the exterior wythes of grouted and reinforced brick cavity walls.

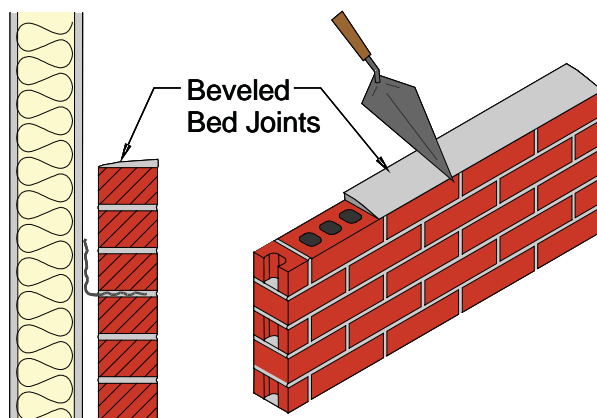

Figure 6
Beveled Bed Joints

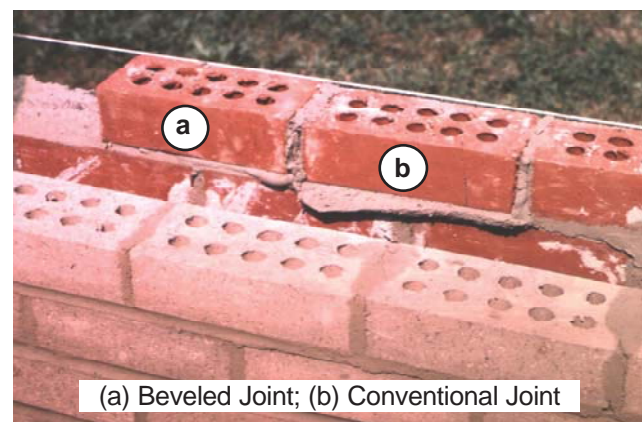

Photo 7
Beveled and Conventional Mortar Joints

Another method allows access to the base of the cavity for cleaning. When the brickwork is initially constructed, every third brick or so in the course above the flashing of the exterior wythe is omitted. Once the brickwork is complete, mortar droppings at the base of the cavity can be easily removed and weeps provided when the omitted brick are placed in the wall with mortar.

Alternately, a wooden or metal strip, slightly smaller than the cavity width, can be placed in the air space. This strip rests on the wall ties as the wall is built. Wire or rope is attached to the strip so the strip can be lifted out as the mason builds the wall. Care should be taken when raising or removing the strip to not disturb the brickwork.

Drainage materials and mortar dropping control devices may also be used to keep the air space adjacent to the weeps free from mortar. Use of these devices does not guarantee that bridging of the air space will not occur, thus the amount of mortar droppings should be limited as much as possible.

Disturbance of Newly Laid Masonry

Newly laid brick should never be pushed, shoved, tapped or otherwise disturbed once they are laid in their final position and the mortar has begun to set. Any disturbance at this point will break the bond and may lead to a leak. If adjustments are necessary, the incorrectly placed brick should be removed and re-laid in fresh mortar.

Protection of Unfinished Brickwork

Covering of masonry walls at the end of each work day, and especially in times of inclement weather, is essential for satisfactory performance. Covering unfinished walls with tarpaulins or other water-resistant materials, securely tied or weighted in position, should be rigorously enforced. Mortar boards, scaffold planks and light plastic sheets weighted with brick should not be accepted as suitable cover. Metal clamps, similar to bicycle clips, are commercially available in a variety of sizes to meet various wall thicknesses. These are used in conjunction with plastic sheets or water-repellent tarpaulins and offer excellent protection for extended periods of time.

Tops of walls should also be covered after the mason's work is finished if a permanent coping is not attached immediately after the brickwork is completed. Protection of openings in brickwork such as those for windows, movement joints, etc. should also be considered as they may allow moisture ingress from rain and snow and can lead to moisture-related problems such as efflorescence, and in some cases could affect the final mortar color.

SUMMARY

Quality construction practices and good workmanship are essential to achieve brickwork that is resistant to water penetration. This *Technical Note* does not cover all construction practices, but describes material storage and preparation procedures, construction practices and installation techniques that are indicative of high quality and, when combined with proper design, detailing and materials, result in brickwork that is resistant to water penetration.

The information and suggestions contained in this Technical Note are based on the available data and the combined experience of engineering staff and members of the Brick Industry Association. The information contained herein must be used in conjunction with good technical judgment and a basic understanding of the properties of brick masonry. Final decisions on the use of the information contained in this Technical Note are not within the purview of the Brick Industry Association and must rest with the project architect, engineer and owner.

REFERENCES

1. *The BDA Guide to Successful Brickwork*, Second Edition, The Brick Development Association, Arnold (a member of the Hodder Headline Group), London, England, 2000.
2. Drysdale, R.G., Hamid, A.A., and Baker, L.R., *Masonry Structures: Behavior and Design*, Second Edition, The Masonry Society, Boulder, CO, 1999.
3. Koski, J.A., "Waterproof the Backup Wythe," *Masonry Construction*, August 1992.
4. *Specification for Masonry Structures*, ACI 530.1-05/ASCE 6-05/TMS 602-05, The Masonry Society, Boulder, CO, 2005.

RELATED DOCUMENTS:

Drawings and general provisions of Contract, including General and Supplementary Conditions and Division-1 Specification sections, apply to work of this section.

PART 1: GENERAL

SECTION INCLUDES

- A. Structural steel columns, beams, lintels, trusses, rod bracing, and other steel framing members.
- B. Base plates, column anchor bolts,
- C. Steel to steel connection bolts.

REFERENCES

- A. ASTM A36, A992 –Structural Steel.
- B. ASTM A53 – Grade B Hot-Dipped, Zinc-coated Welded and Seamless Steel Pipe.
- C. ASTM A108 - Steel Bars, Carbon, Cold-Finished, Standard Quality.
- D. ASTM A123 - Zinc (Hot Dipped Galvanized) Coatings on Iron and Steel Products.
- E. ASTM A153 - Zinc Coating (Hot Dip) on Iron and Steel Hardware.
- F. ASTM A307 - Carbon Steel Externally Threaded Standard Fasteners.
- G. ASTM A325 - High Strength Bolts for Structural Steel Joints.
- H. ASTM A490 - Quenched and Tempered Alloy Steel Bolts for Structural Steel Joints.
- I. ASTM A500 – Grade B Cold-Formed Welded and Seamless Carbon Steel Structural Tubing in Round and Rectangular Shapes.
- J. ASTM A501 - Hot-Formed Welded and Seamless Carbon Steel Structural Tubing.
- K. ASTM A572 - High Strength Low Alloy Columbium-Vanadium Steel of Structural Quality.
- L. ASTM F1554 – Anchor Rods
- M. AWS A2.0 - Standard Welding Symbols.
- N. AWS D1.1 - Structural Welding Code.
- O. AISC - Specification for the Design, Fabrication and Erection of Structural Steel for Buildings – Allowable Stress Design..
- P. AISC - Specification for Architectural Exposed Structural Steel.
- Q. SSPC - Steel Structures Painting Council.

SUBMITTALS

- A. Shop Drawings:

1. Indicate dimensions, elevations, profiles, sizes, spacing, and locations of structural members, miscellaneous members, attachments, and fasteners.
 2. Connections detailed fully. Any connections which are not standard AISC connections shall be marked as such by the fabricator on the submittal.
 3. Indicate welded connections with AWS A2.0 welding symbols. Indicate net weld lengths and returns.
 4. All truss connections shall be fully welded all around. All truss members shall be fully closed so as not to allow moisture to collect inside.
- B. Manufacturer's Mill Certificate: Certify that products meet or exceed specified requirements.
- C. Mill Test Reports: Submit indicating structural strength, destructive and non-destructive test analysis.
- D. Welders Certificates: Certify welders employed on the Work, verifying AWS qualification within the previous 12 months.

QUALITY ASSURANCE

- A. Fabricate structural steel members in accordance with AISC - Specification for the Design, Fabrication and Erection of Structural Steel for Buildings.
- B. Perform Exposed Work in accordance with AISC - Specification for Architectural Exposed Structural Steel.

QUALIFICATIONS

- A. Fabricator: Company specializing in performing the work of this Section with minimum five years documented experience.
- B. NOT USED

FIELD MEASUREMENTS

- A. Verify that field measurements are as shown on Drawings.

PART 2 PRODUCTS

MATERIALS

- A. Structural Steel Wide Flange Members: Certified to ASTM A992 (Fy = 50 ksi).
- B. Plates, Angles, Bars: Certified to ASTM A36 (Fy = 36 ksi)
- C. Rods: to ASTM A36 (Fy = 36 ksi)
- D. Structural Tubing: ASTM A500, Grade B (Fy = 46 ksi).
- E. Pipe: ASTM A53, Grade B (Fy = 35 ksi).
- F. Bolts, Nuts, and Washers: ASTM A325.

- G. Anchor Rods: F1554 Grade 50.
- H. Welding Materials: AWS D1.1; type required for materials being welded.
- I. Headed Shear Studs: ASTM A108 Type B, Fu = 60 ksi.
- J. Grout: Non-shrink type, pre-mixed compound consisting of non-metallic aggregate, cement, water reducing and plasticizing additives, capable of developing a minimum compressive strength of 7000 psi at 7 days.
- K. Shop Applied Primer - Epoxy Finished Members: One coat of green solvent based inorganic zinc. Shop primer shall be certified to be compatible with the intumescent fireproofing and UL assemblies, and with epoxy systems as applicable and specified. Reference Section 09900.
- L. Shop Applied Primer – Exposed and Intumescent Fireproofed Members: One coat of grey oxide alkyd. Shop primer shall be certified to be compatible with the intumescent fireproofing and UL assemblies, as applicable and specified. Reference Section 09900.
- M. Shop Applied Primer – Cementitious Spray-on Fireproofed Members: Not required to be primed. Shop primer shall be certified to be compatible with the fireproofing UL assemblies.

FINISH

- A. Prepare structural component surfaces required to be shop primed in accordance with SSPC SP-2, SP-3 or SP-6 as applicable for the final finish type. Reference Section 09900.
- B. Shop priming is required for all building interior exposed to view structural steel members. Shop priming not required for structural steel members where steel is to be enclosed and concealed from view in walls and ceilings or encased in concrete or masonry. Shop primer shall be certified to be compatible with the intumescent fireproofing and epoxy systems and applicable UL assemblies. Apply sufficient primer to insure required dry film thicknesses specified. Reference Section 09900.
 - 1. Members finished with epoxy systems: 2-3 mils DFT, SP-6 surface preparation
 - 2. Members finished with alkyd systems: 2 mils DFT, SP-2 or SP-3 surface preparation
- C. Unless otherwise noted, all exposed exterior structural steel members and steel framing shall be hot-dipped galvanized after fabrication to comply with ASTM A123 G60 standards, including but not limited to: steel pipe, structural steel columns (tubes or wide flanged), beams (tubes or wide flanged), connections, steel angle framing. Reference Section 09900 for paint primer and top coats.
- D. Members to receive cementitious spray-on fireproofing are not required to be primed. Shop primer shall be certified to be compatible with the fireproofing UL assemblies.
- E. Top flanges of beams receiving headed shear studs embedded within concrete shall not be primed.
- F. Lintels in exterior walls shall be hot dip galvanized to G60 standards, after fabrication. All seams in built-up members to be hot dip galvanized such as beam and plate lintels shall be seal welded. Field paint lintels as per 09900.

PART 3 EXECUTION

EXAMINATION

- A. Verify that field conditions are acceptable and are ready to receive work.
- B. Verify that lay down areas are sufficient, clean, level, and of sufficient strength and stability to support safely members and handling equipment.

HANDLING AND STORAGE

- A. Provide proper equipment too safely off load material to prevent damage.
- B. Provide adequate dunnage and skids to keep steel from getting muddy and dirty.
- C. Store steel in such a manner to prevent the accumulation of water and debris.
- D. Do not erect steel that is muddy or stained with any deleterious material. Clean steel if necessary before erection.

ERECTION

- A. Allow for erection loads, and for sufficient temporary bracing to maintain structure safe, plumb, and in true alignment until completion of erection and installation of permanent bracing.
- B. Do not field cut or alter structural members without approval of Architect/Engineer.
- C. After erection, clean and prime paint welds, abrasions, and surfaces where shop primer has been disturbed, deteriorated or damaged.
- D. All eaves shall be aligned to be straight and true. All joist extended ends at the eaves and all HSS outriggers at the gables shall be pulled into alignment and securely welded to the continuous edge plate or angle as applicable. Edge plates and angles shall be string lined for straightness.
- E. Gable outriggers shall be accurately laid out to fit under the wide flute of the metal deck and shall be welded to the top of the affected joists. The metal deck shall be puddle welded to the top of the HSS outriggers at 12" o.c. in addition to welding to the supporting joists.
- F. The bent plate ridge plate shall be aligned vertically and horizontally and shall be securely welded to the ends of the joist extended ends to form straight and level ridge.
- G. The continuous eave bent plates and gable edge angles shall be butt welded straight and full strength at joints. Provide a break in the continuous bent plate and angle members over supports at maximum 40 foot intervals. The minimum length of these members shall be 20 feet. These break joints shall be over a support and shall be welded thereto.
- H. Grout under column base plates to get full uniform bearing.

FIELD QUALITY CONTROL

- A. Field inspection will be performed by the Architect.
- B. All connection bolts and field welds shall be inspected by an independent testing lab selected by the owner and paid by the contractor from the material testing allowance.
- C. All steel beam to beam, beam to column, brace connections, and joist girder to column. Joists to joist girder, and joists to column connection bolts shall be tightened to AISC turn of the nut criteria.
- D. Shop welds and fabrication quality shall be certified by the materials testing laboratory. At the

option of the lab the inspection may be conducted in the field after delivery or at the fabrication plant during fabrication and/or prior to shipment.

- E. All structural steel members shall be inspected by the testing laboratory for sweep, camber, and twist to comply with ASTM A6 and AISC Code of Standard Practice for fabricated structural steel. Types of weld tests and frequency of tests shall comply with AWS D1.1 - Structural Welding Code, 2006 Edition.
- F. All out of tolerance members shall be corrected prior to erection by the contractor.
- G. All connections with misfitting bolts shall be field welded as directed by the inspector to fully compensate for the strength of the misfitting bolts.

END OF SECTION

RELATED DOCUMENTS:

Drawings and general provisions of Contract, including General and Supplementary Conditions and Division-1 Specification sections, apply to work of this section.

PART 1: GENERAL

SECTION INCLUDES

- A. Open web steel joists, joist girders, with bridging, extended ends, bolted bridging bolts, and other joist accessories.

REFERENCES

- A. ASTM A36/A36M, A992 - Structural Steel.
- B. ASTM A500 – Grade B
- C. ASTM A242/242M - High Strength Low Alloy Structural Steel.
- D. ASTM A529/529M Grade 50 - High Strength Carbon-Manganese Steel of Structural Quality.
- E. ASTM A572/572M Grade 50 - High Strength Low Alloy Columbian-Vanadium Steel of Structural Quality.
- F. ASTM A588/588M - High Strength Low Alloy with 50 kis Minimum Yield Point to 4 inches thick.
- G. ASTM A606 - Steel Sheet and Strip, Hot Rolled and Cold Rolled High-Strength Low Alloy, with Improved Corrosion Resistance.
- H. ASTM A1011/A1011M - Steel, Sheet and Strip Hot Rolled, Carbon, Structural High Strength Low-Alloy and High Strength Low Alloy with Improved Formability.
- I. ASTM A1008/A1008M - Steel, Sheet Cold Rolled, Carbon, Structural High Strength Low-Alloy and High Strength Low Alloy with Improved Formability.
- J. ASTM A108 - Steel Bars, Carbon, Cold-Finished, Standard Quality.
- K. ASTM A307 - Carbon Steel Threaded Standard Fasteners.
- L. ASTM A325 - High Strength Bolts for Structural Steel Joints.
- M. ASTM A53 – Grade B
- N. AWS D1.1 - Structural Welding Code.
- O. FM - Roof Assembly Classifications.
- P. SJI (Steel Joist Institute) - Specifications, Load tables, and Weight Tables for Steel Joists and Joist Girders.
- Q. SSPC (Steel Structures Painting Council) - Steel Structures Painting Manual.
- R. UL - Fire Resistance Directory.
- W. Warnock Hersey - Certification Listings.

SUBMITTALS FOR REVIEW

- A. Shop Drawings and Erection Plans and Diagrams:
 - 1. Indicate standard designations, configuration, sizes, spacing, locations of joists, joist girders, trusses, top and bottom chord extensions, bolted connections, welded connections.
 - 2. Coding of bridging, connections, attachments, and accessories for complete installation.
 - 3. Cambers in adjacent members shall be uniformly controlled to be no greater than required by SJI standards.

SUBMITTALS FOR INFORMATION

- A. Welders' Certificates: Submit manufacturer's certificates, certifying welders employed on the Work, verifying AWS qualification within the previous 12 months.

QUALITY ASSURANCE

- A. Perform Work in accordance with SJI, Load Tables, and Weight Tables.
- B. Maintain one copy of each shop drawing document on site.
- C. Fabricator: Company specializing in performing the work of this section with minimum five years experience.
- D. Erector: Company specializing in performing the work of this section with minimum five years experience.
- E. Joists and Joist Girders and their connections not detailed on the Drawings shall be designed by Professional Engineer experienced in design of this work and licensed in the State of North Carolina and employed by the joist supplier.

DELIVERY, STORAGE, AND PROTECTION

- A. Material and Equipment: Transport, handle, store, and protect products to SJI requirements so as not to damage, bend or otherwise distort members from their fabrication conditions.

PART 2 PRODUCTS

MATERIALS

- A. Open Web Joists Members: SJI Type K, KCS, LH Longspan, G series Joist Girders.
- B. Bolts, Nuts and Washers: ASTM A325.
- C. Structural Steel For Supplementary Framing, Joist Extensions, and Joists Substitutes.
- D. Welding Materials: AWS D1.1; type required for materials being welded.
- E. Shop and Touch-Up Primer:
 - 1. SSPC 15, Type 1, grey oxide alkyd for all joists. Reference 09900.
 - 2. Joists to receive cementitious spray-on fireproofing do not require primer. Primer if used shall be certified to compatible with fireproofing UL assemblies.

FABRICATION

- A. Provide bottom and top chord extensions as indicated. Top chord extensions shall be continuous smooth straight extensions of the joist top chord without bends or sweeps.
- B. Fabricate to achieve minimum end bearing of 2-1/2 inches on steel for K series, 5" for LH series, 6" for G series joist girders. Refer to drawings for additional bearing requirements for sloping joists and joist girders.
- C. Provide for 3/4" diameter A325 connection bolts for joist to joist girder, and joist to column, and joist to beam connections. Provide field welded connections for all field bolted connections after adjustment and plumbing of the structural frame.
- D. Provide 1/2" ASTM A307 bolts for all field bolted diagonal bridging requirements.
- E. Drill or punch not burn holes in girder chords and flanges and column cap plates necessary for attachment of bolted joists.

FINISH

- A. Prepare joist component surfaces to receive shop primer in accordance with SJI standards.
- B. Shop prime all joists and joist accessories. Joists to receive cementitious spray-on fireproofing do not require primer. Primer if used shall be certified to compatible with fireproofing UL assemblies.

SOURCE QUALITY CONTROL AND TESTS

- A. Provide shop testing in accordance with SJI standards.

PART 3 EXECUTION

EXAMINATION

- A. Coordination: Verification of existing conditions prior to beginning fabrication work.
- B. Production prior to approval of shop drawings shall be at contractor's risk.

ERECTION

- A. Erect and connect joists to supports.
- B. Allow for erection loads. Provide sufficient temporary bracing to maintain framing safe, plumb, and in true alignment. Strictly follow all OSHA regulations for job safety.
- C. Install, field weld and/or bolt joist seats to supports as erection progresses.
- D. Position and field weld joist bottom chord extensions as erection progresses.
- E. Frame roof openings greater than 12 x 12 inches with supplementary framing.
- F. Do not permit erection of decking until completion of installation of permanent bridging and bracing.
- G. Do not field cut or alter structural members without approval of joist manufacturer.
- H. All joist top chord extensions at ridges and eaves shall be brought into close alignment and

securely field welded to the continuous ridge and eave angles or plates to give true and straight line to ridges and eaves.

- I. After erection, prime welds, abrasions on shop primed joists.
- L. After erection, clean and prime paint welds, abrasions, and surfaces where shop primer has been disturbed, deteriorated, corroded, rusted, or damaged. Remove all surface contaminants, including soiled surfaces spoiled during laydown.

ERECTION TOLERANCES

- A. Maximum Variation From Plumb: 1/4 inch.
- B. Maximum Offset From True Alignment: 1/4 inch.

FIELD QUALITY CONTROL

- A. Field inspection will be performed by the Architect. Additional inspection of materials and connections shall be performed by an independent testing laboratory at the direction of the Architect. Payment for the testing laboratory services will be paid by the contractor out of the testing allowance.

END OF SECTION

RELATED DOCUMENTS:

Drawings and general provisions of Contract, including General and Supplementary Conditions and Division-1 Specification sections, apply to work of this section.

PART I: GENERAL

SECTION INCLUDES

- A. Steel roof deck and accessories.
- B. Formed steel ridge strips, eave strips, valley strips, fasteners, and sound attenuation strips for acoustical deck flute filler.

REFERENCES

- A. ASTM A36/A36M — Structural Steel.
- B. ASTM A1008/A1008M — Primed Sheet Steel, Cold—Rolled Sheet, Carbon, Structural Quality with minimum yield strength of 33 ksi.
- C. ASTM A653/A653M — Galvanized Sheet Steel, Cold—Rolled Sheet, Carbon, Structural Quality with minimum yield strength of 33 ksi.
- D. AWS D1.1 — Structural Welding Code.
- E. FM — Roof Assembly Classifications.
- F. SDI (Steel Deck Institute) — Design Manual for Composite Decks, Form Decks, Roof Decks, Cellular Metal Floor Deck with Electrical Distribution.
- G. SSPC (Steel Structures Painting Council) — Painting Manual.
- H. UL — Fire Resistance Directory.
- I. Warnock Hersey — Certification Listings.

PERFORMANCE REQUIREMENTS

- A. Design metal deck in accordance with SDI Design Manual.
- B. Deck units shall be laid out in a minimum three span condition.

SUBMITTALS FOR REVIEW

- A. Shop Drawings: Indicate deck plan, support locations, projections, openings, pertinent details, fastening patterns, and accessories with fastening patterns.
- B. Product Data: Provide deck profile characteristics and dimensions, structural properties, finishes, and fasteners for side laps.

SUBMITTALS FOR INFORMATION

- A. Certificates: Certify that Products meet or exceed specified requirements.
- B. Submit manufacturer's installation instructions.

- C. Welders Certificates: Certify welders employed on the Work, verifying AWS qualification within the previous 12 months.

QUALITY ASSURANCE

- A. Manufacturer: Company specializing furnishing material under this specification for a minimum of five years.
- B. Installer: Company specializing in performing the work of this Section with minimum five years experience.
- C. Design deck layout, spans, fastening, joints, under direct supervision of a Professional Structural Engineer experienced in design of this work and licensed in the State of North Carolina.

DELIVERY, STORAGE, AND HANDLING

- A. Material and Equipment: Transport, handle, store, and protect products from damage.
- B. Cut plastic wrap to encourage ventilation.
- C. Store deck and accessories on dry wood sleepers; slope for positive drainage.
- D. Store acoustical metal deck indoors to prevent rusting of the punched deck flutes. Store sound attenuation strips when required in sealed packages indoors out of the weather.

PART 2 PRODUCTS

MATERIALS

- A. Manufacturers:
 - 1. Vulcraft 1 ½" deep type 1.5 B, 22 gage with 36 " cover. Vulcraft 3" deep type N, 22 gage with 24" cover. Regular and Acoustical Deck units.
 - 2. Wheeling 1 ½" type B, 22 gage with 36" cover. Wheeling 3" deep type N, 22 gage with 24" cover. Regular and Acoustical Deck units.
 - 3. United Steel Deck 1 ½" type B, 22 gage with 36" cover. United 3" deep type N, 22 gage with 24" cover. Regular and Acoustical Deck units.
- B. Sheet Coating: 1 ½" type B regular and 3" type N shall be primed. Roof deck primer where cementitious spray-on fireproofing will be applied shall be certified to be compatible with the fireproofing and UL assemblies.
- C. Sheet Steel: ASTM A653/653M, A1008/A1008M with minimum yield strength 33 ksi.
- D. Welding Materials: AWS D1.1.
- E. Shop and Touch Up Primer: SSPC 15, Type 1, grey oxide for primed deck, certified as compatible with the fireproofing and UL assemblies.

ACCESSORIES

- A. Ridge Strips, Valley Strips, Eave Strips, sound attenuation strips for acoustical deck flute fills: Fabricated of metal of same type, gage and finish as deck.

PART 3 EXECUTION

EXAMINATION

- A. Coordination: Verification of existing conditions prior to beginning work.
- B. Fabrication prior to approval of shop drawings shall be entirely at the risk of the contractor.

INSTALLATION

- A. Erect metal deck in accordance with SDI Manual and manufacturer's instructions. Deck units shall be erected in a minimum three span condition unless otherwise noted on drawings.
- B. Bear deck on steel supports with 2 1/2 inch minimum bearing. Align deck units in true straight lines. Allow for minimum 3" end laps.
- C. Fasten deck to steel support members at ends and intermediate supports with 3/4" diameter fusion puddle welds at 12 inches oc maximum. Weld spacing shall be enhanced to 6" centers within 12 feet of ridges, gable ends, and eaves.
- D. Weld in accordance with AWS D1.1.
- E. Mechanically fasten side laps at 18 inches oc maximum with #12 tek screws.
- F. Place formed steel ridge strips, eave strips, valley strips in position and mechanically attach at 6" oc.
- G. Immediately after welding deck and other metal components in position, coat welds, burned areas, and damaged surface coating, with touch up zinc rich prime paint.

END OF SECTION

RELATED DOCUMENTS:

Drawings and general provisions of Contract, including General and Supplementary Conditions and Division-1 Specification sections, apply to work of this section.

PART 1: GENERAL

SECTION INCLUDES

- A. Steel floor deck and accessories.
- B. Formed steel deck end and edge forms to contain wet concrete.

REFERENCES

- A. ASTM A36/A36M - Structural Steel.
- B. ASTM A108 - Steel Bars, Carbon, Cold-Finished, Standard Quality.
- C. ASTM A653/(A653M) - Steel Sheet, Zinc-Coated (Galvanized) by the Hot-Dip Process, Structural Quality.
- D. ASTM A525 - Steel Sheet, Zinc-Coated, Galvanized by the Hot-Dip Process.
- E. ASTM A611 - Steel, Cold-Rolled Sheet, Carbon, Structural.
- F. AWS D1.1 - Structural Welding Code.
- G. FM - Floor Assembly Classifications.
- H. SDI (Steel Deck Institute) - Design Manual for Composite Decks, Form Decks, Roof Decks, Cellular Metal Floor Deck with Electrical Distribution.
- I. SSPC (Steel Structures Painting Council) - Painting Manual.
- J. UL - Fire Resistance Directory.
- K. Warnock Hersey - Certification Listings.

PERFORMANCE REQUIREMENTS

- A. Metal deck in accordance with SDI Design Manual.

SUBMITTALS FOR REVIEW

- A. Shop Drawings: Indicate deck erection piece marks on deck plan, support locations, projections, openings, welding pattern and side lap connection details and all pertinent details, and accessories.
- B. Product Data: Provide deck profile characteristics and dimensions, structural properties, and finishes.

SUBMITTALS FOR INFORMATION

- A. Certificates: Certify that Products meet or exceed specified requirements.

- B. Submit manufacturer's installation instructions.
- C. Welders Certificates: Certify welders employed on the Work, verifying AWS qualification within the previous 12 months.

QUALITY ASSURANCE

- A. Manufacturer and Installer: Companies specializing in performing the work of this Section with minimum five years documented experience.

DELIVERY, STORAGE, AND HANDLING

- A. Off load and handle deck in suitable manner so as not to damage deck units.
- B. Store deck on dry wood sleepers. Slope decking for positive drainage.
- C. Protect deck from damage and form accumulation of dust and debris.

PART 2 PRODUCTS

MATERIALS

- A. Deck units shall be 3" deep, 16 gage, galvanized, Type 3 VLI composite deck units as manufactured by Vulcraft products or approved equal.
- B. Sheet Steel: ASTM A653/653M Structural Quality; with G60 galvanized coating conforming to ASTM A653/653M.
- C. Welding Materials: AWS D1.1.
- D. Touch-Up Primer for Galvanized Surfaces: SSPC 20 Type I - Inorganic.

ACCESSORIES

- A. Flute Closures at ends of deck runs or change in deck direction.
- B. Provide column and beam closure plates and other closure plates as required to prevent fresh concrete leakage. Provide necessary miscellaneous framing supports around columns or other floor penetrations where required to achieve complete first class job.

FABRICATION

- A. Composite Metal Floor Deck Units shall be manufactured in accordance with SDI requirements.
- B. Related Deck Accessories: Metal closure strips, wet concrete stops, cover plates, of profile and size as required.

PART 3 EXECUTION

EXAMINATION

- A. Verification of existing conditions prior to beginning work is required.

INSTALLATION

- A. Erect metal deck in accordance with SDI Manual.
- B. Bear deck on masonry or concrete support surfaces with 3 inch minimum bearing. Align deck units to be true and straight.
- C. Bear deck on steel supports with 2 1/2 inch minimum bearing. Align deck units to be true and straight.
- D. Fasten deck units to steel support members at ends and intermediate supports with fusion welds through deck with one 3/4" diameter puddle weld. Weld in accordance with AWS D1.1.
- E. Mechanically fasten male/female side laps with TEK screws at 18 inches oc maximum. Screws to be #12 self drilling self tapping.
- G. Install sheet steel closures to close openings between deck and walls, columns, and other openings.
- H. Exercise proper care so as not to burn holes in deck and/or notch steel beam supports during the deck welding operations. Damaged deck and/or steel supports shall be removed and replaced at no additional cost to owner when directed by the Engineer.
- I. Immediately after welding deck and other metal components in position, coat welds, burned areas, and damaged surface coating, with touch-up cold galvanizing prime paint.
- J. Provide temporary shoring at mid span prior to placing concrete where recommended by deck supplier or where deck span exceeds 10'-6". Keep shoring 1/4" below deck to allow deck to "settle" down on shoring members when shoring is used.
- K. Plan placement of concrete sequence so that the weight of the fresh concrete is placed on the top most sheet in the male female side lap first to prevent excess concrete leakage.
- L. Avoid "piling" up fresh concrete on deck. Keep maximum fresh concrete thickness as close to final thickness as possible while placing concrete to avoid damage to deck due to excessive deck deflection.

END OF SECTION

RELATED DOCUMENTS:

Drawings and general provisions of Contract, including General and Supplementary Conditions and Division-1 Specification sections, apply to work of this section.

PART 1: GENERAL

1.1 SECTION INCLUDES

- A. Cold-formed structural metal stud framing at exterior and interior wall locations.
- B. Cold-formed structural metal stud framing for hand railing system at equipment platform locations.
- C. Framing accessories

1.2 REFERENCES

- A. ASTM A36 Standard Specification for Carbon Structural Steel.
- B. ASTM A123 Zinc (Hot—Dip Galvanized) Coatings on Iron and Steel Products.
- C. ASTM A1003 Standard Specification for Steel Sheet, Carbon, Metallic and Nonmetallic-Coated for Cold-Formed Framing Members.
- D. ASTM A525 General Requirements for Steel Sheet, Zinc—Coated (Galvanized) by the Hot—Dip Process.
- E. ASTM A591 Steel Sheet, Cold—Rolled, Electrolytic Zinc—Coated.
- F. ASTM C645 Non-Load (Axial) Bearing Steel Studs, Runners (Track) and Rigid Furring Channels for Screw Application of Gypsum Board.
- G. ASTM C754 Installation of Steel Framing Members to Receive Screw—Attached Gypsum Wallboard, Backing Board, or Water—Resistant Backing Board.
- H. ASTM C1513 Standard Specification for Steel Tapping Screws for Cold-Formed Steel Framing Connections.
- I. COSP Specification for the Design of Cold-Formed Steel Structural Members, Code of Standard Practice.
- J. GA 203 Installation of Screw Type Steel Framing Members to Receive Gypsum Board.
- K. Metal Framing Manufacturers Association (MFMA) Guidelines for the Use of Metal Framing.
- L. SSPC (Steel Structures Painting Council) Steel Structures Painting Manual.

1.3 SYSTEM DESCRIPTION

- A. Metal stud framing system for exterior walls shall be 6" or 8" x 68 mil minimum structural studs, as noted on Drawings, as manufactured by Marino\Ware, Dietrich, Unimast, Clark Metal Framing Systems or approved equal. Refer to Drawings for metal stud sizes and thickness.
- B. Refer to Drawings for interior metal stud sizes and gauges.
- C. Refer to Drawings for equipment platform and mezzanine metal stud handrailing system sizes and gauges.
- D. Design and size connection components to withstand dead and live loads caused by pressure and suction of wind acting normal to plane of wall as calculated in accordance with the current North Carolina State Building Code wind loading requirements.
- E. Maximum Allowable Deflection: 1/600 span.
- F. System to accommodate construction tolerances, deflection of building structural members, and clearances of intended openings.

- G. Wall studs shall align in straight and true lines.

1.4 SUBMITTALS

- A. Shop Drawings: Submit shop drawings to indicate plans, elevations, prefabricated work, component details, stud layout, framed openings, anchorage to structure, bracing, connection details, type and location of fasteners, weld lengths and locations, and accessories and finishes, or items required of other related work.

Show and describe method for securing studs to tracks, splicing, and for blocking and reinforcement to framing connections.

- B. Product Data: Provide manufacturer's product data and technical data sheets describing standard framing member materials and finish, product criteria, load charts, limitations.
- C. Manufacturer's Installation Instructions: Indicate special procedures, perimeter conditions requiring special attention.
- D. Delegated Design Submittals: Submit structural calculations as follows:
 - a. Structural calculations for connections and attachments, prepared by manufacturer for approval, sealed by a professional engineer registered in the State in which the project is located.
 - b. Description of design criteria.
 - c. Selection of framing connection requirements.
 - d. Verification of attachments to structure and adjacent framing components.
- E. Welder's current certifications for light gauge metal framing.

1.5 QUALITY ASSURANCE

- A. Perform Work in accordance with MFMA and ASTM C754.

1.6 QUALIFICATIONS

- A. Manufacturer:
 - a. Having [5] years of experience manufacturing components similar to or exceeding requirements of project.
 - b. Having sufficient capacity to produce and deliver required materials without causing delay in work.
- B. Manufacturer's Structural Engineer:
 - a. Professional engineer registered in the state in which the project is located.
 - b. Having a minimum of five years of experience with projects of similar scope.
- C. Installer: Acceptable to the manufacturer, experienced in performing the work of this section with minimum five years documented experience, and specialized in installation of work similar to that required for this project.

D. Welders: Certified by the AWS within the previous 12 months.

1.7 COORDINATION

A. Coordinate with all trades the placement of components within the stud framing system to provide a totally sound and complete system installation ready to receive sheathing and wallboard.

PART 2: PRODUCTS

2.1 STUD FRAMING MATERIALS

A. Studs: ASTM A525, ASTM A591, cold rolled steel, channel shaped, punched for utility access

1. Depth: 8", 6", 3 5/8", and as shown on the drawings.
2. Thickness: 68 mil minimum at 8" and 6" studs and 33 mil minimum 3 5/8" studs.
3. Width minimum 1 5/8" with 1/2" stiffening return both flanges.

B. Runners: Of same material and thickness as studs unless otherwise noted.

C. Furring and Horizontal CRC Bracing Members: Of same material as studs; thickness to suit purpose.

D. Vertical Deflection Clips and Tracks: Manufacturer's standard clips and tracks, capable of accommodating upward and downward vertical displacement of primary structure through positive mechanical attachment to studs.

E. Fasteners: Stainless steel or zinc coated #12 pan head, self-drilling, self tapping screws.

F. Anchorage Devices: Powder actuated fasteners and screws as shown on drawings.

G. Touch Up Primer for Galvanized Surfaces: SSPC — Paint 20 Type I Inorganic.

2.2 JOIST FRAMING

A. Steel Floor and Ceiling Joists: Cold-formed steel joists, of web depths indicated on Drawings, as follows:

- a. Type as indicated on Drawings.
- b. Minimum Base Metal Thickness: As indicated on the Drawings.
- c. Section Properties: As indicated on the Drawings.

B. Steel Joist Track: Cold-formed steel joist track, of web depths indicated, unpunched, with unstiffened flanges. Type as indicated on the Drawings. Minimum Base Metal Thickness: Match steel joists. Flange Width 1 1/4 inches, minimum.

2.3 ACCESSORIES

A. Framing Connectors:

- A. Type: Steel-framing accessories fabricated from steel sheet, ASTM A1003/A1003M, Structural Grade, Type H, metallic coated, of same grade and coating weight used for framing members.
- B. Provide accessories of manufacturer's standard thickness and configuration, unless otherwise indicated, as follows:
 - 1. Web stiffeners, solid blocking, utility angles, joist hangers, gusset plates, rigid clips, breakaway clips.
- C. Anchors, Clips and Fasteners
 - 1. Steel Shapes and Clips: ASTM A36/A36M and zinc coated by hot-dip process according to ASTM A123/A123M.
 - 2. Cold-formed Steel Connections: ASTM A653/A653M, zinc coated by hot-dip process according to ASTM A123/A123M.
 - 3. Expansion Anchors: Fabricated from corrosion-resistant materials, with capability to sustain, without failure, a load equal to 5 times design load, as determined by testing per ASTM E488.
 - 4. Powder-actuated Anchors: Fastener system of type suitable for application indicated, fabricated from corrosion resistant materials, with capability to sustain, without failure, a load equal to 10 times design load, as determined by testing per ASTM E1190 and as indicated on the drawings.
 - 5. Mechanical Fasteners: ASTM C1513, corrosion-resistant-coated, self-drilling, self-tapping steel drill screws.
 - 6. Welding Electrodes: Comply with AWS standards.
 - 7. Galvanizing Repair Paint: SSPC-Paint 20 or DOD-P-21035.
 - 8. Shims: Load bearing, high-density multimonomer plastic, non-leaching.
 - 9. Sealer Gaskets: Closed-cell neoprene foam, 1/4 inch (6.4 mm) thick, selected from manufacturer's standard widths to match width of bottom track or rim track members.

2.4 FABRICATION

- A. Fabricate cold-formed metal framing and accessories assemblies of framed sections to sizes and profiles required; with framing members fitted, plumb, square, and true to line, reinforced, and with connections securely fastened, and braced to suit design requirements, in accordance with referenced specification standards, and manufacturer's written instructions, and requirements in this Section.
- B. Fit and assemble in largest practical sections for delivery to site, ready for installation.
- C. Studs shall bear tightly against the top and bottom tracks.
- D. Fabricate framing assemblies using jigs or templates.
- E. Cut framing members by sawing or shearing; do not torch cut.

- F. Fasten cold-formed metal framing members by welds, screw fasteners, clinch fasteners or rivets as standard with fabricator. Do not wire-tie framing members.
 - a. Comply with AWS D1.3 requirements and procedures for welding, appearance and quality of welds, and methods used in correcting welding work.
 - b. Locate mechanical fasteners and install according to Shop Drawings, with screw penetrating joined members by not less than three exposed screw threads.
 - c. Fasten other materials to cold-formed metal framing by welding, bolting, or screw fastening, according to Shop Drawings.

2.5 FINISHES

- A. Studs: Galvanize to G60 coating class (minimum) or as indicated on Drawings.
- B. Tracks and Headers: Galvanize to G60 coating class (minimum) or as indicated on Drawings.
- C. Accessories: Same finish as framing members.

PART 3: EXECUTION

3.1 EXAMINATION

- A. Verify that conditions are ready to receive work.
- B. Verify that rough-in utilities are in proper location, and coordinated with framing.

3.2 ERECTION

- A. General:
 - 1. Erect in accordance with ASTM C1007 and manufacturer's installation instructions.
 - 2. Field Welding: Per AWS D1.3, and the following:
 - a. Stud-to-Track Connections: 1/2 inch (13 mm) fillet weld, full length of inside flange dimension, inside each flange of stud onto track web.
 - b. Other Connections: Flat, plug, butt or seam.
 - c. Minimum Steel Thickness for Welded Connections: 18 gauge.
 - d. Field Fastening: Minimum of 2 self-tapping metal screws per connection, unless otherwise indicated.
- B. Wall Systems:
 - 1. Align and secure top and bottom runners.
 - 2. Fit runners under and above openings; secure intermediate studs to same spacing as wall studs.
 - 3. Install studs vertically uniformly at the spacings shown on the drawings.

4. Align stud web openings horizontally.
 5. Secure studs to tracks using screws or welding.
 6. Stud splicing not permissible.
 7. Fabricate corners using a minimum of three studs.
 8. Minimum double stud at wall openings, door and window jambs, not more than 2 inches from each side of openings. Refer to drawings for additional jamb and head conditions.
 9. Brace stud framing system rigid.
 10. Coordinate erection of studs with requirements of doorframes, window frames, and; install supports and attachments.
 11. Coordinate installation of wood bucks, anchors, and wood blocking with electrical and mechanical work to be placed within or behind stud framing.
 12. Blocking: Secure wood blocking to studs. Secure steel channels to studs. Install blocking for support of plumbing fixtures, toilet partitions, wall cabinets, toilet accessories, hardware, etc. as required by Architect.
 13. Coordinate placement of insulation in stud spaces made inaccessible after stud framing erection.
 14. Fabricate and install headers at openings as indicated on Drawings.
 15. All multiple members shall be stitch welded together with 1" seam welds spaced at 16" oc maximum both sides of members to form a totally composite member. Multiple members in composite units shall not be spliced.
 16. All connections not shown on the drawings shall be designed by the supplier to support the imposed loads.
 17. Provide continuous 2" x 43 mil horizontal strap bridging at 48" maximum intervals on both flanges. Install with 1 screw per stud. Provide solid blocking using a piece of metal stud between studs at each end of bridging run and at 12' oc maximum. Terminate bridging at wall openings with solid blocking bridging as required.
 18. Place one stud tightly against each side of the tubular steel columns in line with the wall. Align the face of stud flush with face of tubular columns for smooth finish application for dry wall and sheathing. Fasten stud to column with powder actuated fasteners spaced at 16" oc.
 19. Touch-up field welds and damaged galvanized surfaces with primer.
- C. Steel Joists:
1. Locate joist end bearing directly over load bearing studs or provide approved load-distributing member to top of stud track.
 2. Provide web stiffeners at reaction points where indicated in drawings.
 3. Provide joist bridging as shown in drawings.
 4. Provide end blocking where joist ends are not otherwise restrained from rotation.

5. Place joists at maximum 12 inches on center and not more than 2 inches from abutting walls. Connect joists to supports using mechanical fastener method.
6. Touch-up field welds and damaged galvanized surfaces with primer.

D. Metal Stud Handrailing System:

1. Frame metal stud handrailing at equipment platforms / mezzanines in accordance with Drawings.

3.3 ERECTION TOLERANCES

- A. Maximum Variation From True Position: 1/4 inch.
- B. Maximum Variation of any Member from Plane: 1/4 inch.
- C. Maximum Variation From Plumb: 1/4 inch in 10' height.

END OF SECTION

RELATED DOCUMENTS:

Drawings and general provisions of Contract, including General and Supplementary Conditions and Division-1 Specification sections, apply to work of this section.

PART 1: GENERAL

DESCRIPTION OF WORK:

Work of this Section shall consist of all labor and materials required to provide all miscellaneous fabricated metal items scheduled on Drawings and specified in this Section.

Miscellaneous metal items for which drawing information is fully descriptive that are not necessarily named herein, shall be provided as shown and as required, providing complete assemblies.

INDUSTRY STANDARDS:

For listing of names of industry standard agencies mentioned by abbreviation in this Section refer to Section 01068.

QUALITY ASSURANCE:

Manufacturers:

Standard: For purposes of designating type and quality for work under this Section, Drawings and Specifications are based on products manufactured or furnished by Manufacturers listed for each item.

SUBMITTALS:

Shop Drawings: Submit shop drawings in quadruplicate to Architect in accordance with GENERAL CONDITIONS for approval of all fabricated miscellaneous items. Shop drawings shall indicate following: fabrication, assembly and erection details, sizes of all members, fastenings, supports, and anchors; patterns; clearances, and all necessary connection to work of other trades.

Catalog Cuts: For standard manufactured items, catalog cuts may be submitted as specified in GENERAL CONDITIONS, providing all technical performance characteristics and other pertinent information are given.

PRODUCT HANDLING:

Handling and Storage: Handle all materials carefully to prevent damage and store at site above ground in covered, dry locations.

Replacement: Damaged items that cannot be restored to like-new conditions shall be removed and replaced at no additional cost to Owner.

PART 2: PRODUCTS

BASIC MATERIALS:

Structural Shapes: ASTM A 36/A572 Dual Certified.

Steel Pipes: ASTM A 72 welded wrought iron pipe, standard weight, Schedule 40.

Steel Pipes: ASTM A123 - Zinc (Hot Dipped Galvanized) Coatings on Iron and Steel Products

Steel Tubing: ASTM A 500, Grade B.

Cast Iron: ASTM A 48j, Class 30, with minimum tensile strength of 30,000 psi.

Zinc-coated iron or Steel Sheets: ASTM A 446.

Cold-rolled Carbon Steel Sheets: ASTM A 366-66.

Exterior Lintels: ASTM A123 - Zinc (Hot Dipped Galvanized) Coatings on Iron and Steel Products

Metal Bar Grating: NAAMM A202.1 Metal Bar Grating Manual

Stainless Steel Sheet: Type #304

FABRICATION:

Measurements: Verify all measurements and take all field measurements necessary before fabrication.

Fasteners: Exposed fastenings shall be compatible materials, shall generally match in color and finish, and shall harmonize with material to which fastenings are applied. Permanent connections shall be riveted, welded or bolted. Exposed welds shall be ground smooth and flush.

Components: Include materials and parts necessary to complete each item properly, even though such work may not definitely be shown or specified.

Provide and install miscellaneous bolts and anchors, supports, braces, and connections necessary for completion of work.

Drill or punch holes for bolts and screws. Poor matching of holes will be rejected. Conceal fastenings where practicable.

Painting and Protective Coating:

All ferrous metal, except stainless steel and galvanized surfaces, shall be properly cleaned and given one shop coat of red lead or zinc chromate primer.

Anchors built into masonry shall be coated with asphalt paint unless specified to be galvanized. Metal work to be encased in concrete shall be left unpainted unless specified or noted otherwise.

Where hot-dip galvanized or zinc-coated metal is specified or shown, it shall not be shop-primed unless specifically required otherwise for paint finish, which shall require bonderized or paint-grip primer. Recoat at all field welds and grindings, and where initial galvanized coating has been removed or deteriorated.

Galvanizing:

Hot-dip galvanizing or zinc coatings applied on products fabricated from rolled, pressed and forged steel shapes, plates, pipes, bars and strips shall comply with ASTM A 123-68.

Unless otherwise noted, all exposed exterior structural steel members and steel framing shall be hot-dipped galvanized after fabrication to comply with ASTM A123 G60 standards, including but not limited to: steel pipe, structural steel columns (tubes or wide flanged), beams (tubes or wide flanged), steel angle framing, connections. Reference 09900 Paint for paint primer and topcoats requirements.

Lintels in exterior walls shall be hot dip galvanized to ASTM A123 G60 standards after fabrication. Reference 09900 Paint for paint primer and topcoats requirements.

Exterior handrails shall be hot dip galvanized to ASTM A123 G90 standards, not less than .90 oz/square foot, after fabrication.

Exterior steel stair treads, unless otherwise noted, shall be hot dip galvanized to ASTM A123 G90 standards, not less than .90 oz/square foot, after fabrication.

Steel bar grating, unless otherwise indicated shall be hot dip galvanized to ASTM A123 G90 standards, not less than .90 oz/square foot, after fabrication.

MISCELLANEOUS ITEMS:

Supplementary Structural Steel: All structural framing incorporated in building design and detailed on Architectural Drawings, but not shown on Structural Steel Drawings, shall be furnished as part of miscellaneous metal work.

Miscellaneous Lintels, Shelf Angles, Beams and Plates, Brackets: Provide miscellaneous lintels and shelf angles, beams, plates, and brackets as indicated.

Lintels shall have 8" bearings at each end unless shown otherwise.

Weld or bolt members together where so indicated, to form complete composite assembly. Set beams on plates as indicated.

Where shelf angles are attached to concrete with bolts and adjustable inserts, provide slotted holes of proper size and spacing in vertical leg of shelf angles.

Miscellaneous Fasteners: Furnish all bolts, nuts, anchor bolts, plates, anchors, ties, clamps, hangers, nails, spikes, screws, straps, toggle and expansion bolts, and other items of rough hardware of sufficient size and number to tie together various parts of building and secure all of its parts in place. Such miscellaneous items shall be of same material as metals they contact.

Supports, Bracing:

Furnish and install all bracing and suspension type supports, fastened to structure, for following and additional conditions, as may be required.

1. Exterior soffits
2. Head of exterior doors and window wall

Steel Bar Grating: Provide galvanized steel bar gratings, cat-walk type, where indicated on Drawings, in accordance with ASTM A36/A36M and NAAMM A202.1 Welded. Steel bar gratings shall be hot dip galvanized to ASTM A123 G90 and ASTM A525 G90 standards. Top surface shall be serrated. Provide complete assemblies, that include all required accessories in matching galvanized materials; to include but not limited to: Fasteners and J-hooks, perimeter closures, and edge banding. Anchor in place by welding, and weld joints of intersecting metal sections. Touch up all cuts and welds with SSPC 20 Type I Inorganic, zinc rich primer.

Handrails: Provide pipe handrails as detailed, fabricated from 1-1/2 O.D. pipe. Weld all joints and grind smooth. Fabricate entire assembly carefully in accordance with details. After installation, use wire brush, sand blast, or otherwise treat to provide completely smooth surface for application of paint. Interior wall

handrails consist of straight sections of black steel pipe, mounted on wall brackets. Install brackets with approved anchoring device. Close ends with molded end closures.

All exterior handrails shall be G-90 hot dipped galvanized. All welds and grindings to be recoated on site with a field applied zinc galvanizing coating to match.

Ladders: Where indicated, vertical wall mounted interior ladders shall be 20" wide, fabricated with 3/8"x 1-1/2" hot-rolled rails and 3/4" round steel rungs extending through rails with connection welds, provided at all roof hatch locations. Space rungs 12" o.c. Anchor ladders at bottom and top. Brackets shall be of same size as side rails and of such length as to hold ladder 7" away from wall.

Exterior ladders shall be G-60 hot-dipped galvanized.

Fold-out Escape Egress Ladder: Provide prefabricated extruded aluminum and stainless steel fold-out escape egress ladder on utility platforms where indicated on drawings, rated for 1000 lbs., 6060-T6 high-grade aluminum, pull out release pin, see Drawings. "MODUM Fire Escape Ladder", by Modum International of Illinois Accessories include egress ladder signage, acrylic sign panels as indicated on drawings, removable chain in safety yellow.

Mount and anchor to (4) member built up metal stud post at platform level and to wall surface below platform. Adjacent ceilings to be installed in breakaway fashion to allow complete fold-out operation.

PART 3: EXECUTION

WORKMANSHIP:

Ferrous metal surfaces shall be clean and free from mill scale, flake rust and rust pitting; well formed and finished to shape and size, with sharp lines and angles and smooth surfaces.

Castings shall be of uniform quality, free from blow-holes, porosity, hard spots, shrinkage distortion or other defects. Castings shall be smooth and well cleaned by shot-blasting or other approved method. Covers subject to street or foot traffic shall have machined horizontal bearing surfaces. Provide machined bearing or contact surfaces for other joints where indicated or required.

COORDINATION: At proper time, deliver and set in place items of metal work to be built into adjoining construction.

PAINTING: Finish painting of items not factory painted shall be as specified in Section 09900.

STEEL FRAMED STAIRS:

GENERAL: Construct stairs to conform to sizes and arrangements shown; joint pieces together by welding unless otherwise indicated. Provide complete stair assemblies including metal framing, hangers, columns, railings, newels, balusters, struts, clips, brackets, bearing plates, connections and other components necessary for the support of stairs and platforms and as required to anchor and contain the stairs on the supporting structure and within locations indicated. Certify the stair design is complete with sealed shop drawings bearing the seal of an N. C. Registered Engineer indicating capacity to support 100 p.s.f. uniform live load or 300 pound concentrated load as required by code.

EXTERIOR STEEL FRAMED STAIRS: Exterior steel framed stairs, ships ladders, ladders shall be finished in ASTM A123 G60 hot dip galvanized. Treads shall be G90 hot dip galvanized.

STAIR FRAMING: Fabricate stringers of structural steel channels, or plates, or a combination thereof, as shown. Provide closures for exposed ends of stringers. Construct platforms of structural steel channel

headers and miscellaneous framing members as shown. Bolt or weld headers to strings and newels and framing members to strings and headers; fabricate and join so that bolts, if used, do not appear on finish surfaces.

METAL PAN RISERS, SUBTREADS, AND SUBPLATFORMS: Shape metal pans for risers and subtreads to conform to configuration shown. Provide minimum 12 gage thickness of structural steel sheet for metal pans indicated but not less than that required to support total design loading.

Form metal pans of hot-rolled or cold-rolled carbon steel sheet, unless otherwise indicated.

Attach risers and subtreads to stringers by means of brackets made of steel angles or bars. Weld brackets to strings and attach metal pans to brackets by welding, riveting or bolting.

Provide subplatforms of configuration and construction indicated, or if not indicated, of same metal as risers and subtreads and in thickness required to support design loading. Attach sub platform to platform framing members with welds.

END OF SECTION

RELATED DOCUMENTS:

Drawings and general provisions of Contract, including General and Supplementary Conditions and Division-1 Specification sections, apply to work of this section.

PART 1: GENERAL

DESCRIPTION OF WORK:

Work of this Section shall be to provide expansion control joint covers as shown on Drawings and specified in this Section.

Building expansion joints with joint covers specified (walls, floors and ceilings) are required at all locations where enclosed connectors meet building units.

INDUSTRY STANDARDS:

For listing of names of industry standard agencies mentioned by abbreviation in this Section, refer to Section 01068.

QUALITY ASSURANCE:

Manufacturers:

Standard: For purpose of designating type and quality for work under this Section, Drawings and Specifications are based on products manufactured by the C/S Group Company. Other Manufacturers who can furnish products or systems of same materials specified and equal in all respects will also be acceptable, such as Architectural Art Mfg., Balco, Inc., and M M Systems.

SUBMITTALS:

Manufacturer's Data: Submit three (3) copies of folder containing complete Manufacturer's data and installation procedures for all products to be used in work of this Section.

Shop Drawings: Submit Shop Drawings in compliance with GENERAL CONDITIONS. These drawings shall be coordinated with adjacent work.

PRODUCT HANDLING:

Working Areas: Provide suitable areas for storage of materials and equipment.

Delivery: Deliver products to site in original sealed containers or packages bearing Manufacturer's name and brand designation.

PART 2: PRODUCTS

FLOOR JOINT COVERS: Balco, Inc. Model 75FPE-1 Series or C/S Group Model SJPW Series. Coordinate with finish floor material. Floor to floor units to be complete with extruded aluminum frames, center plates and cover plates extruded from 6063T5 alloy. Frames to be anchored to slab with 1/4" (6.25 mm) diameter expansion bolt anchors. Flexible vinyl expansion filler. Floor joints to be coordinated to provide alignment with wall and ceiling expansion joint covers. All aluminum surfaces in contact with masonry shall receive a shop coat of zinc chromate primer.

WALL JOINT COVERS: C/S Group Model ASM-100 or ASM-100 W/FB Series. Extruded aluminum cover plates and snap-lock anchor clips to be 6063-T52 alloy. Cover plate to be supplied with continuous duroflex seal. Snap-lock anchor shall be secured 24" O.C., complete with serrations to assure positive adjustable anchorage. Finish shall be satin clear anodize, prime coat for field painting, Medium , dark Bronze or Kynar 500 colors, to be selected by Architect to suit condition of use.

CEILING JOINT COVERS: C/S GROUP MODEL HC OR HCW. Cover shall be dual durometer P.V.C. The vertical legs shall be a rigid material for positive anchoring. The exposed bellows shall be a flexible P.V.C. to allow for expansion and contraction of the joint cover. Color to be white.

PART 3: EXECUTION

INSPECTION

Examine all surfaces to which products are scheduled to be installed. If unsatisfactory conditions exist, report to General Contractor and do not proceed with work until conditions have been satisfactorily corrected.

INSTALLATION

Install expansion joint covers at locations indicated on Architectural and / or Structural Drawings and at all locations where enclosed connectors meet building units, in accordance with Manufacturer's printed instructions and Shop Drawings, approved by Architect.

All installations shall be performed by capable workmen under direction of foreman fully qualified by experience in each respective field of installation work.

END OF SECTION

RELATED DOCUMENTS:

Drawings and general provisions of Contract, including General and Supplementary Conditions and Division-1 Specification sections, apply to work of this section.

PART 1: GENERAL

DESCRIPTION OF WORK:

Work of this Section shall consist of all labor and materials required to provide all rough carpentry work scheduled on Drawings and specified herein.

INDUSTRY STANDARDS:

For listing of names of industry standard agencies mentioned by abbreviation in this section refer to Section 01068.

CODE COMPLIANCE:

All framing to comply with the current edition of the Building Code having jurisdiction in North Carolina.

QUALITY ASSURANCE:

Manufacturers:

Standard: For purposes of designating type and quality of work under this Section, drawings and Specifications are based on products manufactured or furnished by Manufacturer listed for each product.

COORDINATION WITH OTHER TRADES: Coordinate locating of nailers, furring, grounds, and similar supports for other trades so that installation of finish work may be properly executed to fulfill design requirements.

MOISTURE CONTENT OF LUMBER: Maximum moisture content for lumber products shall be 19 percent on air dried stock, and 15 percent maximum on kiln-dried (KD) stock.

DRESSED LUMBER: Surface lumber four sides (S4S) unless specified otherwise for particular products.

DELIVERY AND STORAGE: As soon as materials are delivered to site, place under cover and protect properly from weather. Do not store or erect material in wet or damp portions of buildings or in areas where plastering or similar work is to be executed until such work has been completed and has become reasonably dry.

PART 2: PRODUCTS

FRAMING LUMBER

Various materials for framing shall be of sizes shown and shall conform to Grading Standards of SPIB. All framing material shall be #2 SYP.

Where indicated on the Drawings, provide FRT Fire Retardant Treated lumber.

PLYWOOD or ORIENTED STRAND BOARD MATERIALS: Softwood plywood or OSB sheathing shall conform to requirements of U. S. Product Standard PS 1-66, Construction and Industrial. All plywood or

OSB sheathing which has any edge or surface permanently exposed to weather shall be "EXTERIOR" type.

Where indicated on the Drawings, provide FRT Fire Retardant Treated plywood.

Where indicated on the Drawings, provide PT Preservative Treated plywood.

PRESERVATIVE TREATED WOOD PRODUCTS: Protective pressure treatment of lumber or products shall be .40 pcf retention of chromated copper arsenate as produced by Wolman, Osmose, Boliden or approved equal. Material shall be treatment grade marked, for ground contact, kiln dried not to exceed 19%, and all cut ends shall be coated with the same preservative, at job site during construction.

All lumber products in contact or fastened to concrete, concrete masonry or brick masonry to be preservative treated wood products.

FASTENING DEVICES: Anchors and fasteners for securing wood items, unless noted otherwise, shall meet following requirements:

Bolts:

- Bolts, nuts, studs and rivets shall conform to Federal Specifications FF-B-571a and FF-B-575, as applicable.
- Lag screws or lag bolts: Federal Specification FF-B-561b.
- Toggle Bolts: Federal Specification FF-B-588b.
- Screws: Federal Specification FF-S-111b.
- Nails and Staples: Federal Specification FF-N-105a.

All fastening devices used in exterior or concrete construction shall be hot-dip galvanized.

All fastening devices used in Fire Retardant Treated or Preservative Treated lumber and plywood to be corrosion resistant per manufacturer's recommendations.

Ground Anchorage: Wood plugs or nailing blocks are not acceptable for fastening grounds, furring, or blocking to concrete or masonry. Hardened steel nails, expansion screws, toggle-bolts, metal plugs, or metal inserts, as most appropriate for each type of masonry or concrete construction shall be used.

Explosive-Driven Fastenings: Explosive or powder-driven fastenings may be used only when approved by Architect.

PART 3: EXECUTION

GENERAL REQUIREMENTS FOR FRAMING AND BRACING:

Finish: Unless otherwise indicated, use S4S lumber for all framing members.

Size: Unless otherwise indicated, framing shall conform to nominal size requirements shown on Drawings.

Space framing on 16 inch centers, unless shown otherwise on Drawings.

Install required blocking, bracing, or other framing required for support of built-in equipment,

including casework.

INSTALLATION OF WOOD GROUNDS:

Location: Install permanent and temporary wood grounds as indicated for proper execution of work of all trades. Remove temporary grounds when no longer required.

Fastening: Except as otherwise required for special locations, form grounds of kiln-dried southern yellow pine, 1-1/2 inches wide, and of thickness to properly align related items of work. Securely fasten grounds into position by means of nails, brads, bolts, or other methods that will provide maximum results.

Coordination: Coordinate locations, sizes and fastenings of grounds with work of other trades. When grounds are to provide backing for fastening of grilles, fixtures, louvers, and similar items of work, exercise care in installation of grounds to provide for correct installation of those other items of work.

INSTALLATION OF WOOD BLOCKING:

Location: Install all wood blocking required to provide anchorage for other materials. Form to shapes and sizes as indicated or as may be required to accomplish particular installation. Form blocking of sizes shown or of minimum 2 inch thick nominal material.

At location of wall mounted equipment install 2"x 8" blocking unit between properly located studs at height indicated in Finish Hardware Schedule, or where indicated for wall mounted equipment. Install wood blocking behind all cabinets and toilet accessories as required.

Steel: Blocking in conjunction with steel work shall be bolted to steel with bolts, washers and nuts, countersunk where required.

Roofing: Form blocking in conjunction with gravel stops and built-up roofs to shapes as detailed. Anchor with countersunk bolts, washers and nuts.

Anchorage: Wedge, anchor and align blocking to provide rigid and secure installation of both blocking and other related work.

INSTALLATION OF WOOD FURRING:

Location: Provide all free-standing, suspended, solid-anchored, and other types of wood furring as required for receipt, alignment and complete installation of various types of finishing materials.

Spacing: Space furring members as required. Provide headers and other nailing members within furring framework. Install with faces true to line and plumb, using wood shims as necessary.

Fastening: Install furring into position by whatever means required to provide secure, rigid, and correct installation. When necessary, use nailing plugs, power-actuated anchors, toggle bolts, anchor bolts, washers and nuts, nails, and similar fastenings.

CLEANING UP: At completion, remove all excess materials and all debris resultant from operations of work of this Section. Leave entire work in neat, clean condition, satisfactory for receipt of other related items of work to be installed as part of work of other Sections.

END OF SECTION

RELATED DOCUMENTS:

Drawings and general provisions of Contract, including General and Supplementary Conditions and Division-1 Specification sections, apply to work of this section.

PART 1: GENERAL

DESCRIPTION OF WORK:

Work of this Section shall include furnishings all labor and materials required to provide all finish carpentry and millwork, as scheduled on Drawings and as specified herein.

Work Included This Section:

All finish carpentry, cabinetwork, and millwork, as identified on Drawings, which shall include, but not necessarily be limited to the following:

1. Cabinets (base and wall hung)
2. Interior wood trim and paneling.
3. Work Counters
4. Shelves and Slatwall
5. Hanging all wood doors as scheduled. Doors will be fabricated prefrit.

Furnish all millwork and cabinet work, deliver to building, assemble, level, secure to floors and/or walls, as shown on Drawings, equipment schedule, Specifications, and processed Shop Drawings.

INDUSTRY STANDARDS:

For listing of names of industry standard agencies mentioned by abbreviation in this section refer to Section 01068.

AWI Quality Standard: Comply with applicable requirements of "Architectural Woodwork Quality Standards" published by the Architectural Woodwork Institute (AWI), except as otherwise indicated.

QUALITY CONTROL:

Millwork Contractor shall be approved by Architect on basis of quality of work performed during at least 10 years of manufacturing, capability to meet requirements of these specifications, reputation of performing satisfactory work on time, and completion of at least three satisfactory installations of projects of comparable size.

SUBMITTALS:

Shop Drawings: Submit shop drawings in accordance with GENERAL CONDITIONS on all items fabricated for this Project. Shop Drawings shall locate all grounds, blocking, and other anchoring devices required to properly secure the work.

Do not fabricate millwork until final Shop Drawings have been processed by Architect. Reviewing and processing shop drawings by Architect does not relieve Contractor of checking and verifying job dimensions and conditions required by details on processed Shop Drawings and Contract Drawings.

Reviewing and processing shop drawings by Architect does not authorize changes. No changes will be made without explicit written authorization.

Samples: Submit samples of following items for approval by Architect prior to preparation of Shop Drawings and deliver to Project Site.

- Submit complete and current plastic laminate colors and patterns sample chain from Formica, that includes samples of all standard and premium textures and patterns options.
- Submit complete laminate colors/pattern/textures chains from Formica, Nevamar, and Wilsonart, chains from all three manufacturers, for Architect to select from.
- Submit complete and current colors and patterns sample chain of PVC edgeband.
- Cabinet door and drawer, showing constructions.
- Shelving Wood trim countertop and backsplash (plastic laminate clad)

PRODUCT HANDLING:

Delivery: Do not deliver millwork items to job site until building is sufficiently conditioned to prevent damage by moisture, dampness, excessive humidity, extreme dryness, extreme heat or cold.

Storage: Store millwork in enclosed areas having same temperature and humidity conditions as areas in which millwork will be installed.

Damaged Items: Remove from site immediately all items damaged due to improper handling or storage.

ENVIRONMENTAL CONDITIONS:

Building Conditions: Install millwork only when normal temperature and humidity conditions approximate interior conditions that will exist when building is occupied.

Glazing shall be in place, and all exterior openings closed. All concrete, plastering, and other wet work shall be completed and dry.

Heat and Ventilation shall be provided to maintain proper conditions before, during and after completion of installing casework.

FIELD MEASURING AND COORDINATION:

Before fabrication begins, inspect and field measure all areas to receive work, as follows:

Field measure areas where the work is to be installed.

Field coordinate with adjacent electrical and data outlet locations, and adjacent equipment locations, prior to rough-in of electrical devices.

PART 2: PRODUCTS

MATERIALS:

General: Except as otherwise indicated, comply with following requirements for architectural woodwork not specifically indicated as prefabricated or prefinished standard products.

Wood Moisture Content: Provide kiln-dried (KD) lumber with an average moisture content range of 9% to 13% for exterior work and 6% to 11% for interior work. Maintain temperature and relative humidity during fabrication, storage and finishing operations so that moisture content values for woodwork at time of installation do not exceed the following:

Interior Wood Finish: 8% - 11% for damp regions (as defined by AWI).

Interior Wood for Transparent Finish:

Solid Wood: Plain-sawn premium clear red oak.

Plywood: Plain sliced premium clear red oak.

Plastic Laminate: Comply with NEMA LD-3 for type (vertical and horizontal grades), thickness, color, pattern, finish and textures indicated for each application, or if not indicated, as selected by the Architect from the manufacturer's complete line of colors and patterns, and from the manufacturer's complete line of standard and premium textures options.

Manufacturer:

Standard: For purpose of designating type and quality for plastic laminate work under this Section, Drawings and Specifications are based on products manufactured by Formica.

The basis of design is Formica's complete line of plastic laminate colors and patterns, including all of Formica's complete line of standard and premium textures options.

Submit complete and current laminate color/patterns/textures sample chains from Formica, Nevamar, and Wilsonart, all three manufacturers, for Architect to choose from.

Provide exterior grade plywood or water-resistant resin impregnated composition board countertops at all locations with a sink. Use CD exterior grade veneer plywood, fabricated with water resistant glues and adhesives.

Quality Standards: For following types of architectural woodwork; comply with indicated standards as applicable:

Casework and Countertops: AWI Section 400.

Shelving: AWI Section 600.

Design and Construction Features: Comply with details shown for profile and construction of architectural woodwork; and, where not otherwise shown, comply with applicable Quality Standards, with alternate details as Fabricator's option.

Solid Surface Countertops and Benches: Where Corian Solid Surface countertops or benches are indicated on Drawings, provide 1/2" Corian or equal solid surfacing material. Architect to select from manufacturer's full range of colors and patterns.

Laminated Slatwall Paneling: Where indicated on Drawings, provide 3/4 inch thick medium density fiberboard paneling, laminated with high pressure laminate, grooved to receive standard-sized fixture mounting brackets for display. Color to be selected from panel manufacturer's standard options. Grooves shall be lined with powder coated extruded aluminum inserts, color selected by Architect.

Slatwall Display Accessories: Where indicated on Drawings, provide 4 rows of 12" deep x 3/4" thick melamine slatwall shelving, with all necessary shelf brackets, for complete shelving assemblies. Provide

(2) 25-count packs of assorted slatwall peg hooks; one pack with assorted 2", 4", 6" sizes, and one pack with assorted 8", 10", 12" sizes.

INTERIOR ARCHITECTURAL WOODWORK:

Wood Casework, Transparent Finish or Plastic Laminate Clad

AWI Section: 400

Grade: Custom, with book matching of adjoining leafs with transparent finish

Construction: Reveal Overlay.

CABINET HARDWARE AND ACCESSORY MATERIALS:

Hardware Standards: Except as otherwise indicated, comply with ANSI A 156.9 "American National Standard for Cabinet Hardware". Millwork Contractor to provide slides, dual hinges, catches, standards, brackets, locks, and pulls as shown and required.

Drawer and Door Pulls: Hafele No. 151.33.203, cast aluminum, brushed finish.

Catches: Heavy-duty roller ball catches.

Catches for Tall Cabinet Door Pairs: EPCO Heavy-Duty Elbow Catch, spring-loaded, in bright nickel finish, manufactured in solid brass, with slotted screw adjustment holes.

Locks for Tall Teachers Cabinets: Provide pin & tumbler master keyed cam locks, for each tall teacher cabinet, dull chrome finish.

Hinges: Reveal overlay, 5-knuckle, non-removable pin, institutional hospital type, brushed nickel finish, by Terry or Rockford Process Control, or equivalent.

Shelf Clips: Allen Field heavy-duty polycarbonate double pin shelf locking support, secures and supports 1" shelving.

Edge Band: 3mm PVC unless indicated otherwise, exposed or concealed.

Unless otherwise noted, all edges shall be banded with 3mm PVC, with all PVC edges eased with a radius.

Shelving Edge Band: Provide 3mm PVC edgebanding of shelves on front and rear edges only, with 1mm PVC edgebanding on remaining two side support edges.

Countertop Support Bracket: Wall mounted bracket, powder coated A-36 steel angle, 3/8" thick x 2.5" with beveled edges, with integral steel gusset. Mount with masonry expansion anchors at masonry support wall. Equivalent to model Front Mounting PLUS Brackets by Centerline Brackets.

Glass shall be Grade A, double strength, where scheduled.

Stainless steel sinks will be furnished and installed by Plumbing Contractor in countertop openings provided by Millwork Contractor.

PART 3: EXECUTION

INSPECTION OF SURFACES:

Inspection: Before installation begins, inspect all areas to receive work, as follows:

Field measuring areas where the work is to be installed.

For any deficiency which might prevent satisfactory installation of cabinetwork, millwork, or hanging wood doors, including coordination with adjacent electrical and data outlet, and adjacent equipment locations.

For presence and proper positioning of grounds and other anchoring devices built into work as required by approved millwork Shop Drawings.

Acceptance of Surfaces: Do not start fabrication or work until deficiencies of surfaces to receive work have been corrected. Beginning of installation in any area shall constitute acceptance of that area as satisfactory to receive this work, and shall constitute acknowledgement that all areas have been field measured, and all coordination with adjacent systems have been performed. Contractor shall be fully accountable for final results and workmanship specified herein.

INSTALLATION:

Cabinetwork:

Install all cabinetwork in place, level, plumb, and accurately scribed and secured to wall and/or floor, as shown on Shop Drawings approved by Architect.

Wall cabinets shall be fastened using 1/4" diameter lag bolts in lead shields with chrome finish washers @ 24" maximum spacing, minimum of 4 anchors per wall hung cabinet section, 2 anchors across top and 2 anchors across bottom.

Base cabinets shall be fastened using 1/4" diameter lag bolts in lead shields @ 24" maximum spacing, minimum of 4 anchors per cabinet section.

Installation shall be complete, including all trim and fillers required.

At completion of installation leave all cabinets clean and free of defects.

Wood Doors:

Hang all wood doors according to Door Schedule and Shop Drawings approved by Architect.

Leave each door neatly hung, swinging easily, and performing all functions intended by finish hardware schedule.

CLEANUP: At completion of all Finish Carpentry, Cabinetwork and Millwork installations clean up all areas in which work was performed and leave ready for installation of related work.

END OF SECTION

RELATED DOCUMENTS:

The general provisions of the Contract, including General and Supplementary Conditions, and General Requirements, and Division 1 specifications that apply to the work specified in this Section.

PART 1: GENERAL

DESCRIPTION OF WORK:

Work of this Section shall consist of furnishing all labor and materials required to insulate exterior CMU/brick cavity walls, exterior stud/brick cavity walls, interior stud walls, foundations, interior ceilings, and acoustical sound tubes all as shown on Drawings and as specified herein.

INDUSTRY STANDARDS:

For listing of names of industry standard agencies mentioned by abbreviation in this section refer to Section 01068.

QUALITY ASSURANCE:

Extent of insulation work is shown on drawings and indicated by provisions of this section.

Applications of insulation specified in this section include the following:

- Spray Applied Polyurethane Insulation
- Ceiling fiberglass blanket Insulation.
- Exterior Below Grade Waterproofing
- Sound Attenuation Batt Insulation (install at all interior metal stud / gypsum wallboard partitions, and where indicated on Drawings)

QUALITY ASSURANCE:

Thermal Conductivity: Thicknesses indicated are for thermal conductivity (k-value at 75 degrees F or 24 degrees C) specified for each material. Provide adjusted thicknesses as directed for equivalent use of material having a different thermal conductivity. Where insulation is identified by "R" value, provide thickness required to achieve indicated value.

SUBMITTALS:

Product Data: Submit manufacturer's product specifications and installation instructions for each type of insulation and vapor barrier material required.

PRODUCT HANDLING:

General Protection: Protect insulation from physical damage and from becoming wet, soiled, or covered with ice or snow. Comply with manufacturer's recommendations for handling, storage and protection during installation.

PART 2: PRODUCTS

SPRAY APPLIED POLYURETHANE INSULATION:

Provide labor, materials, and equipment necessary to two-component, self-adhering spray-apply using blowing agent HFC-245fa, closed-cell polyurethane foam (SPF) insulation, air seal and water repellent treatment for CMU/brick cavity walls and at interior side of exterior stud walls throughout the Project. Not required at CMU surfaces to receive EIFS finish.

Spray Polyurethane Foam Insulation shall be a seamless self-adhering spray-applied rigid polyurethane foam system, forming a membrane that seals CMU surfaces. Spray apply in liquid form, to form a seamless, thermal, moisture and air barrier and envelope across CMU to structural steel surfaces, and at wall-to-roof decking transition areas.

Application: Substrate to which insulation is applied must be clean, dry as confirmed by testing, and free of frost, ice, loose debris, or contaminants that will interfere with adhesion of the spray applied insulation.

Apply primers to surfaces where required by manufacturer's installation instructions. Spray apply to substrates when ambient air temperatures no less than 50 degrees F or as authorized by manufacturer, and when ambient humidity is within manufacturer's guideline ranges, and following all manufacturer's installation guidelines. Apply after the perimeter wall is in place, and rough-in plumbing and electrical penetrations inspections are completed.

Mask off all areas and surfaces to not to receive insulation. Upon completion, remove all overspray, and remove all masking materials. Shield the spray polyurethane foam from interior exposure with an approved thermal barrier.

Where damage occurs which violates the spray foam's air seal and moisture seal, repair as needed using specified spray polyurethane material or specified foam repair kit material.

Accessories:

- A. Foam Repair Kit and Materials: Provide as per manufacturer's standard products, provided by manufacturer or equivalent kits.
- B. Mineral Wool: Safing Mineral Wool Board, 4.0 lb./cu.ft. density, as manufactured by Rock Wool Manufacturing, or equivalent.
- C. Moisture Detection Paper (MDP) Strips: MDP Strips manufactured by NCFI Polyurethanes or equivalent.
- D. Liquid-Applied air barrier flashing, equivalent to Prosoco FastFlash, Carlisle Barrier Seal, or Tremco.

Physical Characteristics and Properties: Foamed-In-Place Wall Insulation shall equal or exceed the following:

- A. Free Rise Core Density: 2.0 lbs/cu.ft. per ASTM D-1622
- B. Compressive Strength: 27 psi (min) per ASTM D-1621
- C. R-Value: 6.8 (min) per inch, 13 per 2 inches, per ASTM C-518
- D. Moisture Vapor Transmission: 1.3 perm per inch, 0.65 perm at 2" thick, per ASTM E 283 and 2178
- E. Water Resistive Barrier: No Penetration per a 6.24 psf test condition, ASTM E-331
- F. Air Leakage Certification: 0 at 1.57 psf, per ASTM E-283 and 2178
- G. Surface Burning Characteristics: Flame Spread Index < 25 and Smoke Developed Index < 450 per ASTM E-84

Acceptable Products:

- A. InsulBloc Spray Foam System 11-017 by NCFI Polyurethanes, PO Box 1528, Mt. Airy, NC 27030
- B. Equivalent products by Polymaster.
- C. Equivalent products by CertainTeed.
- D. Or equivalent products per information submitted to and accepted by the Architect.

Quality Assurance:

- A. Compliance with AC 377 and ASTM C1029.
- B. Insulation shall be installed per the manufacturer's printed instruction submitted to the Architect prior to the start of work.

- C. Insulation shall be installed by a contract installer who has been trained and certified by the manufacturer. The contract installer shall have not less than three (3) years experience in the trade and be properly licensed to perform the scope of work.
- D. Follow and adhere to all manufacturer's and OSHA safety guidelines.
- E. Upon completion of the installation, the contract installer shall provide 4-color infrared thermal images of all exterior wall surfaces to the Architect to confirm that the spray applied cavity insulation completely covers all surfaces required to be insulated, with the required thickness. If the thermal images show voids, the contract installer shall apply foam to correct the deficiency at no added cost to the Owner.
- F. Provide a one year product performance warranty by the manufacturer.

Barrier System Required in Areas Not Protected with Drywall or Masonry:

- A. Areas of Spray Foam Insulation not protected with Drywall or Masonry shall be protected with an approved intumescent covering, equal to International Fireproofing Technologies, Inc., "DC-315", spray applied 21 mils wet / 14 mils dry minimum, meeting all requirements of the NC Building Code and IRC. Refer to Section 09860.

EXTERIOR BELOW GRADE WATERPROOFING

WATERPROOFING MEMBRANE (at Gymnasium wood floor perimeter): MEL-ROL, Rolled, Self-Adhering Waterproofing Membrane, manufactured by W. R. Meadows. General contractor to apply to all perimeter foundation walls at the Gymnasium wood floor. Reference Section 09550 Wood Flooring.

Where indicated on Drawings, provide hot mopped liquid asphalt on three inter-mopped layers of #30 lb. asphalt roofing felts, all bonding together and flood coated with hot liquid asphalt.

CEILING INSULATION:

Unfaced Blanket-type Glass Fiber Ceiling Insulation: Inorganic non-asbestos fibers formed into semi-rigid blankets, R-13, 24" x 48" batt size. Do not insulate over lighting fixtures. Provide over all ceilings, unless otherwise noted.

SOUND ATTENUATION BATT INSULATION:

Sound Attenuation Batt Insulation: Mineral wool blankets, 2 1/2" thick, manufactured by USG, USM, Owens-Corning or equal providing STC ratings scheduled. Install in strict accordance with manufacturer's printed instructions and at all interior metal stud / gypsum wallboard partitions. Provide all necessary anchoring accessories and devices for a complete no-sag installation.

PART 3: EXECUTION

INSPECTION AND PREPARATION:

Installer must examine substrates and conditions under which insulation work is to be performed, and must notify Contractor in writing of unsatisfactory conditions. Do not proceed with insulation work until unsatisfactory conditions have been corrected in manner acceptable to Installer.

Clean substrates of substances harmful to insulations or vapor barriers, including removal of projections which might puncture vapor barriers.

INSTALLATION:

General:

Comply with manufacturer's instructions for particular conditions of installation in each case. If printed instructions are not available or do not apply to project conditions, consult manufacturer's technical representative for specific recommendations before proceeding with work.

Extend insulation full thickness as shown over entire area to be insulated. Spray, cut and fit tightly around obstructions, and fill voids with insulation. Remove projections which interfere with placement.

END OF SECTION

RELATED DOCUMENTS:

Drawings and general provisions of Contract, including General and Supplementary Conditions and Division-1 Specification sections, apply to work of this section.

PART 1 – GENERAL

Work Included:

The work to be performed under this section shall include all materials, equipment, labor and services required to install the sprayed cellulose fiber in accordance with these specifications and as indicated on the drawings.

A representative surface of not less than 100 square feet shall be sprayed and approved by the Architect and/or Owner prior to proceeding.

Related Work:

Surfaces previously coated with cementitious spray-on fireproofing.

Clips, hangers, supports, sleeves and other attachments to spray bases are to be placed by other trades prior to the application of sprayed insulation.

Ducts, piping, conduit or other suspended equipment shall not be positioned until after the application of sprayed insulation.

Paint 09900: Coordinate and complete finish painting of all adjacent overhead roof structure prior to application of spray acoustical insulation.

Systems Description/Quality Assurance:

Contractor must use a total system, encompassing equipment, fiber and adhesive as supplied and tested by the manufacturer. No substitution may be made.

Fibers supplied under this specification shall have each bag coded with the date and lot number of manufacture, and retained samples shall be kept by the manufacturer for not less than one year.

Contractor must be licensed and trained by the manufacturer.

Submittals:

Submit product data and manufacturer's certificate that the product meets or exceeds specified requirements.

Manufacturer's written certification that product contains no asbestos, fiberglass or other man made mineral fibers.

Certification that spray-on acoustical insulation is compatible with cementitious spray-on fireproofing.

Product Delivery, Storage and Handling:

Materials shall be delivered in original, unopened containers bearing name of manufacturer, product identification and reference to U.L. testing.

Store materials off ground, under cover and away from damp surfaces and keep material dry at all times.

Protect liquid adhesive from freezing.

PART 2: PRODUCTS

Manufacturers: Product specification is based on the following manufacturer. Other manufacturer's who can provide an equivalent product/system will also be approved for use.

"K-13" by International Cellulose Corporation
12315 Robin Boulevard
Houston, Texas 77045
(713) 433-6701 or (800) 444-1252
Fax: (713) 433-2029

Materials:

Spray-On-Systems, sprayed cellulose fiber.

1. Color shall be: Black and White - See Drawings for locations.
2. Thickness: 2.0" minimum, with a minimum 1.05 NRC Rating.
3. Field-tested bond strength report per ASTM E-736.

Tested @ > 5 years
Not less than 400 psf
Not less than 600 times its weight @ 1"

4. The sprayed insulation must have been tested in sprayed form by U.L. and have each bag labeled with the reference to U.L. test results according to ASTM E-84/U.L. 723:

Tested at a minimum of 5" thickness, Class I
Flame Spread Not To Exceed 5
Smoke Development Not To Exceed 5

5. The sprayed insulation must meet appropriate Building Code Requirements.
6. The sprayed insulation must meet ASTM E-1042.
7. Non corrosive per UMB-80.
8. Bond Deflection per ASTM E-759. 6" Deflection in 10' Span – No Spalling or Delamination
9. Cohesive Strength at time of application per Method WS-2000: > 700 Grams
10. Urea-formaldehyde resins are prohibited.

PART 3 - EXECUTION

Inspection-Preparation-Installation:

- A. The installing contractor shall examine all surfaces and report all unsatisfactory conditions in writing to the General Contractor and Architect. The work shall not proceed until unsatisfactory conditions are corrected.

- B. Provide masking, drop cloths or other satisfactory coverings for all materials/surfaces which are not to receive insulation to prevent damage from over-spray.
- C. Surfaces to receive spray insulation shall be inspected prior to application to determine if priming/sealing is required to insure bonding and/or to prevent discoloration caused by migratory stains. Prime accordingly.
- D. Thickness will be determined as specified as per Part 2.
- E. The work shall be coordinated with other trades whose work may be affected or have an effect on the installation of the sprayed cellulose fiber.
- F. Coordinate with painted roof structure surfaces.
- G. Installation, clean up and curing shall be accomplished according to the manufacturer's recommendations and common construction standards.
- H. Provide natural or mechanical ventilation continuously to properly cure the insulation.

Protection:

Protect finished installation under provision of section 01500 and 01535.

All finished spray acoustical surfaces contaminated with paint overspray shall be re-applied and restored to color matching like new condition.

END OF SECTION

RELATED DOCUMENTS:

Drawings and general provisions of Contract, including General and Supplementary Conditions and Division-1 Specification sections, apply to work of this section.

PART 1: GENERAL

TYPE AND SEQUENCE OF CONSTRUCTION

New roof insulation over new steel roof deck. New roof system shall meet fire resistance Class A requirements and wind uplift resistance meeting ASTM E1592 and UL/FM I-90.

RELATED SECTIONS

07610 Metal Roofing

SUBMITTALS

Product Data:

1. Product data sheets.
2. Product samples.

DELIVERY, STORAGE, AND HANDLING

Deliver and store products according to general requirements for materials and equipment and Part 3 of this Section.

Provide unopened containers and packages with labels bearing producer(s) name and source of product and date of manufacture. Factory Mutual approval or Underwriters Laboratories Classification shall be on package.

Keep roof insulation protected while in storage; keep dry during application. Outdoors, store off ground on pallets protected with breathing type covers. Roof insulation which has been wet, and then dried, may be used only if approved by Architect.

ENVIRONMENTAL REQUIREMENTS

Install roof insulation only when surfaces are dry.

Do not install roof insulation if moisture content of substrate is above that acceptable to roof insulation and roof membrane producer.

PART 2: PRODUCTS

ROOF INSULATION

Product: Rigid polyisocyanurate board, with a coated glass-fiber facer conforming to or exceeding the requirements of ASTM C 1289, Type II, Class 1, Grade 3 (25 psi), in compliance with FM Standard 4450/4470, and UL Standard 1897 Uplift resistance.

Equivalent to: ENRGY 3 Polyisocyanurate Roof Insulation, by Johns Manville

ACFOAM-II Polyisocyanurate Roof Insulation, by Atlas

Thickness: 2 layers/courses; for a total R-25 assembly

<u>Property</u>	<u>Test Method</u>	<u>Value</u>
Tensile Strength:	ASTM C209	730 psf
Thermal Resistance (LTTR):	ASTM C518	R 5.7 per inch
Water Absorption:	ASTM C209	1.0% by volume, maximum
Water Vapor Permeance:	ASTM E96	1.5 perm maximum
Dimensional Stability:	ASTM 2126	2% linear change, maximum
Maximum Operating Temperature:	ASTM D 1623	-100 F to 250 F
Product Density:	ASTM D1622	Nominal 2 pcf
Compressive Strength:	ASTM D1621	Grade 3: 25 psi minimum
Flame Spread:	ASTM E84	20-30
Smoke Developed:	ASTM E84	55-250

Referenced Standards:

Section 2603, FOAM PLASTIC INSULATION, International Building Code

ASTM: ASTM C 1289, Type II, Class 1

Underwriters Laboratories: Class A for Roof System External Flame – UL Standard 790

Insulation shall meet criteria for UL 1256 for a fire classified system.

Underwriters Laboratories: UL Construction No. 263

FM Standards 4450 / 4470

Acceptable Alternate Insulation: Styrofoam Deckmate XPS extruded polystyrene, R 5.0 per inch @ 75 degrees F mean. Compressive Strength: 40 psi. Comply with ASTM C578-01, Type IV. General Contractor is responsible for monitoring the specified R-25 R-Value assembly and accounting for any change in insulation thickness, with roof metal adjustments.

PART 3: EXECUTION

ROOF INSULATION APPLICATION:

GENERAL

Lay roof insulation in staggered courses parallel to roof edges.

Stagger end joints of each course, both layers.

Miter and foam insulate roof insulation edges at ridges, valleys, and other similar non-planar conditions. Butt edges to provide moderate contact; do not smash edges. Provided in layers specified with each layer's joints taped.

PROTECTION

Protect roofing work from foot traffic and construction damage.

CLEAN UP

Remove excess materials, trash, debris, equipment, and parts from the Work.

Repair, or remove and replace, damage and stains caused by roofing work.

FIELD QUALITY CONTROL:

Protection: If work is stopped before completion of application of roof insulation and roofing, protect exposed insulation. Seal edges to prevent penetration of moisture. Do not lay more insulation in one working day than can be covered by roofing in same day.

Inspection: Architect shall be notified to inspect work after completion of vapor barrier and completion of roof insulation. If this examination discloses that work is not according to Specification, or that work has been damaged by traffic or other trades, Contractor shall agree to furnish additional materials necessary to make repairs and place work in acceptable condition.

END OF SECTION

RELATED DOCUMENTS:

The general provisions of the Contract, including General and Supplementary Conditions, and General Requirements, and Division 1 specifications and Technical Specification Divisions 2 through 16 that apply to the work specified in this Section.

PART 1 - GENERAL

A. SECTION INCLUDES

1. The extent of panel system work is indicated on the drawings and in these specifications.
2. Panel system requirements include the following components:
 - a. Aluminum faced composite panels complete with mounting system. Factory formed shapes, panel mounting system including reveal joint extrusions, anchorages, shims, furring, fasteners, gaskets and sealants, related flashing adapters, and masking (as required) for a complete watertight installation.

B. RELATED WORK SPECIFIED ELSEWHERE

1. Division 5 Sections
2. Division 6 Sections
3. Section 07200: Insulation
4. Section 07600: Metal flashing and counter flashing.
5. Section 07610: Metal Roofing
6. Section 07920: Caulking and sealants.

QUALITY ASSURANCE

- A. Composite Panel Manufacturer shall have a minimum of 5 years experience in the manufacturing of this product.
- B. Composite Panel Manufacturer shall be solely responsible for panel manufacture and application of Kynar finish.
- C. Fabricator/Installer shall be one in the same. No sub-letting or brokering of trade.
- D. Fabricator/Installer shall have a minimum 5 years experience of metal panel work similar in scope and size to this project.
- E. Field measurements should be taken prior to the completion of shop fabrication. Coordinate fabrication schedule with construction progress as directed by the Contractor to avoid delay of work. Field fabrication may be allowed to ensure proper fit. However, field fabrication shall be kept to an absolute minimum with the majority of the fabrication being done under controlled shop conditions.
- F. Shop drawings shall show the preferred joint details providing a watertight and structurally sound wall panel system that allows no uncontrolled water penetration on the inside face of the panel system as determined by ASTM E 331.

- G. Maximum deviation from vertical and horizontal alignment of erected panels: 1/4" in 20' non-accumulative.
- H. Panel fabricator/installer shall assume undivided responsibility for all components of the exterior panel system including, but not limited to attachment to sub-construction, panel to panel joinery, panel to dissimilar material joinery, and joint seal associated with the panel system.
- I. Composite panel manufacturer shall have established a Certification Program acceptable to the local Code Authorities.

REFERENCES

- A. Aluminum Association
 - 1. AA-C22-A41: Anodized - Clear Coatings.
 - 2. AA-C22-A42: Anodized - Integral Color Coatings.
- B. American Society for Testing and Materials
 - 1. E 330-84: Structural Performance of Exterior Windows, Curtain Walls, and Doors Under the Influence of Wind Loads.
 - 2. E 283-84: Rate of Leakage through Exterior Windows, Curtain Walls, and Doors.
 - 3. D 1781-76: Climbing Drum Peel Test for Adhesives.
 - 4. E 84-79: Surface Burning Characteristics of Building Materials.
 - 5. E 162-83: Surface Flammability of Materials Using a Radiant Heat Energy Source.
 - 6. D 3363-74: Method for Film Hardness by Pencil Test.
 - 7. D 2794-90: Resistance of Organic Coatings to the Effects of Rapid Deformation (Impact).
 - 8. D 3359-90: Methods for Measuring Adhesion by Tape Test.
 - 9. D 2247-87: Practice for Testing Water Resistance of Coatings in 100% Relative Humidity.
 - 10. B 117: Method of Salt Spray (Fog) Testing.
 - 11. D 822: Practice for Operating Light and Water Exposure Apparatus (Carbon-Arc Type) for testing Paint, Varnish, Lacquer, and Related Products.
 - 12. D 1308-87: Effect of Household Chemicals on Clear and Pigmented Organic Finishes
 - 13. D 1735: Method for Water Fog Testing of Organic Coatings.
- C. International Conference of Building Officials
 - 1. UBC 17-5: Room Fire Test Standard for Interior of Foam Plastic Systems.

SUBMITTALS

- A. Submittals shall be in conformance with Section 01050.
- B. Samples
 - 1. Panel System Assembly: Two samples of each type of assembly. 12" x 12" minimum.

2. Two samples of each standard and premium colors, 3" x 4" minimum.
3. Physical color samples in the specified colors.
- C. Shop Drawings: Submit shop drawings showing project layout and elevations; fastening and anchoring methods; detail and location of joints, sealants, and gaskets, including joints necessary to accommodate thermal movement; trim; flashing; and accessories.
- D. Affidavit certifying material meets requirements specified.
- E. Two copies of manufacturer's literature for panel material.
- F. Physical full sized mockup on site for review and approval.

DELIVERY, STORAGE AND HANDLING

- A. Protect finish and edges in accordance with panel manufacturer's recommendations.
- B. Store material in accordance with panel manufacturer's recommendations.

PART 2: PRODUCTS

PANELS

- A. Composite Panels
 1. ALUCOBOND PLUS aluminum composite material manufactured by 3A Composites, Inc. USA.
 2. Items of the same function and performance which have received prior approval from the Architect shall be allowed for this project. Approval shall be based on documentation submitted showing compliance with this material specification and Drawings.
- B. Thickness: 4mm (0.157")
- C. Product Performance
 1. Bond Integrity

When tested for bond integrity, in accordance with ASTM D1781-76 (simulating resistance to panel delamination), there shall be no adhesive failure of the bond a) between the core and the skin nor b) cohesive failure of the core itself below the following values.

Bond Strength: 214 psi (Vertical Pull)

Peel Strength: 22.5 in lb/in as manufactured

22.5 in lb/in after 8 hours in water at 200°F

22.5 in lb/in after 21 days soaking in water at 70°F
 2. Fire Performance

ASTM E84-79 - Flame Spread 0, Smoke Developed 0
ASTM E162 - No surface flaming
UBC 17-5 - No flame spread along interior face or penetration through the wall assembly.

D. Finishes

1. Coil coated KYNAR® 500 or HYLAR® 5000 based polyvinylidene fluoride (2-coat PVDF fluoropolymer) resin in conformance with the following general requirements of AAMA 2605.
 - a. Color - 2 coat colors: Only Alucabond Plus, PVDF-2 (2 coat) 14 Mica color choices, as selected by the Architect from the manufacturer's Alucabond Plus color palettes.
 - b. Coating: Dry Film Thickness, ASTM D1400
 - 1) 0.25 mil primer, +/- 0.05 mils
 - 2) 1.0 mil minimum topcoat
 - c. Hardness: ASTM D-3363; F minimum using Eagle Turquoise Pencil.
 - d. Impact:
 - 1) Test method: ASTM D-2794; Gardner Variable Impact Tester with 5/8" mandrel.
 - 2) Coating shall withstand reverse impact of 1.5"/pounds per mil substrate thickness.
 - 3) Coating shall adhere tightly to metal when subjected to #600 Scotch Tape pick-off test. Slight minute cracking permissible. No removal of film to substrate.
 - e. Adhesion:
 - 1) Test Method: ASTM D-3359.
 - 2) Coating shall not pick off when subjected to an 11" x 11" x 1/16" grid and taped with #600 Scotch Tape.
 - f. Humidity Resistance
 - 1) Test Method: ASTM D-2247.
 - 2) No formation of blisters when subjected to condensing water fog at 100% relative humidity and 100°F for 3000 hours.
 - g. Salt Spray Resistance:
 - 1) Test Method: ASTM B-117; Expose coating system to 3000 hours, using 5% NaCl solution.
 - 2) Corrosion creepage from scribe line: 1/16" max.
 - 3) Minimum blister rating of 8 within the test specimen field.
 - h. Weather Exposure
 - 1) Outdoor:
 - a. Five year exposure at 45° angle facing south Florida exposure.
 - b. Maximum color change of 5 Delta E units as calculated in accordance with ASTM D-2244.
 - c. Maximum chalk rating of 8 in accordance with ASTM D-659.
 - d. No checking, crazing, adhesion loss.
 - 2) Accelerated:
 - a. ASTM D-822, 5000 hours in Atlas Type Weatherometer; using cycle of 102 minutes light and 18 minutes diminished light and demineralized water.
 - b. No checking, crazing, adhesion loss or objectionable color change or chalking.
 - i. Chemical Resistance:
 - 1) ASTM D-1308 utilizing 10% Muriatic Acid for an exposure time of 15 minutes.
 - 2) ASTM D-1308 utilizing 20% Sulfuric Acid for an exposure time of 18 hours.
 - 3) No loss of adhesion or gloss and no color change.

PANEL FABRICATION

- A. Composition: Two sheets of aluminum sandwiching a solid core of extruded thermoplastic material formed in a continuous process with no glues or adhesives between dissimilar materials. The core material shall be free of voids and/or air spaces and not contain foamed insulation material.

Products laminated sheet by sheet in a batch process using glues or adhesives between materials shall not be acceptable.

Provide factory formed shapes, with radiuses and bends as indicated on Drawings.

B. Aluminum Face Sheets:

1. Thickness: 0.50mm (0.020")
 - a. Alloy: AA3003 Painted material

C. Panel Weight:

1. 4mm (0.157"): 1.56 lbs./ft²

D. Tolerances

1. Panel Bow: Maximum 0.8% of any 1828mm (72") panel dimension.
2. Panel Dimensions: Field fabrication shall be allowed where necessary, but shall be kept to an absolute minimum. All fabrication shall be done under controlled shop conditions when possible.
3. Panel lines, breaks, and angles shall be sharp, true, and surfaces free from warp and buckle.
4. Maximum deviation from panel flatness shall be 1/8" in 5'0" on panel in any direction for assembled units. (Non-accumulative - No Oil Canning)

E. System Type: Rout and Return Wet:

System must provide a wet seal (caulked) reveal joint as detailed on drawings. The sealant type shall be as specified in Section 07900 and with foamed type backer rod as indicated on architectural drawings.

F. System Characteristics

Plans, elevations, details, characteristics, and other requirements indicated are based upon standards by one manufacturer. It is intended that other manufacturers, receiving prior approval, may be acceptable, provided their details and characteristics comply with size and profile requirements, and material/performance standards as follows:

1. Composite panels shall be capable of withstanding building movements and weather exposures based on the following test standards required by the Architect and/or the local building code.

a. Wind Load

If system tests are not available, mock-ups shall be constructed and tests performed under the direction of an independent third party laboratory, which show compliance to the following minimum standards:

Panels shall be designed to withstand the Design Wind Load based upon the local building code, but in no case less than 20 pounds per square foot (psf) and 30 psf on parapet and corner panels. Wind load testing shall be conducted in accordance with ASTM E330 to obtain the following results.

Normal to the plane of the wall between supports, deflection of the secured perimeter-framing members shall not exceed $L/175$ or $3/4"$, whichever is less.

Normal to the plane of the wall, the maximum panel deflection shall not exceed $L/60$ of the full span.

Maximum anchor deflection shall not exceed $1/16"$.

At 1-1/2 times design pressure, permanent deflections of framing members shall not exceed $L/100$ of span length and components shall not experience failure or gross

permanent distortion. At connection points of framing members to anchors, permanent set shall not exceed 1/16".

b. Air/Water System Test

If system tests are not available, mock-ups shall be constructed and tests performed under the direction of an independent third party laboratory, which show compliance to the following minimum standards:

Air Infiltration - When tested in accordance with ASTM E283, air infiltration at 1.57 psf must not exceed 0.06 cfm/ft² of wall area.

Water Infiltration - Water infiltration is defined as uncontrolled water leakage through the exterior face of the assembly. Systems not using a construction sealant at the panel joints (i.e. Rout and Return Dry and Rear Ventilated Systems) shall be designed to drain any water leakage occurring at the joints. No water infiltration shall occur in any system under a differential static pressure of 6.24 psf after 15 minutes of exposure in accordance with ASTM E331.

ACCESSORIES

- A. Extrusions, formed members, sheet, and plate shall conform to ASTM B209 and the recommendations of the manufacturer. Reveals shall match color of adjacent panel material.
- B. Panel stiffeners, if required, shall be structurally fastened or restrained at the ends and shall be secured to the rear face of the composite panel with silicone of sufficient size and strength to maintain panel flatness. Stiffener material and/or finish shall be compatible with the silicone.
- C. Sealants and gaskets within the panel system shall be as per manufacturer's standards to meet performance requirements.
- D. Fabricate flashing materials from 0.030" minimum thickness aluminum sheet painted to match the adjacent curtain wall / panel system where exposed. Provide a lap strap under the flashing at abutted conditions and seal lapped surfaces with a full bed of non-hardening sealant.
- E. Fasteners (concealed and non-corrosive): Fasteners as recommended by panel manufacturer. Do not expose fasteners except where unavoidable and then match finish of adjoining metal.

PART 3: EXECUTION

INSPECTION

- A. Surfaces to receive panels shall be even, smooth, sound, clean, dry and free from defects detrimental to work. Notify contractor in writing of conditions detrimental to proper and timely completion of the work. Do not proceed with erection until unsatisfactory conditions have been corrected.
- B. Surfaces to receive panels shall be structurally sound as determined by a registered Architect/Engineer.

INSTALLATION

- A. Erect panels plumb, level, and true.
- B. Attachment system shall allow for the free and noiseless vertical and horizontal thermal movement due to expansion and contraction for a material temperature range of -20°F to +180°F. Buckling of panels, opening of joints, undue stress on fasteners, failure of sealants or any other detrimental

effects due to thermal movement will not be permitted. Fabrication, assembly, and erection procedure shall account for the ambient temperature at the time of the respective operation.

- C. Panels shall be erected in accordance with an approved set of shop drawings.
- D. Anchor panels securely per engineering recommendations and in accordance with approved shop drawings to allow for necessary thermal movement and structural support.
- E. Conform to panel fabricator's instructions for installation of concealed fasteners.
- F. Do not install component parts which are observed to be defective, including; warped, bowed, dented, abraided, and broken members.
- G. Do not cut, trim, weld, or braze component parts during erection in a manner which would damage the finish, decrease strength, or result in visual imperfection or a failure in performance. Return component parts which require alteration to shop for refabrication, if possible, or for replacement with new parts.
- H. Separate dissimilar metals and use gasketed fasteners where needed to eliminate the possibility of corrosive or electrolytic action between metals.

ADJUSTING AND CLEANING

- A. Remove and replace panels damaged beyond repair as a direct result of the panel installation. After installation, panel repair and replacement shall become the responsibility of the General Contractor.
- B. Repair panels with minor damage.
- C. Remove masking (if used) as soon as possible after installation. Masking intentionally left in place after panel installation on an elevation, shall become the responsibility of the General Contractor.
- D. Any additional protection, after installation, shall be the responsibility of the General contractor.
- E. Make sure weep holes and drainage channels are unobstructed and free of dirt and sealants.
- F. Final cleaning shall not be part of the work of this section.

END OF SECTION

RELATED DOCUMENTS:

The general provisions of the Contract, including General and Supplementary Conditions, and General Requirements, and Division 1 specifications that apply to the work specified in this Section.

PART 1 - GENERAL

RELATED WORK SPECIFIED ELSEWHERE:

07415 Aluminum Composite Panels
07610 Metal Roofing

DESCRIPTION OF WORK:

Contract work of this Section shall include, but not be limited to providing following:

All sheet metal work required for complete assemblies of items specified at all areas indicated on Drawings, including but not necessarily required:

- Gutters
- Downspouts
- Copings
- All sheet metal work required for moisture control
- Metal valley flashing
- Metal base flashings and counter flashings

INDUSTRY STANDARDS:

For listing of names of industry standard agencies mentioned by abbreviation in this Section refer to Section 01068.

Standards: Workmanship and methods employed for forming, anchoring, cleating, and expansion and contraction of sheet metal work shall conform to application details and description as indicated in current edition of Architectural Sheet Metal Manual, published by Sheet Metal and Air Conditioning Contractors National Association, Inc. and hereinafter referred to as "SMACNA Manual", unless otherwise noted on Contract Drawings or specified herein.

QUALITY ASSURANCE:

Manufacturers:

Standard: For purposes of designating type and quality for the work under this Section, Drawings, and Specifications are based on products manufactured or furnished by Manufacturers listed under PRODUCTS.

SUBMITTALS:

Shop Drawings: Submit for approval in accordance with GENERAL CONDITIONS.

Details and layout shall show weights, gauges or thicknesses of sheet metal, joints, expansion joint spacing, and procedures to be followed during installation. Indicate bolt size and spacing, nailers or blocking required to be furnished by others for securing work of this Section.

Catalog Cuts: For Standard manufactured items, catalog cuts may be submitted as specified in GENERAL CONDITIONS.

Guarantee: Installation of all items of this Section shall be guaranteed to be leak-free for period of five years from date of acceptance of project. Any repairs or replacements required to maintain waterproof installation shall be done at no cost to Owner.

PRODUCT HANDLING:

Handling and Storage: Damaged items that cannot be restored to like-new condition shall be removed and replaced at no additional cost to Owner.

PART 2 - PRODUCTS

MATERIALS:

Flatwork, Flashings, Copings, Gutters and Gravel Stops: Pre-finished 24 gauge galvalume steel sheet, 0.5 ounces/square foot, minimum yield of 50,000 PSI.

Gutter: 24 gauge pre-finished galvalume steel gutter. Provide pre-finished gutter spacers and brackets as shown on Drawings.

Downspouts: Downspouts, 20 gauge pre-finished galvalume steel, Kynar 500 finish. Wall mounting 2-piece brackets shall be matching material.

Finish/Colors: Premium 70% PVDF fluorocarbon coating produced with Kynar 500 or Hylar 5000 resin.

ACCESSORIES:

General: Provide all accessories or other items essential to completeness of sheet metal installation, though not specifically shown or specified. All such items shall be of same material or compatible to base material to which applied and gauges shall conform to SMACNA Manual recommendations.

Fasteners: All screws, bolts, rivets and other fastenings for sheet metal, unless otherwise noted, shall be like material and of size and type suitable for intended use, stainless where indicated.

Sealant: Elastomeric polyurethane sealant equal to Sonneborn Sonolastic NP-1. Clean all sheet metal surfaces prior to application with xylene and prime with Primer equal to Sonneborn 733 primer. Follow manufacturer's written product installation guidelines, recommendations and instructions. Color to be selected by Architect.

PART 3 - EXECUTION

CONDITION OF SURFACES:

Proper Surfaces: Surfaces to which sheet metal and flashing are applied shall be even, smooth, sound, thoroughly clean and dry and free from projections or other defects that would affect application. Defects shall be corrected by trades involved before installation of sheet metal work.

INSTALLATION:

Workmanship: Fabricate and install sheet metal with lines, arises, and angles sharp and true, and plane surfaces free from waves warps, or buckles, match existing work unless shown otherwise. Exposed edges

of sheet metal shall be folded back to form 1/2 inch wide hem on side concealed from view. Finished work shall be free from water leakage under all weather conditions.

Fastenings: Unless otherwise indicated or specified, all fastenings shall be concealed. Installation of and joints of all sheet metal work, including fascia claddings, shall be in accordance with recommendations of SMACNA.

END OF SECTION

RELATED DOCUMENTS:

Drawings and general provisions of Contract, including General and Supplementary Conditions and Division-1 Specification sections, apply to work of this section.

PART 1: GENERAL

1.01 DESCRIPTION

A. General

1. Furnish all labor, material, tools, equipment, and services for a complete roofing and wall panel system, and soffit panel system to include all flashings, curbs, gutters and downspouts as indicated, in accordance with provisions of Contract Documents.
2. Completely coordinate with work of all other trades.
3. Although such work is not specifically indicated, furnish and install all supplementary or miscellaneous items, appurtenances and devices incidental to or necessary for a sound, secure and complete installation.
4. See Division 1 for General Requirements.

B. Related work specified elsewhere:

1. Flashing and Sheet Metal: Section 07600.
2. Aluminum Composite Panels: Section 07415
3. Drawings Building Code Summary

1.02 QUALITY ASSURANCE

A. Applicable standards:

1. SMACNA: "Architectural Sheet Metal Manual" Sheet Metal and Air Conditioning Contractors National Association, Inc.
2. AISC: "Steel Construction Manual" American Institute of Steel Construction.
3. AISI: "Cold Form Steel Design Manual," American Iron and Steel Institute.
4. ASTM A792-AZ50: Specifications for steel sheet, aluminum-zinc alloy coated (galvanized) by the hot dip process, general requirements (galvalume).
5. Underwriters Laboratories Inc. wind uplift classification UL 90
6. 2000 International Building Code, Table 1604.5, Classification Of Buildings And Other Structures For Importance Factors, Category II Seismic, Snow and Wind Factors.
7. 2000 International Building Code, Table 1604.5, Classification Of Buildings And Other Structures For Importance Factors, Category III Seismic, Snow and Wind Factors.
8. LEEDS NC, U. S. Green Building Council

9. Energy Star Roof Rating
 10. Cool Metal Roof Coalition
 11. Cool Roof Rating Council
- B. Manufacturer's qualifications:
1. Manufacturer has a minimum of three years experience in manufacturing panels of this nature.
- C. Installer's qualifications:
1. Installation of panels and accessories by installers with a minimum of two years experience in panel projects of this nature.

1.03 SUBMITTALS

- A. Shop drawings:
1. Submit complete shop drawings and erection details to Architect for review. Do not proceed with manufacture prior to review of shop drawings. Do not use drawings prepared by Architect for shop or erection drawings.
 2. Shop drawings show methods of erection, elevations, and plans of roof and wall panels, sections and details, anticipated loads, flashings, roof curbs, vents, sealants, interfaces with all materials not supplied and proposed identification of component parts and their finishes.
 3. Manufacturer's Information: Describe available LEED points.
 4. Certification: Manufacturer to certify that roof system submitted is in compliance with Building Category Importance Factors requirements
- B. Mockups and Samples:
1. Roofing contractor to build a full-sized roof corner mockup on-site for review and approval by the Architect. Roof corner mockup to include roof metal rake intersection with eave metal gutter and fascia.
 2. Submit samples and color chips for all proposed finishes.
 - a. Submit one 8 in. long sample of roof panel, including clips.
 - b. Submit one 8 in. long sample of wall panel, including clips.
 - c. Submit 3 in. x 5 in. color chip samples in all standard colors.
- C. LEEDS NC: Submit certification from Manufacturer of roofing materials and accessories that products are sustainable products, listing all applicable LEED U.S. Green Building code council's credits made available by certification.
- D. Warranty
1. Provide contractor's written NDL (No Dollar Limit) weathertightness warranty twenty (20) years, against leaks in roof panels arising out of or caused by ordinary wear and tear under normal weather and atmospheric conditions. Warranty coverage shall include all

curbs, flashing and miscellaneous trim and accessories. Warranty shall be non-pro-rated, signed by the metal roofing system contractor and shall provide for both labor and materials.

2. Provide manufacturer's NDL (No Dollar Limit) written warranty for twenty (20) years against perforation of metal roof panels due to corrosion under normal weather and atmospheric conditions. Warranty shall be signed by metal roofing system manufacturer and shall provide for complete replacement of panels and associated trim.
3. Provide manufacturer's NDL (No Dollar Limit) written paint film warranty for twenty (20) years on finish film integrity and color retention. The finish will not crack, check, peel, flake, or blister, or chalk in excess of ASTM 4214, number 8 rating, or fade in excess of 5 units per ASTM D 2244, under normal atmospheric conditions. Warranty shall be signed by metal roof system manufacturer.
4. Inspection and Report Services: Contractor shall retain independent third party agent who shall perform an inspection of the entire roof system and shall submit a written report to the Owner detailing all conditions requiring maintenance and repair by parties under the above warranties. Third party agent shall be a registered roof consultant (RRC) with minimum of 5 years as a registered roof consultant and 5 years of active project experience. Provide written certification of qualifications.

1.04 PRODUCT DELIVERY, STORAGE AND HANDLING

- A. Obtain roofing products from local regional source, within 500 miles of project site.
- B. Delivery: Deliver panels to jobsite properly packaged to provide protection against transportation damage.
- C. Handling: Exercise extreme care in unloading, storing and erecting panels to prevent bending, warping, twisting, and surface damage.
- D. Storage: Store all material and accessories above ground on well skidded platforms. Store under water- proof covering. Provide proper ventilation to panels to prevent condensation build-up between each panel.

PART 2: PRODUCTS

2.01 MATERIALS

- A. Roof panel profile: 2 in. high x 3/4 in. wide rib x 16 in. wide striated panel.
- B. Panel style: Large batten, vertical leg, concealed fastener, standing seam, utilizing male and female rib configurations, with factory applied hot melt mastic in female rib, continuously locked together by an electrically powered mechanical seaming device during installation.
- C. Gauge: 24 gauge (UL-90 rated - Underwriters Laboratories).
- D. Substrate: Galvalume steel sheet, 0.5 ounces/square foot, minimum yield of 50,000 PSI.
- E. Recycled Content: Metal roof materials shall be 35% recycled content.

- F. Clip: Floating clip, low profile, 22 gauge, with factory applied mastic (# UL-90 rated-Underwriters Laboratories).
- G. Texture: Smooth.
- H. Finish: Premium fluorocarbon coating produced with Kynar 500 or Hylar 5000 resin (20 year warranty).
- I. Reflectivity and Emissivity: Metal roof Panels shall be high reflectance and high remittance in accordance with Energy Star. Initial Reflectance (Galvalume Only) shall be at least 0.68 when tested with ASTM E-903. The three year aged reflectance shall be at least 0.57, when tested in accordance with ASTM E-1918 (Measured AS Solar Reflectivity, Not Visible Reflectance).
- J. Color: Selected from manufacturer's standard Energy Star Rated roof colors, with Solar Reflectance Index (SRI) value equal to or greater than SRI 29.
- K. Acceptable manufacturer: MBCI; Product: BattenLok Series
- L. Acceptable optional manufacturers:
 - 1. Equivalent products by:
 - i. CMP Construction Metal Products
 - ii. MRS Metal Roofing Systems
 - iii. American Building Company
 - iv. Butler Manufacturing Company
 - v. McElroy Metal, Maxima 216
- M. Provide downspouts in profiles, shapes and materials as indicated on Drawings, 24 gauge and 20 gauge galvalume galvanized steel with Kynar 500 or Hylar 5000 resin finish. Provide straps, brackets and anchors in matching material as indicated on Drawings.
- N. U-Channel Gutter Bracket Strap: Provide 16-gauge prefinished galvanized U-bar channel gutter strap, factory powder coat painted to match roof.
- O. Pipe flashing shall be Dektite, or equivalent by Master Flash, Westform Metals or IPS Roofing Products.
- P. Provide roof and gutter expansion joints as indicated on Drawings, in matching Kynar 500 or Hylar 5000 resin finish.
- Q. All roof curbs are by metal roof contractor. Refer to mechanical drawings and coordinate curbs required with HVAC Contractor.
- R. Provide special rolled / radiused panels and trim where shown on drawings.
- S. Provide special shapes where shown on drawings.
- T. Ribbed wall panels where indicated on Drawings shall be fabricated from 24 gauge Galvalume galvanized steel, 70% fluoropolymer Kynar 500 factory applied paint system with a 25-year finish warranty, formed to provide a weathertight closure assembly. Panel shall be a 12" wide x 1 ½" deep, with 2 beads at 4" on center, concealed fastener type, smooth textured, flat profiled with reverse rib fastener legs. Provide all accessories, trims, channels and flashings for a complete assembly. Provide panels equivalent to FW-120-2 Panel by MBCI.

- U. Where indicated, provide soffits of Aluminum Composite Panels and trim; complete with mounting system and in compliance with and coordinated with Section 07415.
- V. Where indicated, provide soffits of Metal Soffit Panels and trim; 22-gauge galvalume steel, flat profile and smooth textured, with a factory KYNAR 500 finish, selected from standard colors. Provide 12 inch wide smooth solid non-vented panels, unless otherwise noted. Soffit system shall be equivalent to Metal Roofing Systems (MRS) Flush Seam panel, or equivalent products by MBCI or CMP. Provide all necessary accessories and trims for complete assemblies.
- W. Self-adhering polymer modified bituminous membrane, 40 mil minimum thickness, Vycor Ice and Water Shield by W.R. Grace or equivalent products by GAF Materials Corp. or Calisle Coatings and Waterproofing.

2.02 FABRICATION

- A. Material shall be in-line tension leveled prior to roll forming finished panel profile.
- B. Factory roll form panels in continuous lengths, full length of detailed runs. Field formed panels will not be accepted.
- C. Standard panel length shall be no more than 45 feet.
- D. Panel laps shall be 5" minimum.
- E. Fabricate trim, flashing and accessories to detailed profiles.
- F. Fabricate trim and flashing from same material as panel.

PART 3: EXECUTION

3.01 SURFACE CONDITIONS

- A. Examination
 - 1. Inspect installed work of other trades and verify that such work is complete to a point where this work may continue.
 - 2. Verify that installation may be made in accordance with approved shop drawings and manufacturer's instructions.
- B. Discrepancies:
 - 1. In event of discrepancy, notify Architect.
 - 2. Do not proceed with installation until discrepancies have been resolved.

3.02 INSTALLATION

- A. Install panels so that they are weathertight, without waves, warps, buckles, fastening stresses or distortion, allowing for expansion and contraction.
- B. Install panels in accordance with manufacturer's instructions and shop drawings.
- C. Provide concealed anchors at all panel attachment locations.

- D. Install panels plumb, level, and straight with seams and ribs/battens parallel, conforming to design as indicated.
- E. Do not place scratched panels or material in the work.
- F. Metal roofing contractor is responsible for cutting and sealing all roof penetrations and installations of all curbs. Refer to plumbing and mechanical drawings. Coordinate roof penetrations and curbs required with Plumbing and HVAC Contractors.
- G. Install self-adhering polymer modified bituminous membrane ice and water shield, to cover entire roof surface.

3.03 CLEANING, PROTECTION

- A. Dispose of excess materials and remove debris from site.
- B. Clean work in accordance with manufacturer's recommendations.
- C. Protect work against damage until final acceptance. Replace or repair to the satisfaction of the Architect, any work that becomes damaged prior to final acceptance.
- D. Scratched panels or scratched flat surfaces will not be accepted. Scratched materials shall be replaced with new matching material at contractor's expense. Repainting to conceal surface scratches will not be accepted.

END OF SECTION

RELATED DOCUMENTS:

Drawings and general provisions of Contract, including General and Supplementary Conditions and Division-1 Specification sections, apply to work of this section.

PART 1: GENERAL

DESCRIPTION OF WORK :

Work of this Section shall require furnishing all labor and materials to provide sealants, non-rated caulking, fire-rated fire caulking, and related primers, including expansion joint fillers, interior and exterior, as shown on Drawings and as specified in this Section.

Caulking and primers required for installation of all work included in Sections for Window Wall, Storefront Systems shall be part of work under that Section and shall be done in accordance with the applicable portions of this Section.

Acoustical caulking for installation of gypsum board is specified in Section 09250.

Required applications of sealants and caulking include, but are not necessarily limited to, following general locations:

- Flashing reglets and retainers.
- Coping Members, Bed and Joints.
- Interior and exterior wall joints around doors and windows perimeters.
- Exterior wall control joints
- Horizontal and vertical interior CMU wall and structural steel joints
- Joints at penetrations of walls, decks and floors by piping and other services and equipment.
- Fire-rated penetrations of walls, decks and floors by piping and other services and equipment.
- Concrete walk and pavement expansion joints
- Exposed interior concrete floor slab control joints

Required applications of joint fillers and gaskets include, but are not necessarily limited to, the following general types of work and locations:

- Expansion joint fillers in structural concrete.
- Exterior wall expansion joint fillers.
- Fire-rated pipe and conduit through penetrations.

INDUSTRY STANDARDS:

For listing of names of industry standard agencies mentioned by abbreviation in this Section refer to Section 01068.

ASTM E 814 (UL 1479) Standard Tests of Penetration Firestop Systems

ASTM E 1966 (UL 2079) Standard Test Method for Fire Resistive Joint Systems

UL - Underwriters Laboratory

ASTM C 920

Comply with 21 CFR 177.2600 for sealants in contact with food.

LEED SC, U. S. Green Building Council

SCAQMD - South Coast Air Quality Management District

QUALITY ASSURANCE:

Manufacturers:

Standard: For purposes of designating type and quality for the work under this Section, Drawings and Specifications are based on products of Sonneborn BASF Corporation and 3M Corporation.

Source: Products for use on this Project shall be of one Manufacturer, unless noted specifically otherwise.

All sealants shall comply with requirements of the South Coast Air Quality Management District (SCAQMD) Rule #1168.

SUBMITTALS:

Manufacturer's Data: For information only, submit 2 copies of Manufacturer's specifications, installation instructions and recommendations for each type of material required. Include Manufacturer's published data, certifications or laboratory test reports indicating that each material complies with requirements. Show by transmittal that copy of instructions and recommendations has been distributed to installer.

Submit applicable UL Tested Assemblies for each type of fire-rated through penetration and fire-stopping required.

Certifications: Submit written certifications that all primers, backings, and caulking materials are chemically compatible with each other and with the overcoating or topcoating materials.

Submit environmental certifications from Manufacturers of all joint sealant materials products, listing all applicable LEED credits made available by certifications.

Samples:

Caulking and Sealants: Submit samples of interior and exterior caulking compounds and related sealants required for installation. Install 12" samples in the work on site in locations requested by the Architect, for review.

Joint Fillers and Gaskets: Submit 3, 12" long samples of each joint filler or gasket which will be reviewed by Architect for color and texture only. Compliance with all other requirements is exclusive responsibility of Contractor.

Guarantee: Furnish Owner, in care of Architect, guarantee in accordance with requirements of General Conditions for period of three (3) years from date of acceptance of project against defective workmanship and materials, warranting airtightness and water tightness of exterior sealant and installation. Repairs shall be made promptly or material replaced after proper notice at no additional cost to Owner.

PRODUCT HANDLING:

Store and handle materials in strict compliance with Manufacturer's instructions.

Store in original containers until ready for use. Damaged material will be rejected and shall be removed from site.

PART 2: PRODUCTS

JOINT BACKING MATERIAL:

Non-Traffic Joints: Except where otherwise specified, packing shall be closed-cell expanded polyethylene cord or square rod conforming to ASTM D 1752, or closed-cell vinyl type conforming to ASTM D 1667, Grade VE-41.

Floor Joints: Packing shall be closed cell neoprene cord or square rod conforming to ASTM C 509-66T, with minimum shore "A" hardness of 45.

Fire-Rated Through Penetrations: non-combustible rock wool type mineral wool.

NON-RATED CAULKING COMPOUNDS /SEALANTS

Interior Joints: Caulking, other than where sealant is called for, shall be a solvent free, low modulus, one-part silyl-terminated polyether, non-sag sealant. Tack free time shall be minimum 90 minutes. Material shall be butyl-free skinning type, paintable within one hour.

Latex sealants are restricted to use only in non-moving joints in drywall construction.

Sonolastic 150 VLM manufactured by Sonneborn, or approved equal, with 7.24% of post-consumer material recycled content, VOC (volatile organic content) of 2 g/L.

MasterSeal CR-100 two-component self-leveling 100% polyurea control joint filler, for interior exposed and bare concrete floor slab control joints; for Boiler and Mechanical rooms, utility and custodial spaces. Not for use under VCT or carpeting adhered type floor finishes.

Exterior Joints: Caulking for exterior joints other than where other sealant is called for, shall be polyurethane:

Sonneborn NP-1 for walls, with 5% of post-consumer material recycled content, VOC (volatile organic content) of 43 g/L.

Sonneborn NP-2 for walls, with 5% of post-consumer material recycled content, VOC (volatile organic content) when mixed of 53-80 g/L.

Sonolastic SL-1 or SL-2 for concrete expansion joints in non-vehicular traffic areas, with 5% of post-consumer material recycled content, VOC (volatile organic content) maximum of 104 g/L.

Sonomeric 1 for concrete expansion joints in vehicular traffic areas, with 5% of post-consumer material recycled content, VOC (volatile organic content) maximum of 128 g/L.

Approved equivalent products by Tremco or Pecora are acceptable.

PRIMER:

Type: Primer, where required by Sealant Manufacturer, shall be solution or compound designed to insure adhesion of sealant and shall be compatible with sealant.

Source: Material shall be provided by Sealant or Caulking Manufacturer and shall be selected for compatibility with sealant, with substrate and shall be non-staining.

PRODUCT COMPATIBILITY: All primer, backing, and caulking materials shall be chemically compatible with each other for use as an assembly, and with all surfaces in contact with these materials.

FIRE BARRIER SEALANTS

All fire caulk sealants used for fire barriers shall have been tested and passed the criteria of ASTM E 814 (UL 1479) Standard Tests of Penetration Firestop Systems, ASTM E 1966 (UL 2079) Standard Test Method for Fire Resistive Joint Systems and CAN/ULC-S115 Standard Method of Fire Tests of Firestop Systems. All fire caulk sealants shall meet the requirements of the IBC, IRC, IPC, IMC, NFPA 5000, NEC (NFPA 70), NFPA 101 and NBCC. All fire caulks shall be listed in a tested and published through penetration UL assembly.

3M Fire Barrier Sealant FD 150+: one-component, gun grade, latex based elastomeric sealant. Paintable and repairable; firestops construction joints, and through penetrations. Not acceptable for use with CPVC pipe. VOC (volatile organic content) of <250 g/L.

3M Fire Barrier Silicone Sealant 2000+: one-component, gun grade, natural cure silicone elastomer based sealant; firestops dynamic construction joints, through penetrations, static construction joints, and blank openings. Non-paintable. VOC (volatile organic content) of <32 g/L.

3M Fire Barrier Sealant CP 25WB+: High-performance, one-component, gun-grade, latex-based, intumescent sealant. Paintable, firestops and seals single or multiple through penetrations, blank openings, and static construction joints. Not acceptable for use with CPVC pipe. VOC (volatile organic content) of <1 g/L.

3M Fire Barrier Water Tight Sealant 3000WT: High-performance, one-component, neutral cure, intumescent silicone sealant. Fully cured acts as barrier to water leakage, repairable, firestops single and multiple through penetrations, bottom-of-wall static construction joints, blank openings, VOC (volatile organic content) of <31 g/L.

Provide 3M Ultra GS Wrap Strip where required by the through penetration assembly.

PART 3: EXECUTION

Proper Surfaces: Material in contact with sealant shall be dry, full cured, and free of laitance, loose aggregate, form release agents, curing compounds, water repellents and other surface treatment that would be detrimental to adhesion of sealant.

Masonry shall be cleaned and joints raked to proper depth to receive back-up and sealant.

Concrete shall be finished joints cleaned and fins removed.

Curing: Joints in masonry, concrete and stucco work shall not be sealed until substrate has cured minimum of 28 days.

PREPARATION:

Joint Cleaning: Clean all joints thoroughly, and blow out or vacuum loose particles from joints. Surfaces with protective coatings (such as aluminum) shall be wiped with xylol or methyl ethyl ketone solvent to remove protective coatings and oil deposits.

Sheet Metal: New sheet metal shall be wiped down with copper sulphate solution or with strong acetic acid solution to etch the zinc coating and remove oil and foreign matter from surface.

Joint Design: Coordinate work of other trades so that shape of joint, dimensions, and anticipated movement shall conform to following: (Comply with manufacturer's joint design requirements)

Minimum Width: Opening not less than 1/4" wide.

Minimum Depth: Opening not less than 1/8" deep.

Maximum Movement: The width of the opening shall be at least 4 times its maximum movement.

Width Depth Ratio: Comply with manufacturer's joint design requirements. Unless otherwise required, the depth of the sealant shall be no greater than the width. Depth should be more than 1/8" and not more than 1/2" deep, unless otherwise required by manufacturer.

All caulking joints shall be recessed openings. "Fillet" type caulking into corners will not be acceptable.

Joint Packing: Packing shall be installed in all joints to receive sealant. Packing shall be sized to require 20% to 50% compression upon insertion, and placed in accordance with "Joint Design" paragraph. (In joints not of sufficient depth to allow packing, install polyethylene bond-breaking tape at back of joint). Avoid lengthwise stretching of packing material.

Masking: Apply masking tape where required to protect adjacent surfaces. Adhere tape in continuous strips in alignment with joint edge, and remove immediately after joints have been sealed and tooled.

INSTALLATION:

Application of sealants shall be as recommended by Sealant Manufacturer. Work shall be done with standard handguns or mechanical guns. Extrude sealant through nozzles of such diameter as to allow full bead of material to run into joint, but not to exceed width of joint. Force sealant into joint by tooling to insure full contact with sidewalls and backing.

Locations: Use sealants in locations hereinbefore specified for joints as specified.

Joint Finishing: Unless otherwise indicated, all joints in horizontal surfaces shall be finished flush, all joints in vertical surfaces shall be finished slightly concave in shape. Use tooling stick or knife to strike off excess material, and properly shape bead. Use xylol or toluene to prevent sealant from adhering to tooling stick. Finished bead shall be smooth, even, and free from all wrinkling, air pockets, and foreign matter.

Install expansion joint filler as recommended by Manufacturer. Filler shall be size recommended by Manufacturer for use in the expansion joint erected and shall be installed with special tool and adhesive-lubricant.

CLEAN-UP:

Excess Material: Remove all excess material adjacent to joint by mechanical means and/or with solvent (such as xylol or toluol). Leave work in neat and workmanlike manner.

END OF SECTION

RELATED DOCUMENTS:

Drawings and general provisions of Contract, including General and Supplementary Conditions and Division-1 Specification sections, apply to work of this section.

PART 1: GENERAL

DESCRIPTION OF WORK:

Work required under this Section consists of providing galvanized hollow metal doors, frames, transoms, mullions, view window frames, and related items necessary to complete work indicated on Drawings and described in these specifications. Provide galvanized steel doors and frames for all openings where reasonably inferable from plan drawings, whether specifically scheduled and detailed or not.

INDUSTRY STANDARDS:

For listing of names of industry standard agencies mentioned by abbreviation in this Section refer to Section 01068.

Hollow Metal Manufacturers Association, HMMA

QUALITY ASSURANCE:

Manufacturers: Except as otherwise specified herein, all hollow metal doors and frames shall be products of one of following manufacturers, or an equal approved by Architect. Manufacturers shall be certified members of the Hollow Metal Manufacturers Association, HMMA. All doors and frames shall be from the same manufacturer.

- Amweld Bldg. Prod. Div.
- Ceco Corp.
- Curries Company
- Acme Steel Door Corporation
- Pioneer Fireproof Door Co.
- Steelcraft Mfg. Co.

SUBMITTALS:

Shop Drawings: Submit shop drawings, in accordance with GENERAL CONDITIONS, of all items specified herein to Architect for approval. Obtain approval of Drawings prior to proceeding with manufacturing. Shop drawings shall indicate following: elevations of each door type; details of each frame type; location in building for each item; conditions at openings with various wall thicknesses and materials; typical and special details of construction; methods of assembling sections; location and installation requirements for hardware; size, shape and thickness of materials; anchorage; joints and connections; and any additional pertinent information.

General Contractor shall field verify all door and frame sizes, door and frame prep requirements, and hardware prep requirements prior to fabrication.

Samples: Sample of door section indicating edge, top and/or bottom construction, insulation, hinge reinforcement and face stiffening. Sample of frame section showing welded corner joints, welded hinge reinforcements, dust covers and face finish.

PART 2: PRODUCTS

GALVANIZED METAL FRAMES: Except where otherwise scheduled, all frames for doors, shall be formed of galvanized steel to sizes and shapes indicated, to include but not limited to double and single rabbett frame profiles where indicated. Frames shall be combination type with integral trim and fabricated with full welded unit type construction at joints.

Type and Gauges of Metal: Metal for frames shall be commercial quality, cold-rolled, galvanized steel sheets, with clean smooth surfaces conforming to ASTM A 366. Except where other gauges are indicated or specified, frames shall be fabricated from steel, not lighter than following U.S. Standard gauges:

- Exterior frames - 14 gauge
- Interior frames to 3-0 in width - 16 gauge (generally)
- Interior frames over 3-0 in width - 14 gauge

Metal Reinforcements: Provide concealed metal reinforcements for hardware as required. Gauge of metal for reinforcement shall be in accordance with manufacturer's recommendations for type of hardware and the thickness and width of doors to be hung in frame, provided gauges used are not lighter than following:

- Hinge and pivot reinforcements - 7 gauge, 1-1/4"x 10" min. size.
- Strike reinforcements - 12 gauge.
- Flush bolt reinforcements - 12 gauge.
- Closer reinforcements - 12 gauge.
- Surface-mounted hardware reinforcements - 12 gauge.

Workmanship and Design: Finished work shall be strong and rigid, neat in appearance, and free from defects. Fabricate molded members straight and true, with corner joints well formed and in true alignment, and with fastenings concealed where practicable.

Forming Corner Joints: Joints for welded type frames shall be mitered and continuously arc-welded for full depth and width of frame and trim. All contact edges shall be closed tight and all welds on exposed surfaces dressed smooth and flush.

Provisions for Hardware: Wood doors shall be solid core, prefitted. Prepare frames at factory for installation of hardware. Frames shall be mortised, reinforced, drilled and tapped to templates to receive all mortised hardware; frames to receive surface-applied hardware shall be provided with reinforcing plates only. Where concealed overhead door closers are required in frame members, provide necessary additional space, cutouts, reinforcement and provisions for fastenings in heads of frames to receive closers. Provide cover boxes in back of all hardware cutouts. Punch doorframes to receive rubber door silencers; provide three (3) silencers on lock side of single doorframes and one silencer for each leaf in heads of double doorframes.

Wall Anchors: Provide metal anchors of shapes and sizes required for adjoining type of wall construction. Fabricate jamb anchors of steel, not lighter than gauge used for frame. Locate anchors on jambs near top and bottom of each frame and at intermediate points not over 24" apart.

For frames set in masonry provide 10" long, corrugated or other deformed type adjustable anchors at jambs, 4 per jamb.

For frames set in metal stud partitions weld jamb anchor clips to back of frames at jamb. Make provision for securing anchors to steel studs with 1/4" round-head machine screws, nuts and washers, or by welding. Furnish 4 anchors per jamb.

Floor Anchors: Provide floor clips of not less than 16-gauge steel and fasten to bottom of each jamb member for anchoring frame to floor construction. Clips shall be fixed and drilled for 3/8" diameter anchor bolts.

Shipment: Provide temporary steel spreaders fastened across bottom of frames; where construction will permit concealment, leave spreader in place after installation; otherwise remove spreaders after frames are set and anchored.

GENERAL REQUIREMENTS FOR GALVANIZED METAL DOORS:

Type and Gauges of Metal: Metal for doors shall be commercial quality, leveled, cold-rolled, galvanized steel sheets with clean, smooth surfaces, conforming to ASTM A 366-68. All units shall be galvanized. Gauges of face sheets shall be as specified for door types.

Hardware Reinforcements: Doors shall be mortised, reinforced, drilled and tapped at factory for fully templated hardware only, in accordance with approved hardware schedule and templates provided by Hardware Contractor. Where surface-mounted hardware is to be applied, doors shall have reinforcing plates only; all drilling and tapping shall be done by others. Steel doors for locksets shall have welded box reinforcements.

All hardware furnished by Hardware Supplier for single-acting doors shall be designed for beveled edges as specified.

Edge Profiles shall be provided on lock stiles of doors as follows:

- Single-acting swing doors - beveled 1/8" in 2".
- Opposite swing double doors - beveled 1/8" in 2".

Provide clearances as follows:

Between doors and frames; at head and jambs - 1/8".

At doorsills; where no threshold is scheduled - 3/8" maximum. Allow for carpet height where required.

At doorsills; where threshold is scheduled - 1/4" maximum between door bottom and threshold.

Between meeting stiles of pair of doors - 1/8".

Workmanship: Finish work shall rigid, neat in appearance, and free from defects. Form molded members straight and true, with joints coped or mitered, well formed, and in true alignment. All welded joints on exposed surfaces shall be dressed smooth so that they are invisible after finishing.

GALVANIZED FLUSH DOORS:

Construction: Construct doors of two outer steel sheets not lighter than 18 gauge, with edges welded and finished flush. Seams or joints will not be permitted on door faces or edges. Reinforce the outer face sheets with 20-gauge interlocking vertical channels of Z-shaped members spaced not over 6" apart and spot-welded to outer face sheets. All doors shall have galvanized steel faces and rails.

Cap tops of exterior doors to prevent the accumulation of water.

Reinforcement: Provide continuous reinforcing channels welded to face sheets at top and bottom of door. Place cork, fiberboard, or mineral wool board in spaces between reinforcing channels.

Moldings shall be not lighter than 18-gauge steel. Doors shall be prepared to receive hardware specified under HARDWARE Section.

Optional Construction: Continuous truss-formed inner core of sheet metal, not lighter than 28-gauge, may be substituted for reinforcing specified, provided it is spot-welded to face sheets every 2-3/4" horizontally and vertically over entire surface of both sides.

APPROVED FIRE DOORS AND FRAMES:

Provide approved hollow metal fire doors and frames at locations indicated in Door Schedule. Approved doors, frames and hardware shall be constructed and installed in accordance with requirements of Underwriter's Laboratories for Class of door opening indicated or specified.

Fire doors and frames which bear Underwriter's label for class of opening indicated will be only basis of acceptance.

SHOP PAINTING / GALVANIZING:

All interior and exterior doors and all interior and exterior frames shall be galvanized.

Apply primed finish to all galvanized metal surfaces furnished in this Section.

Clean and chemically treat metal surfaces to assure maximum paint adherence; follow with dip or spray coat of rust-inhibitive metallic oxide, zinc chromate, or synthetic resin primer on all exposed surfaces.

Finish surfaces shall be smooth and free from irregularities and rough spots.

Approved primer shall be compatible with finish coats specified in Section 09900.

LOCATION OF HARDWARE: Location of hardware for hollow metal doors and frames shall be as specified in Section 08700.

PART 3: EXECUTION

ERECTION:

Hollow metal shall be erected by skilled workers. Frames shall be carefully plumbed and aligned. Trim and glazing stops shall be coped or mitered with hairline fit. Brace frames until permanent anchors are set. Anchor bottoms of frames to floor with expansion bolts or with power fasteners.

In application of glazing beads, or other trim parts, exercise care to avoid running screws or other fasteners tightly enough to dimple metal.

Minor damage to metal, incurred during erection, may be repaired by filling with lead or lead alloy ground smooth and flush, if strength and appearance of finish work are not impaired, and if Architect approved. Otherwise, furnish new material.

PROTECTION AND CLEANING:

Protect doors and frames from damage during transportation and at job site. Store at site under cover on wood blocking or on suitable floors.

After installation, protect doors and frames from damage during subsequent construction activities.

Damaged work will be rejected and shall be replaced with new work.

Upon completion, metal surfaces of doors and frames shall be thoroughly cleaned, ready for paint finish by others.

END OF SECTION

RELATED DOCUMENTS:

Drawings and general provisions of Contract, including General and Supplementary Conditions and Division-1 Specification sections, apply to work of this section.

PART I: GENERAL

DESCRIPTION OF WORK:

Work of this Section shall include furnishing, delivering, and storing where directed at site, the following:

Solid Core Wood Doors, as shown on drawings and specified herein. Intent of drawings and specifications is to provide all wood doors for the entire project as indicated on plans, whether specifically scheduled or not. Provide wood doors for all openings where reasonably inferable from plan drawings.

INDUSTRY STANDARDS:

For listing of names of industry standard agencies mentioned by abbreviation in this Section refer to Section 01068.

SUBMITTALS:

Submit complete schedule indicating dimensions, cutouts, hardware sets, species, and other pertinent data, which references the individual architectural door mark number as shown on the plan sheets.

General Contractor shall field verify all door and frame sizes, door and frame prep requirements, and hardware prep requirements prior to fabrication.

Submit Manufacturer's data sheets, completely describing door construction, WDMA I.S. 1-A (formerly NWWDA) and AWI Classifications.

Door Supplier to submit written certification on the supplier's letterhead that the doors provided shall conform to every aspect of this specification.

Door physical finish samples shall accompany submittals. The samples will show the range of color variation.

Warranty statement shall accompany the submittal.

QUALITY ASSURANCE:

Flush wood veneer doors shall conform to the latest edition of the following standards: WDMA I.S. 1-A requirements for "Premium Grade".

Tolerances for warp, telegraphing, squareness, and prefitting dimensions as per the latest editions of WDMA I.S. 1-A, AWI Section 1300 and NFPA 80 1-11.4, 1999 edition.

Each door shall bear an identifying label indicating the manufacturer, door number and order number, as well as fire rating where applicable.

Where fire rated doors are required, provide doors labeled by ITS/Warnock Hersey International. Construction details and hardware application shall be as approved by the labeling agency.

Provide doors to meet UBC 7-2-1997 requirements for positive pressure opening assemblies in areas where this has been adopted by local authorities having jurisdiction.

MANUFACTURERS:

Standards: For purposes of designating type and quality for work under this Section, Drawings and Specifications are based on 5-ply door products meeting WDMA I.S. 1-A Premium Grade manufactured or furnished by Marshfield Door Systems.

Acceptable Manufacturers: Products of following manufacturers, meeting all requirements of these specifications, will also be acceptable.

- Marshfield
- Eggers Doors
- Oshkosh
- Algoma
- VT Industries

Samples: Sample corner section of door indicating edge, top/and/or bottom construction, core and hardware reinforcement.

Color Samples: Provide physical color samples in the veneer species specified, in the full range of manufacturer's standard colors.

Certificates: Provide certificate from manufacturer stating compliance with these specifications.

Guarantee: Provide guarantee for life of installation. Any defects noted during warranty period shall be corrected at no cost to the building Owner. Such corrective work shall include all labor and material for repair, replacement, refinishing and rehangng as required.

PRODUCT HANDLING:

Storage: Store doors at site so as to raise edges off floor and away from walls, letting air circulate freely. Store in enclosed area free from excessive heat, cold and humidity. Do not install scratched, dented or otherwise damaged doors in work.

Packaging: Door Manufacturer shall package doors in a manner to provide protection until they are installed.

Coordination: Provide Door Manufacturer with following:

- Two (2) copies of approved door schedule and Shop Drawings.
- Two (2) copies of the approved hardware schedule.
- One (1) copy of floor plan of building, showing Architect's marks and opening identification.
- Two (2) sets of templates for applicable locks, hinges and other finish hardware.

PART 2: PRODUCTS

SOLID CORE DOORS:

Construction: Doors shall be flush type, solid core, 5-ply, Premium Grade, Type PC-5ME. Seven-ply and non-bonded core construction not accepted. Doors shall be 1-3/4" thick and shall be widths and height shown on door schedule. All doors between use areas and corridors and all smoke doors shall be 20 minute fire rated unless required to be of higher rating.

Veneer: Face veneer to be plain sliced red oak, "A" grade, book and running matched, factory finished.

Finish: Doors to be factory stained and prefinished, delivered to job in protective wrapping. No doors shall be hung until finish work is complete.

Top and bottom rails shall be factory sealed with an approved sealer.

Core shall be of one piece slab, particle board, density 28-32 lb. per cu. ft. or greater bonded to stiles and rails with Type II adhesive, using high frequency method, then sanded as a unit. Meet particleboard standard ANSI A208.1, Grade 1-LD-2.

Vertical stiles shall be two piece 1 3/8" thick, with an inner stile of SCL laminated to outer 1/4" hardwood stile, matching the veneer, to provide minimum thickness after trimming of 1 3/8". Top and bottom rails shall be of structural composite lumber (SCL) construction 1 3/8" thick before prefitting. Blocking shall be provided where mortise closers or other similar devices occur.

Composite cross bands shall be applied to core prior to application of matching hardwood stiles. Exposed cross banding is not allowed along stile edges.

Veneers are to be applied to the cross banded core in a HOT PRESS using Type I exterior water resistant adhesive. Five ply construction. Exposed veneer edges are not permitted.

Openings: Factory cut openings for glass. Flush wood glass stops required for non-rated openings, species to match veneer. 20 minute rated glass kits will utilize concealed metal glass retaining clips equal or similar to VT Industries VT Fire Clip.

Glass: 1/4" tempered glass, impact resistant as required, will be furnished and installed as per Section 08800.

COMPOSITE FIRE DOORS:

Grade: WDMA I.S. 1-A, Premium, Type FD-5

Construction shall conform to Underwriter's Laboratories Class "B" 1 Hr. and 1-1/2 Hr. and Class "C" 3/4 Hr. rating requirements and shall have been tested in accordance with ASTM E 152 for fire resistance, heat transmission, and structural integrity.

Core: Core shall be calcium silicate with non-asbestos fibers, 30.8 – 34.7 lbs./ft³ nominal density, containing no asbestos. Core shall be jointed together with tongue-and-groove joints in accordance with Underwriter's Laboratories, Inc. procedure manual. Core shall be smoothly sanded prior to application of cross band and face veneer.

Edge Bands: Outer stiles are to be of same species as veneer. Inner stiles to be structural composite lumber (SCL) for 45 minute rated doors, or GP Firestop I for 60 and 90 minute rated doors which can be warranted for use with mortise butt hinges and No. 12 – 1 1/4" steel threaded-to-head screws. The door manufacturer shall drill 5/32" diameter pilot holes for all hinges.

Rails are to be structural composite lumber (SCL) for 45 minute rated doors, or GP Firestop for 60 and 90 minute rated doors, manufacturer's standard width.

Composite cross bands shall be applied to core prior to application of matching hardwood stiles. Exposed edge banding is not allowed along stile edges.

Veneers are to be applied to the cross banded core in a HOT PRESS using Type I exterior water resistant adhesive. Five ply construction. Exposed veneer edges are not permitted.

Where UBC 7-2-1997 requirements for positive pressure must be met, doors shall include all requirements as part of the door construction per "Category A" guidelines as published by ITS/Warnock Hersey. No intumescent is allowed on the frame. Only smoke gasketing applied around the perimeter of the frame to meet the "S" rating is permissible.

Vision panels and glass lights where indicated on plans, furnish and install vision panels glazed with 1/4" tempered or wire glass as indicated. Glass stops will be flush type and will utilize concealed metal glass retaining clips equal or similar to VT Industries VT Fire Clip. Where UBC 7-2-1997 requirements for positive pressure must be met, install a light kit labeled for UBC 7-2-1997 positive pressure applications to meet the appropriate fire rating.

Astragal sets, metal edges, or edge guards will not be allowed on positive pressure doors concealing intumescent within door structure.

FACTORY FINISHING:

AWI, catalyzed polyurethane, premium grade. Stain coat, three coats of sealer, two polyurethane topcoats finish per AWI Section 1500. AWI Types 2 and 3 are not acceptable.

Top and bottom rails shall be factory sealed.

HARDWARE PREPARATION:

Machining: Doors shall be factory machined for application of finish hardware that required cutting of door (except surface applied hardware) including pilot holes for hinge screws and lock fronts.

Coordination: Door manufacturer shall assume responsibility of properly coordinating hardware schedule, door schedule, and hollow metal frame shop drawings and shall supply machined doors individually identified for proper openings.

LOCATION OF HARDWARE: Refer to Section 08700.

PART 3: EXECUTION

CONDITION OF SURFACES:

Frames shall be set plumb and secure before installation of doors.

Responsibility: Contractor will be held responsible for correct door frame installation. Frames out of square, cocked at bottom or bowed in or out along vertical jambs more than 1/8" shall be reinstalled.

Temperature and Humidity: Doors shall not be installed until areas of installation have temperature and humidity near that of completed building.

DOOR INSTALLATION:

Fire door installation is required to be in accordance with the NFPA 80, "Standard for Fire Doors and Fire Windows". Machined fire doors shall be provided with detailed installation instructions when doors bear a label indicating compliance to UBC 7-2-1997 or UL 10C.

Hanging: Doors shall be fitted, hung plumb, and true to within following allowable warpage tolerances: 1/4" for doors of areas 10 sq. ft. or greater, 1/8" for doors under area of 10 sq. ft. Install fire doors in accordance with NFPA Pamphlet 80 1-11.4, 1999 edition and U.L. requirements.

Non-rated clearances: Provide clearances of 1/8" at sides and top; lock edge shall have required bevel to clear frame. Provide at bottom, for specific locations, minimum adequate clearance of finish floor coverings and/or thresholds, not to exceed 3/4". Provide other undercuts as required.

Category "A" clearances between door edge and frame must be at least 1/16" and no greater than 1/8" at the head and jambs. See NFPA 80 1-11.4, 1999 edition, for clearance under door bottoms.

Factory machined doors improperly sized for opening or improperly machined for hardware by Door Manufacturer shall be rejected and returned to factory for proper replacement.

GLAZING:

Set glass against fixed molding with specific glazing compound utilizing glass retaining clips as specified.

END OF SECTION

RELATED DOCUMENTS:

Drawings and general provisions of Contract, including General and Supplementary Conditions and Division-1 Specification sections, apply to work of this section.

PART 1: GENERAL

RELATED DOCUMENTS

Section 08418 Aluminum Storefront Framing
Section 08700 Door Hardware

DESCRIPTION OF WORK

The extent of each type of door and frame is shown on the Drawings and Schedules.

The following types of doors and frames are required:

1. SL-17 FRP fiberglass/aluminum flush doors, with 2" x 4 1/2" Aluminum thermally broken frames
2. FRP panels and mid rail panels
3. Door hardware

SYSTEM PERFORMANCE

Provide door assemblies that have been designed and fabricated to comply with requirements for system performance characteristics listed below and as indicated on Drawings, as demonstrated by testing manufacturer's corresponding standard systems according to test methods designated.

Thermal Transmission (exterior doors): "U" value of not more than 0.09 (BTU/Hr. x sf x degrees F.) per AAMA 1503.01.

NFPA 80-16: Standard for fire Doors and Other Opening Protectives.

UL 10B: Standard for Fire Tests of Door Assemblies

UL 10C: Standard for Positive Pressure Fire Tests of Door Assemblies

NFPA 252: Fire Tests of Door Assemblies

Flame Spread/Smoke Developed: Provide FRP doors and panels with the following ratings in according with ASTM E 84: Flame Spread: Not greater than 170 (Class C). Smoke Developed: Not greater than 390 (Class C).

Class A option for flame spread and smoke developed rating on interior faces of exterior panels and both faces of interior panel as shown. Flame spread no greater than 15, smoke developed no greater than 310 per ASTM E-84.

Additional Criteria: Provide FRP doors and panels with the following performance: ASTM D 256 \bar{D} nominal value of 20.0 ASTM D 570 \bar{D} nominal value of .20 to .40% ASTM D 2583 \bar{D} nominal value of 50

Abrasion Resistance: Face sheet to have no greater than .029 average weight loss percentage after Taber Abrasion Test \bar{D} 25 cycles at 500 gram weight with H-18 wheel.

Stain Resistance: Face sheet to be unaffected after 24 hour exposure to SVS-1 white spray enamel. Must retain DE of .57 or less with MacBeth Colorimeter. Dark Brown (Bronze) FRP to be used as a basis.

Chemical Resistance: Face sheet to be unaffected after 4 hour exposure to acetic acid (10% solution), acetone, sodium hypochlorite (5.25% solution) and hydrochloric acid (10% solution). No discoloration or panel damage will be allowed.

QUALITY ASSURANCE

Standards: Comply with the requirements and recommendations in applicable specification and standards by AAMA, except to the extent more stringent requirements are indicated.

References:

- A. [AAMA 1304](#) – Voluntary Specification for Forced Entry Resistance of Side-Hinged Door Systems.
- B. [AAMA 1503-98](#) – Thermal Transmittance and Condensation Resistance of Windows, Doors and Glazed Wall Sections.
- C. [ANSI A250.4](#) – Test Procedure and Acceptance Criteria for Physical Endurance of Steel Doors and Hardware Reinforcing.
- D. [ASTM-B117](#) – Standard Practices for Operating Salt Spray (Fog) Apparatus.
- E. [ASTM-B209](#) – Standard Specification for Aluminum and Aluminum-Alloy Sheet and Plate.
- F. [ASTM-B221](#) – Standard Specification for Aluminum-Alloy Extruded Bars, Rods, Wire, Profiles, and Tubes.
- G. [ASTM-C518](#) – Standard test Method for Steady-State Thermal Transmission Properties by Means of Heat Flow Meter Apparatus.
- H. [ASTM-D256](#) – Standard Test Methods for Determining the Pendulum Impact Resistance of Plastics.
- I. [ASTM-D570](#) – Standard Test Method for Water Absorption of Plastics.
- J. [ASTM-D638](#) – Standard Test Method for Tensile Properties of Plastics.
- K. [ASTM-D790](#) – Standard Test Methods for Flexural Properties of Unreinforced and Reinforced Plastics and Electrical Insulating Materials.
- L. [ASTM-D1621](#) – Standard Test Method for Compressive Properties of Rigid Cellular Plastics.
- M. [ASTM-D1622](#) – Standard Test Method for Apparent Density of Rigid Cellular Plastics.
- N. [ASTM-D1623](#) – Standard Test Method for Tensile and Tensile Adhesion Properties of Rigid Cellular Plastics.
- O. [ASTM-D2126](#) – Standard Test Method for Response of Rigid Cellular Plastics to Thermal and Humid Aging.
- P. [ASTM-D2583](#) – Standard Test Method for Indentation Hardness of Rigid Plastics by Means of a Barcol Impressor.
- Q. [ASTM-D3029](#) – Test Methods for Impact Resistance of Flat Rigid Plastic Specimens by Means of a Tup (Falling Weight) (Withdrawn 1995) (Replaced by ASTM-D5420).
- R. [ASTM-D5116](#) – Standard Guide for Small-Scale Environmental Chamber Determinations of Organic Emissions from Indoor Materials/ Products.
- S. [ASTM-D5420](#) – Standard Test Method for Impact Resistance of Flat, Rigid Plastic Specimen by Means of a Striker Impacted by a Falling Weight (Gardner Impact).
- T. [ASTM-D6670](#) – Standard Practice for Full-Scale Chamber Determination of Volatile Organic Emissions from Indoor Materials/ Products.
- U. [ASTM-E84](#) – Standard Test Method for Surface Burning Characteristics of Building Materials.
- V. [ASTM-E90](#) – Standard Test Method for Laboratory Measurement of Airborne Sound Transmission Loss of Building Partitions.
- W. [ASTM-E283](#) – Standard Test Method for Determining Rate of Air Leakage Through Exterior Windows, Curtain Walls, and Doors Under Specified Pressure Differences Across the Specimen.
- X. [ASTM-E330](#) – Standard Test Method for Structural Performance of Exterior Windows, Curtain Walls, and Doors by Uniform Static Air Pressure Difference.

- Y. [ASTM-E1886](#) – Standard Test Method for Performance of Exterior Windows, Curtain Walls, Doors and Storm Shutters Impacted by Missile(s) and Exposed to Cyclic Pressure Differentials.
- Z. [ASTM-E1996](#) – Standard Specification for Performance of Exterior Windows, Glazed Curtain Walls, Doors and Storm Shutters Impacted by Wind Borne Debris in Hurricanes.
- AA. [ASTM-F476](#) – Standard Test Methods for Security of Swinging Door Assemblies.
- BB. [ASTM-F1642-04](#) – Standard Test Method for Glazing Systems Subject to Air Blast Loading.
- CC. [NWWDA T.M. 7-90](#) – Cycle Slam Test Method.
- DD. [NFRC 100](#) – Procedure for Determining Fenestration Products U-Factors.
- EE. [NFRC 400](#) – Procedure for Determining Fenestration Products Air Leakage.
- FF. [TAS 201](#) – Impact Test Procedures.
- GG. [TAS 202](#) – Criteria for Testing Impact & Nonimpact Resistant Building Envelope Components Using Uniform Static Air Pressure.
- HH. [TAS 203](#) – Criteria for Testing Products Subject to Cyclic Wind Pressure Loading.

Performance: A minimum ten (10) year record of production of frames, doors and panels and completion of similar projects in type and size.

Instruction: The manufacturer or his representative will be available for consultation to all parties engaged in the project including instruction to installation personnel.

Field Measurement: Field verify all information prior to fabrication and furnishing of materials. Furnish and install materials omitted due to lack of verification at no additional cost to owner.

Regulation and Codes: Comply with the current edition in force at the project location of all local, state and federal codes and regulations, including the Americans with Disabilities Act of 1992.

SYSTEM PERFORMANCE

- A. Completed assemblies shall comply with all current NC Building code requirements.
- B. All test unit sizes and configurations shall conform to: Florida High Velocity Hurricane Zone (HVHZ) Protocols, ICC Compliant ASTM E 1886, ASTM E 1996, all requirements of TAS 201, TAS 202, and TAS 203.
- C. Door and Aluminum Tube Frame Assembly.
 - 1. Physical Endurance, ANSI A250.4: 25,000,000 Cycles, No Damage.
 - 2. Salt Spray, ASTM-B117: 500 hours minimum exposure.
 - 3. Air Leakage, NFRC 400, ASTM-E283.
 - a. Opaque Swinging Door (< than 50% glass)
 - 1. 0.01 cfm/sqft @ 1.57 psf.
 - 2. 0.01 cfm/sqft @ 6.24 psf.
 - b. Commercially Glazed Swinging Entrance Door (> than 50% glass)
 - 1. 0.38 cfm/sqft @ 1.57 psf.
 - 2. 0.73 cfm/sqft @ 6.24 psf.
 - 4. Structural Performance, ASTM E-330.
 - a. Single or Pair of Doors, 8'4" x 8'2" overall size, single point latching.
 - 1. ± 75 psf design pressure, pass.
 - 5. Impact and Cycle Test, ASTM-E1886.
 - a. Single or Pair of Doors, 6'8" x 7'8" overall size, 3-point latching.
 - 1. 9 lbs. missile @ 50 fps, minimum 3 impacts, no rips, tears, or penetrations.
 - 2. ± 75 psf design pressure, pass.
 - 6. Forced Entry, AAMA 1304.
 - a. Single or Pair of Doors, 6'8" x 7'8" overall size, 3-point latching.

1. 300lb Pull Test, pass.
 7. Impact Test, TAS 201.
 - a. Single or Pair of Doors, 6'8" x 7'8" overall size, 3-point latching.
 1. 9 lbs. missile @ 50 fps, minimum 3 impacts, no rips, tears, or penetrations.
 8. Static Air Pressure, TAS 202.
 - a. Single or Pair of Doors, 6'8" x 7'8" overall size, 3-point latching.
 1. ± 65 psf design pressure, pass.
 2. Forced Entry, 300lb Pull Test, pass.
 9. Cyclic Wind Pressure Loading, TAS 203.
 - a. Single or Pair of Doors, 6'8" x 7'8" overall size, 3-point latching.
 1. ± 65 psf design pressure, pass.
 10. Security Test, ASTM-F476: Minimum Grade 40.
 11. Blast Test, ASTM-F1642.
 - a. 6 psi @ 45 psi-msec, minimal hazard, operable.
- D. Door and Thermally Broken Aluminum Frame Assembly.
1. Thermal Transmittance, NFRC 100.
 - a. Opaque Swinging Door (< than 50% glass)
 1. U-Factor = 0.31 Btu/hr-ft²·°F.
 - b. Commercially Glazed Swinging Entrance Door (> than 50% glass)
 1. U-Factor = 0.64 Btu/hr-ft²·°F.
 2. Air Leakage, NFRC 400, ASTM-E283.
 - a. Opaque Swinging Door (< than 50% glass)
 1. 0.01 cfm/sqft @ 1.57 psf.
 2. 0.01 cfm/sqft @ 6.24 psf.
 - b. Commercially Glazed Swinging Entrance Door (> than 50% glass)
 1. 0.38 cfm/sqft @ 1.57 psf.
 2. 0.73 cfm/sqft @ 6.24 psf.
 3. Sound Transmission, ASTM-E90: STC = 30, OITC = 29.
- E. Door and AF-150 Frame Assembly.
1. Thermal Transmittance, NFRC 100.
 - a. Opaque Swinging Door (< than 50% glass)
 1. U-Factor = 0.32 Btu/hr-ft²·°F.
 - b. Commercially Glazed Swinging Entrance Door (> than 50% glass)
 1. U-Factor = 0.57 Btu/hr-ft²·°F.
 2. Air Leakage, NFRC 400, ASTM-E283.
 - a. Opaque Swinging Door (< than 50% glass)
 1. 0.12 cfm/sqft @ 1.57 psf.
 2. 0.06 cfm/sqft @ 6.24 psf.
 - b. Commercially Glazed Swinging Entrance Door (> than 50% glass)
 1. 0.04 cfm/sqft @ 1.57 psf.
 2. 0.14 cfm/sqft @ 6.24 psf.
- F. Door and Hollow Metal Steel Frame.
1. Cycle Slam, NWWDA T.M. 7-90.
 - a. 5,000,000 cycles.
 1. No Operational Damage.
 2. No Hinge Separation.

SUBMITTALS

Product Data: Submit Manufacturers product data, specifications and instructions for each type of door and frame required in accordance with Section 01340 and the following:

1. Include details of core, stile and rail construction, trim for lites and all other components.
2. Include details of finish hardware mounting.
3. Include samples of each aluminum alloy to be used on this project. Where normal finish color and texture variations are expected, include two or more samples to show the range of such variations.
4. Include one sample of typical fabricated section, showing joints, fastenings, quality of workmanship, hardware and accessory items before fabrication of the work proceeds.
5. Product Data and details: Concealed proximity reader
6. Physical color samples

Testing and Evaluation Reports.

Submit testing reports and evaluations provided by manufacturer conducted by and accredited independent testing agency certifying doors and frames comply with specified performance requirements listed

Submit Shop Drawings for the fabrication and installation of the doors and frames, and associated components. Details to be shown full scale. Include glazing details and finish hardware schedule.

PRODUCT DELIVERY, STORAGE AND HANDLING

Deliver materials to job site in their original, unopened packages with labels intact. Inspect materials for damage and advise manufacturer immediately of any unsatisfactory materials.

Package door assemblies in individual corrugated cartons so no portion of the door has contact with the outer shell of the container. Package and ship frames preassembled to the greatest possible extent.

PROJECT GUARANTEE

Provide a written guarantee signed by manufacturer, installer and contractor, agreeing to replace, at no cost to the owner, any doors, frames or factory hardware installation which fail in materials or workmanship, within the guarantee period. Failure of materials or workmanship includes: excessive deflection, faulty operation of entrances, deterioration of finish or construction in excess of normal weathering and defects in hardware installation. The minimum time period of guarantee is ten (10) years from acceptance.

PART 2: PRODUCTS

DOORS

Manufacturer: Subject to compliance with requirements, provide products of the following:

1. SL-17 flush FRP/aluminum door with SpecLite3E as manufactured by Special-Lite, Inc., Decatur, Michigan.

MATERIALS AND ACCESSORIES

Aluminum Members: Alloy and temper as recommended by manufacturer for strength, corrosion resistance and application of required finish and control of color; ASTM B 221 for extrusions, ASTM B 209 for sheet/plate with aluminum wall thickness of 0.1259.

Components: Furnish door and frame components from the same manufacturer.

Splitting of door and frame components is not permitted.

Fasteners: Aluminum, non-magnetic stainless steel or other non-corrosive metal fasteners, guaranteed by the manufacturer to be compatible with the doors, frames, stops, panels, hardware, anchors and other items being fastened. For exposed fasteners (if any) provide Phillips head screws with finish matching the item to be fastened.

Glazing Gaskets: For glazing factory-installed glass, and for gaskets which are factory-installed in Captive assembly of glazing stops, manufacturers standard stripping of molded neoprene, complying with ASTM D 2000 (designation 2BC415 to 3BC620), or molded PVC complying with ASTM C 509 Grade 4

Weather stripping: Manufacturer's standard pile type in replaceable rabbets for stiles; manufacturer's standard EPDM bulb type in doorframes.

Hardware:

ADA Compliant:

- a. Hardware as scheduled on drawings and specified in 08700 unless otherwise noted herein
- b. Aluminum Threshold: Pemko 2005AV, or equivalent by National Guard or Hagar.
- c. Continuous exterior mounted door sweep with drip – Pemko 345-V, or equivalent.
- d. Push/Pull unless exit device indicated on Door Schedule.
- e. Closer: LCN 4040XP, with backstop arm, with prefinished metal cover.
- f. Heavy-Duty 4 ½" Ball-Bearing Butt Hinges: Hager, Stanley, McKinney
- g. Removable mullion at pairs of doors: Von Duprin, keyed operation.

FABRICATION

Sizes and Profiles: The required sizes for door and frame units, and profile requirements are shown on the drawings.

Coordination of Fabrication: Field measure before fabrication, and show recorded measurements on final shop drawings.

Complete the cutting, fitting, forming, drilling and grinding of all metal work prior to assembly.

Remove burrs from cut edges, and ease edges and corners to a radius of approximately 1 /649.

No welding of doors or frames is acceptable.

Maintain continuity of line and accurate relation of planes and angles. Secure attachments and support at mechanical joints, with hairline fit at contacting members.

FIBERGLASS REINFORCED POLYESTER FRP FLUSH DOORS

Materials and Construction:

1. Construct SL-17 1 3/4" thickness doors of 6063-T5 aluminum alloy stiles and rails minimum 2 5/16" depth. Construct with mitered corners and provide joinery of 3 /89 diameter full width tie rods through extruded splines top and bottom as standard .1259 tubular shaped stiles and rails reinforced to accept hardware as specified. Provide hex type aircraft nuts for joinery without welds, glues or other methods for securing internal door extrusions. Furnish integral reglets to accept face sheet to permit a flush appearance. Rail caps or other face sheet capture methods are not acceptable.
2. Extrude top and bottom rail legs for interlocking continuous rigidity weather bar. Lock face sheet material in place with extruded interlocking edges to be flush with aluminum stiles and rails.
3. Door FRP face sheeting: .1209 thickness pebble grain fiberglass reinforced polyester. SL-17 flush doors with an abuse resistant engineered surface of the standard colors: to be selected from manufacturers standard selection, minimum selection as follows: white, light gray, red, blue, green, beige, dark gray, dark bronze, black.

12" Mid-rail panel FRP face sheeting: .1209 thickness fiberglass reinforced polyester. Colors: to be selected from manufacturers standard selections,: white, light gray, red, blue, green, beige, dark gray, dark bronze, black.
 - a. Standard Interior and Exterior Class C 0.120" thick, pebble texture, through color with SpecLite 3® integral surfaseal film FRP sheet.
 - b. Flexural Strength, ASTM-D790: 21 x 103 psi.
 - c. Flexural Modulus, ASTM-D790: 0.7 x 106 psi.
 - d. Tensile Strength, ASTM-D638: 13 x 103 psi.
 - e. Tensile Modulus, ASTM-D638: 1.2 x 106 psi.
 - f. Barcol Hardness, ASTM-D2583: 55.
 - g. Izod Impact, ASTM-D256: 14.0 ft-lb/in.
 - h. Gardner Impact Strength, ASTM-D5420: 120 in-lb.
 - i. Water Absorption, ASTM-D570: 0.20%/24hrs at 77°F.
 - j. Surface Burning, ASTM-E84: Flame Spread ≤ 200, Smoke Developed ≤ 450.
 - k. Taber Abrasion Resistance, Taber Test: 0.007% Max Wt. Loss, cs-17 wheels, 1000g. Wt., 25 cycles.
 - l. Chemical Resistance.
 - m. Excellent Rating.
 - n. Acetic Acid, Concentrated.
 - o. Acetic Acid, 5%.
 - p. Bleach Solution.
 - q. Detergent Solution.
 - r. Distilled Water.
 - s. Ethyl Acetate.
 - t. Formaldehyde.
 - u. Heptane.
 - v. Hydrochloric Acid, 10%.
 - w. Hydrogen Peroxide, 3%.
 - x. Isooctane.
 - y. Lactic Acid, 10%.
4. Core of Door Assembly: Minimum five pounds per cubic foot density poured-in-place polyurethane free of CFC. Minimum 'R' value of 11. Ballistic rating is as indicated. Meeting stiles on pairs of doors and bottom weather bar with nylon brush weather stripping.

5. Manufacture doors with cutouts for glass vision lites, louvers or FRP panels as scheduled. Factory furnish and install all glass, louvers and panels prior to shipment.
6. Pre-machine doors in accordance with templates from the specified hardware manufacturers and approved hardware schedule, including built-in and concealed Electronic Access Control devices. Factory install hardware and devices.

LOUVERS

Special-Lite inverted 'Y' louver, clear anodized.

FRAMING SYSTEMS

Aluminum Tubular Framing:

1. Thermally broken framing system 2" x 4 ½" from the door manufacturer of the size and type shown on Drawings, widths to match adjacent 4 ½" aluminum storefront framing sizes, with .1259 minimum wall thickness and type 6063-T5 aluminum alloy. .6259 high applied doorstops with screws and weather stripping. Frame members are to be box type with four (4) enclosed sides. Open back framing will not be acceptable.
2. Caulk joints before assembling frame members. Secure joints with fasteners and provide a hairline butt joint appearance. Prefit doors to frame assembly at factory prior to shipment. Field fabrication of framing using Stick material is not acceptable.
3. Applied stops for side, transom and borrowed lites and panels, with fasteners exposed on interior or unsecure portion only. Pre-machine and reinforce frame members for hardware in accordance with manufacturer's standards and the approved hardware schedule.
4. Install with anchors appropriate for wall conditions to anchor framing to wall materials. A minimum of five anchors up to 7849 on jamb members, and one additional anchor for each foot over 7849. Secure head and sill members of transom, side lites and similar conditions.
5. Factory pre-assemble side lites to the greatest extent possible, and mark frame assemblies according to location.

GLAZING

Design system for Glass:

1. Manufacturers standard flush glazing system of recessed channels and captive glazing gaskets or applied stops as shown.
2. Allow for thermal expansion on exterior units.
3. Provide glass as specified in 08800 and shown, factory glazed into doors.

FINISHES

Anodized Surfaces: Clear, Class I, 0.7 mils.

PART 3: EXECUTION

INSTALLATION

Comply with manufacturers recommendations and specifications for the installation of the doors and frames. Factory install hardware, glass and louvers in doors. Factory assemble side lites and transoms to the greatest extent possible.

Set units plumb, level and true to line, without warp or rack of doors or frames. Anchor securely in place. Separate aluminum and other metal surfaces with bituminous coatings or other means as approved by architect.

Set thresholds in a bed of mastic and backseal.

Clean surfaces promptly after installation of doors and frames, exercising care to avoid damage to the protective coatings.

Ensure that the doors and frames will be without damage or deterioration (other than normal weathering) at the time of acceptance.

Provide owner with all adjustment tools and instruction sheets. Arrange an inservice session to owner at owner's convenience. Provide a minimum one-year written guarantee on all labor related to this section. Any workmanship, which is defective or deficient, shall be corrected to the owner's satisfaction and at no additional cost to the owner.

END OF SECTION

RELATED DOCUMENTS:

Drawings and general provisions of Contract, including General and Supplementary Conditions and Division-1 Specification sections, apply to work of this section.

PART 1 - GENERAL

DESCRIPTION OF WORK:

Work of this Section shall be to provide rolling shutters at all areas indicated on Drawings and specified in this Section.

1. Stainless steel rolling counter shutters at the Food Service Area by the FOOD SERVICE CONTRACTOR.
2. Overhead-coiling security grille at the Kitchen by GENERAL CONTRACTOR.

RELATED SECTIONS:

Section 11200 Kitchen Equipment

INDUSTRY STANDARDS:

For listing of names of industry standard agencies mentioned by abbreviation in this Section, refer to Section 01068.

QUALITY ASSURANCE:

Manufacturers:

Standard: For purpose of designating type and quality for work under this Section, Drawings and Specifications are based on products fabricated by Cookson. Other listed Manufacturer's who can furnish similar products or systems of same materials specified, will also be acceptable.

SUBMITTALS:

Manufacturer's Data: Submit for approval three (3) copies of folder containing complete Manufacturer's data and installation procedures for all products to be used in work of this Section.

Shop Drawings: Submit Shop Drawings in compliance with GENERAL CONDITIONS. These drawings shall be coordinated with work of Kitchen Equipment Contractor.

PRODUCT HANDLING:

Working Areas: Provide suitable areas for storage of materials and equipment.

Delivery: Deliver products to site in original sealed containers or packages bearing Manufacturer's name and brand designation.

PART 2 - PRODUCTS

STAINLESS STEEL ROLLING METAL COUNTER SHUTTER:

Provide the stainless steel rolling metal counter shutter for the kitchen tray return (by FOOD SERVICE CONTRACTOR), as shown on the Drawings and specified in this Section and Section 11200.

Provide stainless steel counter shutter with push up operation, all stainless steel construction, Cookson Model CD10-SS.

Curtain: To be formed of 22 gauge Stainless Steel flat-faced Midget Slats (Cookson Slat No. 10). Width of slats 1 1/4". Depth of crown 1/2". Bottom bar shall be tubular in shape and provided with double vinyl astragal.

Barrel: Curtain to be coiled around a steel tubing of not less than 4" diameter. Counter balancing unit to be enclosed and shall rotate on grease sealed ball bearings.

Counter Balance: Shall consist of oil-tempered torsion springs capable of counter balancing weight of curtain.

Operation: Curtain shall be of push-up operation with finger lifts mounted in the bottom bar.

Guides: To be fabricated from Stainless Steel shapes.

Locking Device: Bottom bar of curtain shall be furnished with a concealed sliding bolt deadlock operated by a thumb knob.

Hood: Stainless Steel of 24 gauge minimum thickness shall be furnished as necessary to encase curtain roll.

Finish: All stainless steel to be #4 finish.

OVERHEAD COILING SECURITY GRILLE:

Overhead-coiling security grilles, 674 Series Overhead Coiling Grilles by Overhead Door Corporation.

Curtain: Horizontal 5/16 diameter rods with network of vertically interlocking links to form a pattern. Bottom bar shall be a double angle stainless steel shape.

1. Material: Clear Anodized Aluminum.
2. Vertical Rod Spacing: 2 inches on center.
3. Horizontal Link Spacing: 9 inches on center.
4. Pattern: Straight lattice.

Finish: Components shall have the following finish.

1. All non-galvanized, exposed ferrous surfaces shall receive one coat of rust-inhibitive primer and top coats of finish paint per Section 09900 Paint.
2. Grille Curtain: Clear anodized aluminum

Guides: Clear anodized shapes with retainer grooves with continuous silicone treated wool-pile strips or PVC inserts to reduce noise and assist operation.

Ceiling Grilles Closures: Clear anodized aluminum to match grille

Brackets: Minimum 3/16" black powder coat finish steel to structure for support of barrel, counterbalance and hood.

Counterbalance: Helical torsion spring type. Counterbalance shall be housed in a steel tube or pipe barrel, supporting the curtain with deflection limited to 0.03 per foot of span. Counterbalance shall be adjustable by means of an adjusting tension wheel.

Hood: Clear anodized aluminum, 24 gauge hood with intermediate supports as required, for installation above ceiling.

Electric Motor Operation: Provide UL listed electric operator, size as recommended by manufacturer to move door in either direction at not less than 2/3 foot nor more than 1 foot per second.

1. Sensing Edge Protection: Electric sensing edge
2. Operator Controls: Key operated controls station with open, close, and stop buttons for flush mounting, for interior location.
3. Emergency Egress Device: Interior flush mounted handle mechanism to automatically open grille part way to permit passage even if power is not available.

Provide electric door operators of size and capacity recommended for security grilles as provided by grille manufacturer, with minimum 1/2 HP electric motor and factory pre-wired motor controls equal to (standard duty) ArmorDrive modular door control system as manufactured by Overhead Door Corporation.

Electric operator shall incorporate automatic emergency egress, compliant with IBC 1008.1.4 & NFPA 101.

Provide powertrain suitable for type and size of door, featuring starters, planetary gear-reduction unit, electromagnetic disc brake, clutch, remote-controlled stations, control devices, and all necessary accessories for proper operation and a complete assembly.

Provide motor operator mounting kit, for installation above ceiling, suitable for the type and size of door specified.

Locking: Cylinder lock keyed to match school's master keying system.

Framing:

Guides face and jamb mounted on adjacent wall construction, and included vertical pipe column supports..

Supports: Provide free standing heavy-duty vertical tubular steel support pipe frames supplied with grilles for flush with wall surface guide installations, arranged per Drawing requirements.

PART 3 - EXECUTION

INSPECTION

Examine all surfaces to which products are scheduled to be installed. If unsatisfactory conditions exist, report to General Contractor and do not proceed with work until conditions have been satisfactorily corrected.

INSTALLATION:

All installations shall be performed by capable workmen under direction of foreman fully qualified by experience in each respective field of installation work.

END OF SECTION

RELATED DOCUMENTS:

Drawings and general provisions of Contract, including General and Supplementary Conditions and Division-1 Specification sections, apply to work of this section.

PART 1: GENERAL

1.01 SUMMARY

- A. Section Includes: Aluminum Swing Doors, including:
 - 1. YKK AP Series 50D Wide Stile Swing Entrances.
- B. Related Sections:
 - 1. Glass and Glazing: Refer to Division 8 Glass and Glazing Section for glass and glazing requirements.

1.02 SYSTEM PERFORMANCE DESCRIPTION

- A. Completed assemblies shall comply with all current NC Building code requirements.
- B. Performance Requirements: Provide aluminum swing doors that comply with performance requirements indicated, as demonstrated by testing manufacturers assemblies in accordance with test methods indicated.
 - 1. Air Infiltration (Single Acting Butt Hinges or Offset Pivots): Air infiltration shall be tested in accordance with ASTM E 283 at static pressure of 1.57 PSF (75 Pa). Infiltration shall not exceed the following:
 - a. Pair of Doors: 0.18 CFM/FT (1.02 m³/h·m) of crack length.
 - b. Single Doors: 0.50 CFM/FT (2.84 m³/h·m) of crack length.
 - 2. Structural: Door corner structural strength test using a dual moment loading criteria as follows:
 - a. A representative corner section consisting of a 12 inch top rail and a 24 inch long stile.
 - b. Top rail of each section is anchored to a fixed surface at 3 inches from corner joint; a load arm was subsequently mounted at 19 inches from inside edge of top rail on suspended side rail.
 - c. A load was applied to the load arm at 19 inches from inside edge of side rail and amount of rotation of load arm observed. Process was repeated at increasing loads until point of failure defined as greater than 45 degrees rotation of load arm occurred.
 - d. Test results shall be supported by an independent laboratory test report, as follows:
 - i. YKK AP Model: 50D Swing Door; 300 lbs.

3. Structural Uniform Load Test:
 - a. Single Doors: 90 psf.
 - b. Pair of Doors: 90 psf.
4. Forced Entry Resistance: 300 lbs. satisfactory.

1.03 PROJECT CONDITIONS / SITE CONDITIONS

- A. Field Measurements: Verify actual measurements/openings by field measurements before fabrication: show recorded measurements on shop drawings. Coordinate field measurements, fabrication schedule with construction progress to avoid construction delays.

1.04 SUBMITTALS

- A. General: Prepare, review, approve, and submit specified submittals in accordance with "Conditions of the Contract" and Division 1 Submittals Sections. Product data, shop drawings, samples, and similar submittals are defined in "Conditions of the Contract."
- B. Product Data: Submit product data for each entrance series specified
- C. Shop Drawings: Submit shop drawings showing layout, profiles, and product components, including anchorage, accessories, and finish colors.
- D. Samples: Submit verification samples for colors. Minimum 2-1/2 inch by 3 inch (61 mm by 73 mm) samples on actual aluminum substrates indicating full color range expected in installed system.
- E. Quality Assurance / Control Submittals:
 1. Test Reports: Submit certified test reports showing compliance with specified performance characteristics and physical properties.
 2. Installer Qualification Data: Submit installer qualification data.
- F. Closeout Submittals:
 1. Warranty: Submit executed warranty documents specified herein, endorsed by YKK AP authorized official and installer.
 2. Project Record Documents: Submit project record documents, including operation and maintenance data for installed materials in accordance with Division 1 Project Closeout (Project Record Documents) Section.
 - a. Maintenance Data: Maintenance procedures for care and cleaning of entrance systems.

PART 2: PRODUCTS

2.01 MANUFACTURERS (Acceptable Manufacturers/Products)

- A. Entrance Door Acceptable Manufacturers:
 1. YKK AP America Inc., Austell, GA 30168, Telephone: (678) 838-6000

2. Old Castle Model Equivalent
 3. Tubelite Standard Wide Stile Entrances
- B. Aluminum Storefront Entrance Door Products:
1. Wide Stile Swing Doors: YKK AP Series 50D Wide Stile Swing Doors with 6" mid-rail.
 - a. Description: 5" Door Stile
 2. Corner Construction: Fabricate door corners joined by concealed reinforcement secured with screws, and sigma deep penetration welding.
 3. Glazing Stops: Manufacturer's standard snap-in glazing stops with EPDM glazing gaskets to prevent water infiltration.
 4. Weather stripping: Manufacturer's standard pile type in replaceable rabbets for stiles; manufacturer's standard EPDM bulb type in doorframes.
- C. Hardware: ADA Compliant:
- a. Aluminum Threshold: Pemko 2005AV, or equivalent by National Guard or Hager.
 - b. Weather stripping – perimeter wool pile: National Guard, Pemko, or Hager.
 - c. Continuous door sweep with drip – Pemko 345-V, or equivalent.
 - d. Push/Pull unless exit device indicated on Door Schedule.
 - e. Closer: LCN 4040XP, with backstop arm, with prefinished metal cover.
 - f. Heavy-Duty 4 ½" Ball-Bearing Butt Hinges: YKK, Hager, Stanley, McKinney
 - g. Removable mullion at pairs of doors: Von Duprin; keyed operation.

2.02 MATERIALS

- A. Extrusions: ASTM B 221 (ASTM B 221M), 6063-T5 Aluminum Alloy.
- B. Aluminum Sheet:
1. Anodized Finish: ASTM B 209 (ASTM B 209M), 5005-H14 Aluminum Alloy, 0.050 inch (1.27 mm) minimum thickness.
 2. Painted Finish: ASTM B 209 (ASTM B 209M), 3003-H14 Aluminum Alloy, 0.080 inch (1.95) mm) minimum thickness.

2.03 ACCESSORIES

- A. Manufacturer's Standard Accessories:
1. Fasteners: Zinc plated steel concealed fasteners; Hardened aluminum alloys or AISI 300 series stainless steel exposed fasteners, countersunk, finish to match aluminum color.

2. Sealant: Non-skinning type, AAMA 803.3.
3. Glazing: Setting blocks, edge blocks, and spacers in accordance with ASTM C 864, shore durometer hardness as recommended by manufacturer; Glazing gaskets in accordance with ASTM C 864.

2.04 RELATED MATERIALS (Specified In Other Sections)

- A. Glass: Refer to Division 8 Glass and Glazing Section for glass materials.

2.05 FABRICATION

- A. Shop Assembly: Fabricate and assemble units with joints only at intersection of aluminum members with uniform hairline joints; rigidly secure, and sealed in accordance with manufacturer's recommendations.

1. Hardware: Drill and cut to template for hardware. Reinforce frames and door stiles to receive hardware in accordance with manufacturer's recommendations.
2. Welding: Conceal welds on aluminum members in accordance with AWS recommendations or methods recommended by manufacturer. Members showing welding bloom or discoloration on finish or material distortion will be rejected.

- B. Fabrication Tolerances:

1. Material Cuts: Square to 1/32 inch (0.8 mm) off square, maximum, over largest dimension; proportionate amount of 1/32 inch (0.8 mm) on other two dimensions.
2. Maximum Offset: 1/64 inch (0.4 mm) in alignment between two consecutive members in line, end to end.
3. Maximum Offset: 1/64 inch (0.4 mm) between framing members at glazing pocket corners.
4. Joints (Between adjacent members in same assembly): Hairline and square to adjacent member.
5. Variation (In squaring diagonals for doors and fabricated assemblies): 1/16 inch (1.6 mm).
6. Flatness (For doors and fabricated assemblies): +/- 1/16 inch (1.6 mm) off neutral plane.

2.06 FINISHES AND COLORS

- A. Anodized Finish: YKK AP AMERICA Anodized Finish

1. Clear Anodized (MATCH EXISTING) with clear protective composite coating.

- B. Finishing: Prepare aluminum surfaces for specified finish; apply shop finish in accordance with the following:

1. Anodized Coating: Electrolytic color coating followed by an organic seal applied in accordance with the requirements of AAMA 612-02. Aluminum extrusions shall be produced from quality-controlled billets meeting AA-6063-T5.

- a. Exposed surfaces shall be free of scratches and other serious blemishes.

- b. Extrusion shall be given a caustic etch followed by an anodic oxide treatment and sealed with an organic electrodeposition applied protective top coating.
 - c. The anodized coating shall comply with all the requirements of AAMA 612-02; Voluntary Specifications, Performance Requirements and Test Procedures for Combined Coatings of Anodic Oxide and Transparent Organic Coatings on Architectural Aluminum. Testing shall demonstrate the ability of the finish to resist damage from mortar, salt spray, and chemicals commonly found on construction sites, and to resist the loss of color and gloss.
 - d. Overall coating thickness for finishes shall be a minimum of 0.7 mils.
- C. Finishes Testing:
- 1. Apply 0.5% solution NaOH, sodium hydroxide, to small area of finished sample area; leave in place for sixty minutes; lightly wipe off NaOH; Do not clean area further.
 - 2. Submit samples with test area noted on each sample.
- D. Anodized Finish Warranty: 10-year warranty commencing on Date of Substantial Completion.

PART 3: EXECUTION

3.01 MANUFACTURER'S INSTRUCTIONS / RECOMMENDATIONS

- A. Compliance: Comply with manufacturer's product data, including product technical bulletins, product catalog installation instructions, and product carton instructions.

3.02 EXAMINATION

- A. Site Verification of Conditions: Verify conditions (which have been previously installed under other sections) are acceptable for product installation in accordance with manufacturer's instructions.
 - 1. Verify location of preset anchors, perimeter fasteners, and block-outs are in accordance with shop drawings.

3.03 PREPARATION

- A. Adjacent Surfaces Protection: Protect adjacent work areas and finish surfaces from damage during product installation.
 - 1. Aluminum Surface Protection: Protect aluminum surfaces from contact with lime, mortar, cement, acids, and other harmful contaminants.

3.04 INSTALLATION

- A. General: Install manufacturer's system in accordance with shop drawings, and within specified tolerances.
 - 1. Protect aluminum members in contact with masonry, steel, concrete, or dissimilar materials using nylon pads or bituminous coating.
 - 2. Shim and brace aluminum system before anchoring to structure.

3.05 FIELD QUALITY CONTROL

- A. Manufacturer's Field Services: Upon Owner's request, provide manufacturer's field service consisting of product use recommendations and periodic site visit for inspection of product installation in accordance with manufacturer's instructions.

3.06 ADJUSTING AND CLEANING

- A. Adjusting: Adjust swing doors for operation in accordance with manufacturer's recommendations.
- B. Cleaning: The General Contractor shall clean installed products in accordance with manufacturer's instructions prior to owner's acceptance, and remove construction debris from project site. Legally dispose of debris.
- C. Protection: The General Contractor shall protect the installed product's finish surfaces from damage during construction.

END OF SECTION

RELATED DOCUMENTS:

Drawings and general provisions of Contract, including General and Supplementary Conditions and Division-1 Specification sections, apply to work of this section.

PART 1: GENERAL

1.01 SUMMARY

A. Section Includes: Aluminum Storefront Systems

1. YKK AP Series YES 45F-T MegaTherm™ Storefront System 2" x 4 ½".
2. Glass and glazing.
3. Perimeter trims.
4. Sills, extruded aluminum sub-sills, with end dams and weeps.
5. Brake Metal sill pan flashing
6. All installation hardware and accessories required for a secure installation.
7. Shims, plates and anchors required for a secure installation.
8. Perimeter sealing.

B. Related Sections:

1. Sealants: Refer to Division 7 Joint Treatment Section for sealant requirements.
2. Glass and Glazing: Refer to Division 8 Glass and Glazing Section for glass and glazing requirements.

1.02 SYSTEM DESCRIPTION

A. Completed assemblies shall comply with all current NC Building code requirements.

B. Performance Requirements: Provide aluminum storefront systems that comply with performance requirements indicated, as demonstrated by testing manufacturer's assemblies in accordance with test method indicated.

1. Wind Loads: Completed storefront system shall withstand wind pressure loads normal to wall plane indicated:
 - a. Exterior Walls:
 1. Positive Pressure:
 2. Negative Pressure:
 - b. Interior Walls (Pressure Acting in Either Direction):
2. Deflection: Maximum allowable deflection in any member when tested in accordance with ASTM E 330-84 with allowable stress in accordance with AA Specifications for Aluminum Structures.
 - a. Without Horizontals: L/175 or 3/4" (19.1mm) maximum.
 - b. With Horizontals: L/175 or L/240 + 1/4" (6.4mm) for spans greater than 13'-6" (4.1m) but less than 40'-0" (12.2m).

3. Thermal Movement: Provide for thermal movement caused by 180 degrees F. (82.2 degrees C.) surface temperature, without causing buckling stresses on glass, joint seal failure, undue stress on structural elements, damaging loads on fasteners, reduction of performance, or detrimental effects.
4. Air Infiltration: Completed storefront systems shall have 0.00 CFM/FT² (0.00 m³/h·m²) maximum allowable infiltration when tested in accordance with ASTM E 283-84 at differential static pressure of 6.24 PSF (299 Pa).
5. Water Infiltration: No uncontrolled water on indoor face of any component when tested in accordance with ASTM E 331-86 at a static pressure of 15 PSF (718 Pa).
6. Watertight Installations: Field Tested in accordance with AAMA 501.2-03.
7. Thermal Performance: When tested in accordance with AAMA 1503.1-88 Condensation Resistance Factor (CRF), and ASTM C 236-89 Thermal Transmittance (U Value) as follows:
 - a. CRF: A minimum of 59.
 - b. U Value: 0.58 BTU/HR/FT²/°F or less.

1.03 SUBMITTALS

- A. General: Prepare, review, approve, and submit specified submittals in accordance with "Conditions of the Contract" and Division 1 Submittals Sections. Product data, shop drawings, samples, and similar submittals are defined in "Conditions of the Contract."
- B. Product Data: Submit product data for each type storefront series specified.
- C. Shop Drawings: Submit shop drawings showing layout, profiles, and product components, including anchorage, accessories, finish colors and textures.
- D. Samples: Submit verification samples for colors on actual aluminum substrates indicating full color range expected in installed system.
 1. Typical framing member
 2. Extruded aluminum subsill with weeps and end dams
 3. Bent plate sill pan
- E. Quality Assurance / Control Submittals:
 1. Test Reports: Submit certified test reports showing compliance with specified performance characteristics and physical properties.
 2. Installer Qualification Data: Submit installer qualification data.
- F. Closeout Submittals:
 1. Warranty: Submit warranty documents specified herein.
 2. Project Record Documents: Submit project record documents for installed materials in accordance with Division 1 Project Closeout (Project Record Documents) Section.

1.04 QUALITY ASSURANCE

- A. Qualifications:
 - 1. Installer Qualifications: Installer experienced (as determined by contractor) to perform work of this section who has specialized in the installation of work similar to that required for this project. If requested by Owner, submit reference list of completed projects.
 - 2. Manufacturer Qualifications: Manufacturer capable of providing field service representation during construction, approving acceptable installer and approving application method.
- B. Pre-Installation Meetings: Conduct pre-installation meeting to verify project requirements, substrate conditions, manufacturer's installation instructions, and manufacturer's warranty requirements.
- C. Mock-Ups (Field Constructed): Install at project site a job mock-up using acceptable products and manufacturer approved installation methods. Obtain Owner's and Architect's acceptance of finish color, and workmanship standard.
- D. Maintenance: Maintain mock-up during construction for workmanship comparison; remove and legal dispose of mock-up when no longer required.
- E. Incorporation: Mock-up may be incorporated into final construction upon Owner's approval.
- F. Field Test: Conduct field test to determine water-tightness of storefront system. Conduct test in accordance with AAMA 501.2-03 at locations selected by Architect.

1.05 PROJECT CONDITIONS / SITE CONDITIONS

- A. Field Measurements: Verify actual measurements/openings by field measurements before fabrication; show recorded measurements on shop drawings. Coordinate field measurements, fabrication schedule with construction progress to avoid construction delays.

1.06 WARRANTY

- A. Project Warranty: Refer to "Conditions of the Contract" for project warranty provisions.
- B. Manufacturer's Warranty: Submit, for Owner's acceptance, manufacturer's standard warranty document executed by authorized company official. Manufacturer's warranty is in addition to, and not a limitation of, other rights Owner may have under the Contract Documents.
 - 1. Beneficiary: Issue warranty in the legal name of the project Owner.
 - 2. Warranty Period: 5 years commencing on Date of Substantial Completion
 - 3. Warranty Acceptance: Owner is sole authority who will determine acceptability of manufacturer's warranty documents.
 - 4. Anodized Finish Warranty: 10-year warranty commencing on Date of Substantial Completion.

PART: 2 PRODUCTS

2.01 MANUFACTURERS (Acceptable Manufacturers/Products)

A. Acceptable Manufacturers:

YKK AP America Inc., Austell, GA 30168, Telephone: (678) 838-6000

1. Storefront System: YKK AP YES 45F-T MegaTherm™ Storefront System.

Oldcastle FG-3000T
US Aluminum Series IT 451

B. Storefront Framing System:

1. Description: Center set, exterior flush glazed; jambs and vertical mullions continuous; head, sill, intermediate horizontal attached by screw spline joinery.
2. Components: Manufacturer's standard extruded aluminum mullions, 0-15 degree hinged mullions, 90 degree corner posts, flexible corner posts, three-way corner posts, entrance door framing, and indicated shapes.
3. Thermal Barrier: Provide continuous thermal barrier by means of 6/6 nylon polyamide glass fiber reinforced pressure extruded bars. Systems employing non-structural thermal barriers are not acceptable.
4. Provide extruded aluminum sub-sill with weeps and integrally formed end dams at exterior storefront systems. Profiles, sizes and shape as indicated on Drawings.
5. Doorstops to be integral fin type, snap-in type not acceptable.
6. Provide internal frame reinforcements all closer locations.

2.02 MATERIALS

A. Extrusions: ASTM B 221 (ASTM B 221M), 6063-T5 Aluminum Alloy.

B. Aluminum Sheet:

1. Anodized Finish: ASTM B 209 (ASTM B 209M), 5005-H14 Aluminum Alloy, 0.050 inch (1.27 mm) minimum thickness.
2. Painted Finish: ASTM B 209 (ASTM B 209M), 3003-H14 Aluminum Alloy, 0.080 inch (1.95 mm) minimum thickness.

2.03 ACCESSORIES

A. Manufacturer's Standard Accessories:

1. Fasteners: Zinc plated steel concealed fasteners; Hardened aluminum alloys or AISI 300 series stainless steel exposed fasteners, countersunk, finish to match aluminum color.
2. Sealant: Non-skinning type, AAMA 803.3

3. Glazing: Setting blocks, edge blocks, and spacers in accordance with ASTM C 864, shore durometer hardness as recommended by manufacturer; Glazing gaskets in accordance with ASTM C 864.
4. Brake metal plate sill pan flashing with hemmed edges.
5. Aluminum flat plates as needed for anchoring; shims, plates and anchors required for a secure installation.

2.04 RELATED MATERIALS (Specified In Other Sections)

- A. Glass: Refer to Division 8 Glass and Glazing Section for glass materials.
- B. Metal Window Panels: Refer to Division 8 Glass and Glazing Section for metal panel materials.

2.05 FABRICATION

- A. Shop Assembly: Fabricate and assemble units with joints only at intersection of aluminum members with hairline joints; rigidly secure, and sealed in accordance with manufacturer's recommendations.
- B. Fabrication Tolerance:
 1. Material Cuts: Square to 1/32 inch (0.8 mm) off square, over largest dimension; proportionate amount of 1/32 inch (0.8 mm) on the two dimensions.
 2. Maximum Offset: 1/64 inch (0.4 mm) in alignment between two consecutive members in line, end to end.
 3. Maximum Offset: 1/64 inch (0.4 mm) between framing members at glazing pocket corners.
 4. Joints (Between adjacent members in same assembly): Hairline and square to adjacent member.
 5. Variation (In squaring diagonals for doors and fabricated assemblies): 1/16 inch (1.6 mm).
 6. Flatness (For doors and fabricated assemblies): +/- 1/16 inch (1.8 mm) off neutral plane.

2.06 FINISHES AND COLORS

- A. Anodized Finish: YKK AP AMERICA Anodized Finish
 1. Clear Anodized, with protective composite coating.
- B. Finishing: Prepare aluminum surfaces for specified finish; apply finish in accordance with the following:
 1. Anodized Coating: Electrolytic color coating followed by an organic top coating applied to aluminum extrusions produced from quality-controlled billets meeting AA-6063-T5.
 - a. Exposed surfaces shall be free of scratches and other serious blemishes.

- b. Extrusion shall be given a caustic etch followed by an anodic oxide treatment and sealed with an organic electrodeposition applied protective top coating.
- c. Overall coating thickness for finishes shall be a minimum of 0.7 mils.
- d. Coating shall conform to Aluminum Association Standard AAM12C22A4X. A4X designation shall signify an anodic coating of 0.4 mils minimum followed by an organic top coating of a minimum 0.3 mils.
- e. In addition to the Aluminum Association Standard above, finish shall conform to the following:
 - i. AAMA 605.2 Mortar Resistance Test Specification; Test Method per ASTM C207, 24 Hour Pat Test.
 - ii. CASS Corrosion Resistance Test. CASS 240/ASTM B368 Test Method.
 - iii. Other AAMA 605.2 Performance Tests specified in these specifications, such as: 7.3 Dry Film; 7.8.2 Salt Spray Resistance; 7.9.1.2 Color Retention, South Florida; 7.9.1.4 Gloss Retention, South Florida.

C. Finishes Testing:

- 1. Apply 0.5% solution NaOH, sodium hydroxide, to small area of finished sample area; leave in place for sixty minutes; lightly wipe off NaOH; Do not clean area further.
- 2. Submit samples with test area noted on each sample.

D. Anodized Finish Warranty: 10-year warranty commencing on Date of Substantial Completion.

PART 3: EXECUTION

3.01 MANUFACTURER'S INSTRUCTIONS / RECOMMENDATIONS

- A. Compliance: Comply with manufacturer's product data, including product technical bulletins, product catalog installation instructions, and product carton instructions.

3.02 EXAMINATION

- A. Site Verification of Conditions: Verify substrate conditions (which have been previously installed under other sections) are acceptable for product installation in accordance with manufacturer's instructions.

3.03 PREPARATION

- A. Adjacent Surfaces Protection: Protect adjacent work areas and finish surfaces from damage during product installation.

3.04 INSTALLATION

- A. General: Install manufacturer's system in accordance with shop drawings, and within specified tolerances.

1. Protect aluminum members in contact with masonry, steel, concrete, or dissimilar materials using nylon pads or bituminous coating.
2. Shim and brace aluminum system before anchoring to structure.
3. Provide brake metal sill pan flashings with hemmed edges at exterior storefront systems. Provide profiles, sizes and profiles as indicated on Drawings. Extend sill pan flashings continuous with spliced joints; set in continuous beds of waterproofing sealant.
4. Verify storefront system allows water entering system to be collected in gutters and weeped to exterior. Verify weep holes are open, and metal joints are sealed in accordance with manufacturer's installation instructions.
5. Seal metal-to-metal storefront system joints using sealant recommended by system manufacturer.
6. All installation hardware and accessories required for a secure installation into rough openings, including shims, plates and anchors as necessary.

3.05 FIELD QUALITY CONTROL

- A. Manufacturer's Field Services: Upon Owner's request, provide manufacturer's field service consisting of product use recommendations and periodic site visit for inspection of product installation in accordance with manufacturer's instructions.
- B. Field Test: Conduct field test to determine water-tightness of curtain wall system. Conduct test in accordance with AAMA 501.2-03 at locations selected by Architect.
- C. Perform minimum of three tests on various areas as determined by the Architect's representative. Perform test in Architect's presence. Field test first panels completed, then test all panels thereafter upon completion of all fixed panels. Generate and issue test report in compliance with AAMA 501.2-03 requirements.

3.06 ADJUSTING AND CLEANING

- A. Adjusting: Adjust operating items as recommended by manufacturer.
- B. Cleaning: The General Contractor shall clean installed products in accordance with manufacturer's instructions prior to Owner's acceptance, and remove construction debris from project site. Legally dispose of debris.
- C. Protection: The General Contractor shall protect installed product's finish surfaces from damage during construction.

END OF SECTION

RELATED DOCUMENTS:

Drawings and general provisions of Contract, including General and Supplementary Conditions and Division-1 Specification sections, apply to work of this section.

PART 1 - GENERAL

1.1 SUMMARY

- A. Section includes the 4" insulated translucent sandwich panel system and accessories as shown and specified. Work includes providing and installing:
 - 1. Flat factory prefabricated structural insulated translucent sandwich panels
 - 2. Aluminum clampite installation system
 - 3. Aluminum sill flashing

- B. Related Sections:
 - 1. Structural Steel Section 05120
 - 2. Unit Masonry Section 04200
 - 3. Flashing and Sheet Metal Section 07600
 - 4. Sealants Section 07900
 - 5. Glazing Section 08800
 - 6. Pre-Engineered Building Section 13120

1.2 SUBMITTALS

- A. Submit manufacturer's product data. Include construction details, material descriptions, profiles and finishes of components.

- B. Submit shop drawings. Include elevations and details.

- C. Submit manufacturer's color charts showing the full range of colors available for factory-finished aluminum.
 - 1. When requested, submit samples for each exposed finish required, in same thickness and material indicated for the work and in size indicated below. If finishes involve normal color variations, include sample sets consisting of two or more units showing the full range of variations expected.
 - a. Sandwich panels: 7" x 12" units
 - b. Factory finished aluminum: 3" long sections

- D. Submit Installer Certificate, signed by installer, certifying compliance with project qualification requirements.

- E. Submit product reports from a qualified independent testing agency indicating each type and class of panel system complies with the project performance requirements, based on comprehensive testing of current products. Previously completed reports will be acceptable if for current manufacturer and indicative of products used on this project.
 - 1. Reports required are:
 - a. International Building Code Evaluation Report
 - b. Flame Spread and Smoke Developed (UL 723) – Submit UL Card

- c. Burn Extent (ASTM D 635)
- d. Color Difference (ASTM D 2244)
- e. Impact Strength (UL 972)
- f. Bond Tensile Strength (ASTM C 297 after aging by ASTM D 1037)
- g. Bond Shear Strength (ASTM D 1002)
- h. Beam Bending Strength (ASTM E 72)
- i. Insulation U-Factor (NFRC 100)
- j. NFRC System U-Factor Certification (NFRC 700)
- k. Solar Heat Gain Coefficient (NFRC or Calculations)
- l. Condensation Resistance Factor (AAMA 1503)
- m. Air Leakage (ASTM E 283)
- n. Structural Performance (ASTM E 330)
- o. Water Penetration (ASTM E 331)
- p. Fire Penetration of Exterior Wall Assemblies Using a Direct Flame Impingement Exposure (ASTM E2707)

1.3 CLOSEOUT SUBMITTALS

- A. Provide field maintenance manual to include in project maintenance manuals.

1.4 QUALITY ASSURANCE

- A. Manufacturer's Qualifications
 - 1. Material and products shall be manufactured by a company continuously and regularly employed in the manufacture of specified materials for a period of at least ten consecutive years and which can show evidence of those materials being satisfactorily used on at least six projects of similar size, scope and location. At least three of the projects shall have been in successful use for ten years or longer.
 - 2. Panel system must be listed by an ANSI accredited Evaluation Service, which requires quality control inspections and fire, structural and water infiltration testing of sandwich panel systems by an accredited agency.
 - 3. Quality control inspections shall be conducted at least once each year and shall include manufacturing facilities, sandwich panel components and production sandwich panels for conformance with AC177 "Translucent Fiberglass Reinforced Plastic (FRP) Faced Panel Wall, Roof and Skylight Systems" as issued by the ICC-ES.
- B. Installer's Qualifications: Installation shall be by an experienced installer, which has been in the business of installing specified panel systems for at least two consecutive years and can show evidence of satisfactory completion of projects of similar size, scope and type.

1.5 PERFORMANCE REQUIREMENTS

- A. The manufacturer shall be responsible for the configuration and fabrication of the complete panel system.
 - 1. When requested, include structural analysis data signed and sealed by the qualified professional engineer responsible for their preparation.
 - 2. Standard panel system shall have less than 0.01 cfm/ft² air leakage by ASTM E 283 at 6.24 PSF at 50 mph and no water penetration by ASTM E 331 at 15 PSF; and structural testing by ASTM E 330.
 - 3. Structural Loads; Provide system capable of handling the following loads:
 - a. Wind Load: Basic Wind Speed 129 MPH 3-SEC Gusts (ASCE 7)
Exposure: C

Base Shears: $V_x = 79K$, $V_y = 71K$

- B. Deflection Limits:
 - 1. Walls: Limited to **L/60** of clear span for each assembly component.
- C. Thermal Movements: Allow for thermal movements from ambient- and surface-temperature changes. Base calculations on surface temperatures of materials due to both solar heat gain and nighttime-sky heat loss.
 - 1. Temperature Change (Range): 110 deg F (43 deg C), ambient; 150 deg F (66 deg C), material surfaces.

1.6 DELIVERY STORAGE AND HANDLING

- A. Deliver panel system, components and materials in manufacturer's standard protective packaging.
- B. Store panels on the long edge; several inches above the ground, blocked and under cover in accordance with manufacturer's storage and handling instructions.

1.7 WARRANTIES

- A. Submit manufacturer's and installer's written warranty agreeing to repair or replace panel system work, which fails in materials or workmanship within one year of the date of delivery. Failure of materials or workmanship shall include leakage, excessive deflection, deterioration of finish on metal in excess of normal weathering, defects in accessories, insulated translucent sandwich panels and other components of the work.
- B. 5 year Materials and Workmanship.
- C. Panel Warranties:
- D. Finish Warranty: 10 year Limited Warranty covering separation of faces from grid core, and/or abnormal color change of the exterior face.

PART 2 - PRODUCTS

2.1 MANUFACTURER

- A. The basis for this specification is for products manufactured by Kalwall Corporation. Other manufacturers may bid this project provided they comply with the substitution requirements of the AIA Instructions To Bidders, General Conditions, all of the performance requirements of this specification and submit evidence thereof.
- B. Kalwall Corporation, Tel: (800) 258-9777 – Email: info@kalwall.com

2.2 PANEL COMPONENTS

- A. Face Sheets
 - 1. Translucent faces: Manufactured from glass fiber reinforced thermoset resins, formulated specifically for architectural use.

- a. Thermoplastic (e.g. polycarbonate, acrylic) faces are not acceptable.
 - b. Face sheets shall not deform, deflect or drip when subjected to fire or flame.
2. Interior face sheets:
- a. Flame spread: Underwriters Laboratories (UL) listed, which requires periodic unannounced retesting, with flame spread rating no greater than 50 and smoke developed no greater than 450 when tested in accordance with UL 723.
 - b. Burn extent by ASTM D 635 shall be no greater than 1".
3. Exterior face sheets:
- a. Color stability: Full thickness of the exterior face sheet shall not change color more than 3 CIE Units DELTA E by ASTM D 2244 after 5 years outdoor South Florida weathering at 5° facing south, determined by the average of at least three white samples with and without a protective film or coating to ensure long-term color stability. Color stability shall be unaffected by abrasion or scratching.
 - b. Strength: Exterior face sheet shall be uniform in strength, impenetrable by hand held pencil and repel an impact minimum of 70 ft. lbs. without fracture or tear when impacted by a 3-1/4" diameter, 5 lb. free-falling ball per UL 972.
4. Appearance:
- a. Exterior face sheets: Smooth 0.070" thick and in color selected by the Architect from standard colors.
 - b. Interior face sheets: Smooth 0.045" thick and in color selected by the Architect from standard colors.
 - c. Face sheets shall not vary more than ± 10% in thickness and be uniform in color.
- B. Grid Core
1. Aluminum I-beam grid core shall be of 6063-T6 or 6005-T5 alloy and temper with provisions for mechanical interlocking of muntin-mullion and perimeter. Width of I-beam shall be no less than 7/16".
 2. I-beam Thermal break: Minimum 1", thermoset fiberglass composite.
- C. Laminate Adhesive
1. Heat and pressure resin type adhesive engineered for structural sandwich panel use, with minimum 25-years field use. Adhesive shall pass testing requirements specified by the International Code Council "Acceptance Criteria for Sandwich Panel Adhesives".
 2. Minimum tensile strength of 750 PSI when the panel assembly is tested by ASTM C 297 after two exposures to six cycles each of the aging conditions prescribed by ASTM D 1037.
 3. Minimum shear strength of the panel adhesive by ASTM D 1002 after exposure to four separate conditions:
 - a. 50% Relative Humidity at 68° F: 540 PSI
 - b. 182° F: 100 PSI
 - c. Accelerated Aging by ASTM D 1037 at room temperature: 800 PSI
 - d. Accelerated Aging by ASTM D 1037 at 182° F: 250 PSI

2.3 PANEL CONSTRUCTION

- A. Provide sandwich panels of flat fiberglass reinforced translucent face sheets laminated to a grid core of mechanically interlocking I-beams. The adhesive bonding line shall be straight, cover the entire width of the I-beam and have a neat, sharp edge.
 - 1. Thickness: 4 inches
 - 2. Grid Core Insulation: Fill panel cores with air.
 - 3. Panel U-factor by NFRC certified laboratory: Standard for 4" thermally broken aluminum grid.
 - 4. Grid pattern: Nominal size 12" h. x 24" w.
- B. Standard panels shall deflect no more than 1.9" at 30 PSF in 10' 0" span without a supporting frame by ASTM E 72.
- C. Panels shall meet the conditions of acceptance according to ASTM E2707 Fire Penetration of Exterior Wall Assemblies Using a Direct Flame Impingement Exposure:
 - 1. Absence of flame penetration through the wall assembly at any time.
 - 2. Absence of evidence of glowing combustion on the interior surface of the assembly at the end of the 60-min observation period.
 - 3. Absence of evidence of flame, glow, and smoke if the test is terminated prior to the completion of the 60-min observation period.
- D. Thermally broken panels: Minimum Condensation Resistance Factor of 80 by AAMA 1503 measured on the bond line.

2.4 ALUMINUM CLAMPTITE INSTALLATION SYSTEM

- A. Aluminum clamtite installation system:
 - 1. Thermally Broken-Flat extruded aluminum 6063-T6 and 6063-T5 alloy and temper clamtite screw type closure system.
- B. Sealing tape: Manufacturer's standard, pre-applied to aluminum clamtite installation system at the factory under controlled conditions..
- C. Fasteners: 300 series stainless steel screws for aluminum clamtite installation system, excluding final fasteners to the building.
- D. Finish:
 - 1. Anodized finish to match project exterior aluminum storefront framing anodized finish color.

PART 3 - EXECUTION

3.1 EXAMINATION

- A. Installer shall examine substrates, supporting structure and installation conditions.
- B. Do not proceed with panel installation until unsatisfactory conditions have been corrected.

3.2 PREPARATION

- A. Metal Protection:

1. Where aluminum will contact dissimilar metals, protect against galvanic action by painting contact surfaces with primer or by applying sealant or tape recommended by manufacturer for this purpose.
2. Where aluminum will contact concrete, masonry or pressure treated wood, protect against corrosion by painting contact surfaces with bituminous paint or method recommended by manufacturer.

3.3 INSTALLATION

- A. Install the panel system in accordance with the manufacturer's suggested installation recommendations and approved shop drawings.
 1. Anchor component parts securely in place by permanent mechanical attachment system.
 2. Accommodate thermal and mechanical movements.
 3. Set perimeter framing in a full bed of sealant compound, or with joint fillers or gaskets to provide weather-tight construction.
- B. Install joint sealants at perimeter joints and within the panel system in accordance with manufacturer's installation instructions.

3.4 FIELD QUALITY CONTROL

- A. Water Test: Installer to test a representative section of installed materials according to procedures in AAMA 501.2.
- B. Repair or replace work that does not pass testing or that is damaged by testing and retest work.

3.5 CLEANING

- A. Clean the panel system interior and exterior, immediately after installation.
- B. Refer to manufacturer's written recommendations.

END OF SECTION

RELATED DOCUMENTS:

The general provisions of the Contract, including General and Supplementary Conditions, and General Requirements, apply to the work specified in this Section.

PART 1: GENERAL

DESCRIPTION OF WORK:

Work of this Section shall include all labor, materials, equipment, transportation, tools and storage required for complete installation of all finish hardware shown and scheduled on Drawings and specified herein. Intent of this Specification is to provide complete finishing hardware requirements for entire building project excepting hardware, which is specifically mentioned hereinafter as being furnished by others. Any openings not specifically mentioned herein shall be furnished consistent with hardware specified for similar openings.

Wood doors for Project are prefitted. Coordinate with wood door manufacturer in furnishing hardware templates and schedules at earliest possible time.

INDUSTRY STANDARDS:

For listing of names of industry standard agencies mentioned by abbreviation in this section refer to Section 01068.

QUALITY ASSURANCE:

Manufacturers: Hardware listed in Hardware Schedule shall be supplied by one of following Manufacturers listed for each item or an equal. To establish quality of hardware required, catalog numbers of Manufacturers listed in Hardware Schedule have been used. Hardware furnished shall be of equal type, design, quality and function as that specified in Hardware Schedule.

Acceptable Manufacturers: Similar items manufactured or furnished by other manufacturers may be submitted for approval, subject to these Specification requirements, AIA A701, and written approval received 10 days prior to bid date.

Supplier's Qualifications: Contractor shall select only supplier who has in his employ qualified personnel, who shall manage and coordinate complete hardware contract, and shall also be available to visit Project in order to solve or correct conditions affecting proper hardware installation or adjustment, as required.

SUBMITTALS:

Schedule: Submit Hardware Schedule to Architect in six (6) copies, as promptly as possible, showing quantities, types, catalog numbers and locations of various items of finish hardware required. Submit as specified for shop drawings in accordance with GENERAL CONDITIONS.

Job Completion Instructions: At completion of work turn over to Owner all tools, instructions, and maintenance information for his use in maintaining hardware. Furnish Owner also with two copies of Job Use Finish Hardware Schedule for his permanent records.

PRODUCT HANDLING:

Packing, Marking and Labeling: Deliver hardware to project site in manufacturer's original packages. Each article of hardware shall be neatly wrapped and individually packed in substantial carton or other container, properly marked or labeled to be readily identifiable with Hardware Schedule.

Storage: General Contractor shall furnish secure storage area for delivery by Hardware Supplier of finish hardware and storage of same. General Contractor shall be responsible for shortages due to theft and pilferage.

General Contractor shall provide in storage area adequate counters, shelves, and bins for assembly and grouping of hardware for distribution and installation.

PART 2: PRODUCTS

TYPES, SIZES AND DESCRIPTIONS:

Hardware shall be of types and sizes listed in this Section, applied with fastenings of proper size, quantity and finish.

Templates: Hardware for application on metal shall be made to standard templates. Furnish physical samples or templates, as required to Manufacturer of metal doors and frames for proper manufacturer and application.

Reinforcement: Reinforcing for hardware shall be furnished and installed by Door and Frame Manufacturer.

Modifications to hardware required by reasons of construction characteristics shall be such as to provide same operative or functional features.

Provide hardware for fire rated openings in compliance with UL, UL 10C-1998, UBC 7-2-1997, NFPA-80 and CFR Part 36 (ADA) guidelines. Provide only hardware, which has been tested and listed by UL for types and sizes of doors scheduled. All hardware shall conform to ADA requirements. These requirements take precedence over any other requirements or specifications of this section.

Category "A" Positive Pressure Installations:

Hardware located above 40" AFF to be listed and labeled in accordance with UBC 7-2-1997 and UL 10C-1998 for use in positive pressure fire rated wood doors.

In order to meet smoke requirements, a smoke seal, listed and labeled for UBC 7-2-1997 Parts 1 and 2 positive pressure installations, must be mounted around the perimeter of the doorframe.

Flat bar type astragals only will be allowed on pairs of doors with fire ratings up to 60 minutes with concealed intumescent inside the door structure.

Provide strikes with extended lips as necessary.

Provide wrought strike boxes, with dust box insert.

Provide doors to loading platforms, boiler and mechanical rooms, stages or platforms, utility stairs, and electrical closets with knurling on inside of lever.

Locksets: Provide HD Grade 1 mortise locksets as scheduled, with standard LW lever trim and wrought rose. All cylinder key cores shall be interchangeable type, removable cores. Provide original manufacturer's pins and brass key blanks.

Provide CODE required tactile warning surfaces (knurling) for all door operating hardware for doors leading to mechanical, boiler, electrical, or chemical storage areas.

KEYING REQUIREMENTS

Provide removable construction cores, Owner will change when building is accepted.

Keying: All locks and cylinders to be construction master keyed, and grand master keyed to the Owner's Corbin-Russwin "59C1 keyway" mastered key system. Provide 4 59C1 keys per cylinder, stamped with keying symbol. All cylinders standard 6-pin type.

Keys and cores shall be shipped direct from manufacturer to Owner, Beaufort County Schools, Facility Services, Attention: LOCKSMITH.

Hardware supplier shall meet with the General Contractor, Architect's representative and Owner's Hardware Representative/Locksmith to receive keying instructions before preparing keying schedule for approval.

Representative from the key company is required to meet with Owner's representative prior to turning cylinders, and to turn all cylinders.

The general contractor shall install the key cabinet. The hardware supplier shall set up the key cabinet with the Owner's representative and user present, prior to the completion of construction. The Owner shall be notified 3 weeks in advance.

One Manufacturer: Following items within each classification shall be furnished totally by one manufacturer.

Hinges	Locksets
Exit devices	Closers

Door Stops: All doors shall be provided with wall stops or overhead stops, to suit condition. For example, doors opening onto millwork or open space shall receive overhead stops. Solid wood blocking to be installed at all gypsum wallboard wall stop locations. Provide floor stops at fire doors with magnetic hold open devices.

Fire rated openings: All fire rated openings, except classrooms, shall receive closers and ball bearing hinges, whether scheduled or not.

Astragals:

Non-fire rated door pairs with flush bolts shall receive steel astragal on exterior side edge of the active leaf.

Pairs of smoke or fire doors shall receive split astragals, gaskets and smoke seals and necessary hardware to meet fire rating designated.

Pairs of double egress fire doors shall receive steel astragals on exterior side edge of each leaf, with gaskets and smoke seals and necessary hardware to meet fire rating designated.

Keyed Removable Mullions: All interior and exterior mullions to be removable with keyed operation, with cylinder and cores installed by the general contractor and turned by the hardware supplier.

Hinges: Unless otherwise noted, 3 butt hinges shall be provided each interior door to 36" width and 86" height. 3 heavy-duty butt hinges shall be provided for interior doors exceeding 36" width or 86" height.

Exterior hinges shall be heavy-duty ball bearing butt hinges.

Materials and Finishes: (All products except closers, thresholds, weatherstripping to have brass or bronze base metal unless otherwise noted).

	<u>Materials</u>	<u>Finishes</u>
Locksets, Escutcheons		626
Continuous Hinges, Exterior Doors	6063 T6 Aluminum	Clear Anodized
Butt Hinges, Interior Doors	Steel	US 26 D
Pivots	Satin Chrome Plate	US 26 D
Exit Devices	Satin Chrome Plate	US 26 D
Cylindrical Lock Trim	Satin Chrome Plate	US 26 D
Dead Lock Trim	Satin Chrome Plate	US 26 D
O.H. Holders & Stops	Satin Chrome Plate	US 26 D
Door Stop and Holders	Satin Chrome Plate	US 26 D
Box Strikes	Wrought	Prime
Thresholds	Aluminum	Aluminum
Thresholders	Steel	Galvanized Steel
Weatherstrip	Aluminum	Aluminum
Flatgoods	Stainless	US 32 D

Fasteners:

Use concealed fasteners whenever possible.

Hardware to be installed on metal work shall be furnished with machine screws.

For exposed fasteners on interior in bronze or brass, use matching color and material for fasteners. For all other exposed fasteners on interior, use stainless steel except where noted specifically otherwise.

Furnish stainless steel screws for all exterior work.

Install fixed locking screw in strike plate for exterior locksets after final adjustments made during 6-Month Service and Adjustment Inspection.

HARDWARE ITEMS:

All Products shall be by one of the following manufacturers - no exceptions:

- a. Butt Hinges: All Doors; 4 ½" (BB) ball bearing, Hager, Stanley, McKinney
- b. Surface Closers: LCN 4040XP, Closer can mount hinge side, top jamb, or parallel arm (with PA bracket) on either right or left swinging doors. Provide metal covers with set screw anchors, in matching finish. Provide ADA rated features.
- c. Locksets: Corbin / Russwin ML2000 Series Mortise Locksets, heavy-duty Grade 1, with LW lever and standard wrought rose.
- d. Electrified Mortise Lockset: ML 20900 ECL Series-LWM x 626, complete assembly with power supply, and electric thru wire hinge EPT.
- e. Cylinders: Full Size Interchangeable Core, all interior and exterior cylinders to be provided with interchangeable cores, with construction cores prior to Owner occupation.
- f. Exit Devices: Von Duprin 99 Series, each with a cylinder for trims and a cylinder for dogging.
- g. Electronic Access Control Exit Devices (Furnished and installed by the General Contractor's Division 8 Subcontractor): Von Duprin QEL, with EPT for hinge edge power transfer.

- h. Wherever doors are equipped with exit devices, view windows shall have concealed / flush glass beads.
- i. Removable Mullions: Von Duprin, Yale, keyed type with key cylinder/core.
- j. Overhead Holders/Stops: Glynn-Johnson, ABH Manufacturing.
- k. Thresholds: National Guard, Pemko, Hager.
- l. Push/Pulls: Rockwood Manufacturing, Ives, Hager.
- m. Stops: Glynn-Johnson, Rockwood Manufacturing, Ives, Hager.
- n. Flush Bolts: Glynn-Johnson, Rockwood Manufacturing, Ives, Hager.
- o. Silencers: Glynn-Johnson, Rockwood Manufacturing, Ives.
- p. Kick Plates: Rockwood Manufacturing, Ives, Hager.
- q. Automatic Flush Bolts: Glynn-Johnson, Rockwood Manufacturing.
- r. Astragals: National Guard, Pemko, Hager, Reese.
- s. Weather strip & Rain Drips: National Guard, Pemko, Hager, Reese.
- t. Door Bottoms: National Guard, Pemko, Hager.
- u. Smoke Perimeter Door Frame Gaskets: Pemko, Hager, Reese
- v. Smoke Door Bottom Sweep: Pemko, Hager, Reese
- w. Magnetic Door Holders: LCN SEM 7800 Series, with adjustable extension length.

Other items shall be as scheduled.

Provide the following hardware material as scheduled in the door schedule:

Hinges with closer	BB 1279 4 ½ x 4 ½
St/Stl hinges with closer	BB 1191 4 ½ x 4 ½
HD hinges with closer	BB 1168 4 ½ x 4 ½
St/Stl HD hinges w closer	BB 1199 4 ½ x 4 ½
Privacy set	(F19) ML2030
Staff Toilet Privacy set	(F19) ML2030 Occupied Indicator
Passage set	(F01) ML2010
Classroom security lockset	(F32) ML2052 Intruder Latchbolt Lock
Entrance lockset	(F04) ML2051
Office lockset	ML2053
Storeroom lockset	(F07) ML2057
Electrified Mortise Lockset	ML 20900 ECL Series-LWM x 626
Push/Pull latchset	HL6
Exit device (interior)	99 996L all interior locations (F as req'd)
Exit device (interior)	99 996L locations scheduled (F as req'd).
Exit device (exterior)	99 NL x DT with pull or fixed lever exterior doors, with CD cylinder dogging.
Exit Device at EAC	QEL with EPT where EAC (Electronic Access Control) is scheduled.
Mullion	4954 (9954 as req'd), keyed type.

Electric Strike:	Von Duprin 6000 Series
Cylinder	Standard 6-pin
Closer	4040XP-3077 regular arm, metal cover
Closer with backstop	4040XP-3077CNS Cush-n-Stop Arm (CUSH), metal cover
Kick plate	1935 8 x 2 LDW
Wall stop	232 W
Floor stop	241 F
Overhead stop	9-331
Flush bolts	282 D
Threshold	Pemko 2005AV
Upper rain drip	Reese R201C
Lower rain drip	Pemko 345, for exterior in swinging doors
Lower rain drip/sweep	Pemko 345_V, for exterior out swinging doors
Frame Smoke gasketing	Pemko 332CR
Door Bottom Smoke Sweep	Pemko 307AV
Perimeter gasketing	Pemko 296_R
HD Interlock gasketing	Pemko 336
Astragal with Gasketing	Pemko 375 Series
Split Astragal Gasketing	Pemko 310 Retainer Bar / 311 CIN Inserts
Meeting Stile Gasketing	Pemko 369_V
Push plate	70C 4 x 16
Pull handle	107 x 70C 4 x 16
Key cabinet	Lund Equipment, Telkee, provide cabinet with 350 key capacity, expandable to 700 capacity; Model 1205 or accepted equivalent.

General and Special Hardware Notes:

1. All doors to receive hinges as specified
2. All doors to receive wall or overhead stops to suit condition of use. Doors with magnetic hold opens to receive floor stops.
3. Provide closers with backstops for exterior doors and to suit condition of use, all closers to be through-bolted.
4. All steel frames to be provided with silencers.
5. Exterior and IDF Room doors to be provided with weather-stripping and thresholds.
6. All exit devices to be provided with cylinder locks, and CD cylinder dogging.
7. At pairs of doors, pull side, provide pull or lever both sides, unless otherwise noted.
8. Aluminum doors – See specifications for hardware not indicated above.
9. Provide cylinders for keyed mullions supplied by aluminum door supplier.
10. Provide solid wood blocking for door stops and hold open devices
11. Exit devices at exterior doors to NL with pull or lever, unless otherwise indicated.
12. Exit devices at interior doors to be classroom function with latching lever.
13. Provide 4" wide steel jambs for doors abutting steel columns and special conditions as noted.

CONTROLLED ACCESS SYSTEM / HARDWARE DEVICES

1. WHERE INDICATED ON DRAWINGS, PROVIDE ACCESS CONTROL SYSTEM DEVICES AND COMPONENTS, DOOR HARDWARE AND ACCESSORIES, FULLY COMPATIBLE WITH AN S2 SECURITY ACCESS CONTROL SYSTEM AND SOFTWARE PROGRAM, INCLUDING BUT NOT LIMITED TO THE FOLLOWING COMPONENTS. ALL HARDWARE / EQUIPMENT SPECS SHALL COMPLY WITH PERQUIMANS COUNTY SCHOOL STANDARDS.
 - a. CARD / PROXIMITY READER UNIT: HID ICLASS CARD READER, MODEL S2-900PTNNEK00460-S2SEC, MINI-MULLION VERSION WHERE REQUIRED. PROVIDED BY THE DIVISION 17 ACCESS CONTROL CONTRACTOR.

- b. ACCESS CONTROL SYSTEM FIELD PANEL: S2 NETWORK NODE, S2-NN-E2R-WM, HOUSING UP TO SEVEN (7) S2 APPLICATION BLADES, SUPPORTING UP TO 14 DOORS, WITH NETWORK DROP - PROVIDED BY THE DIVISION 17 ACCESS CONTROL CONTRACTOR. ELECTRICAL CONTRACTOR TO PROVIDE ELECTRICAL POWER.
 - c. ACCESS CONTROL BASE STATION: COMPUTER SOFTWARE PROGRAM, INSTALLED ON OWNER'S PC, FOR SOFTWARE CONTROL OF CONNECTED DOORS - PROVIDED BY THE DIVISION 17 ACCESS CONTROL CONTRACTOR.
 - d. DOOR CONTACTS FOR NEW DOOR/FRAMES: RECESSED DOOR SWITCH SETS, GRI 180 SERIES, 195-12WG, BY GEORGE RISK INDUSTRIES. DOUBLE POLE, DOUBLE THROW, WIDE GAP. PROVIDED BY THE DIVISION 17 ACCESS CONTROL CONTRACTOR. ELECTRICAL CONTRACTOR TO PROVIDE RACEWAY TO DOOR FRAME.
 - e. POWER SUPPLIES, FOR ALL POWERED DOOR LOCKING HARDWARE / EXIT DEVICES. PROVIDED AND INSTALLED BY DIVISION 8 DOOR HARDWARE SUPPLIER.
 - f. VON DUPRIN QUIET ELECTRIC LATCH RETRACTION – QEL EXIT DEVICE 98/99 SERIES. PROVIDED AND INSTALLED BY DIVISION 8 DOOR HARDWARE SUPPLIER.
 - g. EPT ELECTRIC POWER TRANSFER (articulating frame to door raceway): VON DUPRIN MODELS EPT 2, EPT 10, EPT10C (As Application Requires), FOR USE WITH VON DUPRIN QEL EXIT DEVICES. PROVIDED AND INSTALLED BY DIVISION 8 DOOR HARDWARE SUPPLIER.
 - h. ELECTRIFIED MORTISE LOCKSET: ML 20900 ECL SERIES-LWM X 626, COMPLETE ASSEMBLY WITH POWER SUPPLY, AND ELECTRIC THRU WIRE HINGE EPT.
 - i. ELECTRIC HINGES: HAGER ETW ELECTRIC THROUGH WIRE HINGE, WITH FOUR CONTINUOUS ELECTRIC CONDUCTORS, FULL MORTISE BALL BEARING, WITH MOLEX TYPE CONNECTORS, BY HAGER. PROVIDED AND INSTALLED BY DIVISION 8 DOOR HARDWARE SUPPLIER.
- 2 INTERCOM / VIDEO CAMERA UNIT (DOOR CALL STATION UNIT):
- WHERE INDICATED, PROVIDE A COMPLETE VIDEO INTERCOM BUZZ-IN ACCESS SYSTEM ASSEMBLY, AIPHONE IX SERIES OR EQUIVALENT, INCLUDING BUT NOT LIMITED TO THE FOLLOWING COMPONENTS.
- 1)DOOR STATION: INTERCOM BUZZER UNIT WITH VIDEO CAMERA, WITH ALUMINUM OR STAINLESS STEEL COVER PLATE. AIPHONE IX SERIES OR EQUIVALENT. WEATHER RESISTANT COVER PLATE FOR EXTERIOR STATION.
 - 2)MASTER STATION: MASTER VIDEO STATION WITH PICTURE MEMORY, DOOR STRIKE RELEASE TOGGLE OR SWITCH, TABLE TOP MOUNTED AT RECEPTION DESK. AIPHONE IX SERIES OR EQUIVALENT.
 - 3)POWER SUPPLY: PS-1820UL POWER SUPPLY
- 3. WORK OF ALL SPECIFICATION DIVISIONS SHALL BE COORDINATED BY THE GENERAL CONTRACTOR, INCLUDING WORK BY DIVISION 16 AND DIVISION 17 SUBCONTRACTORS, AND SHALL BE COMPLETE IN ALL RESPECTS.
 - 4. CONTROLLED ACCESS SYSTEM DEVICES SHALL BE COMPLETE, WITH ALL NECESSARY COMPONENTS; TO INCLUDE BUT NOT LIMITED TO POWER SUPPLY DEVICES, CABLES AND

CABLING, ELECTRICAL POWER CIRCUITS IN REQUIRED VOLTAGES, RACEWAYS, BOXES, TRANSFORMERS, CONTACTORS, RELAYS, SOLENOIDS, ETC.

PART 3: EXECUTION

GENERAL:

Consult project drawings and details and otherwise become familiarized with work so that all items furnished will conform to openings to which applied.

Coordinate hardware with other allied trades such as carpentry, millwork, metal frames, etc.

Prepare and submit to Architect for approval as promptly as possible three (3) copies of completed detailed schedule.

Immediately after award of hardware contract, request approved shop drawings from such trades with which hardware must be coordinated.

After checking approved shop drawings, supply promptly such template information, template drawings, approved hardware schedule, etc., as may be required to facilitate progress on job.

APPLICATION:

Apply hardware in accordance with approved Shop Drawings, with fastenings of proper size, quantity, and finish, and in accordance with Manufacturer's instructions coordinate.

Operation: All items of hardware shall fit and operate properly.

HARDWARE LOCATIONS:

Door Pulls: 42" from finished floor to center of grip.

Push-Pull Bar: 42" from finished floor to center of bar of center between bars and combination.

Top Hinge: To frame Manufacturer's standard, but not greater than 10" from head of frame to centerline of hinge.

Bottom Hinge: To frame Manufacturer's standard but not greater than 12-1/2" from finished floor to centerline of hinge.

Intermediate Hinges: Equally spaced between top and bottom hinge. Doors exceeding 36" width shall be provided with 2 pair hinges.

Locks and Latches: 38" from finished floor to center of knob.

Deadlocks (with separate latch-set and/or pull): 60" from finished floor to centerline of strike.

Locate pivots in accordance with Pivot Manufacturer's requirements.

FINAL INSPECTION: After installation of all finish hardware is completed, and before building is accepted, General Contractor shall have capable representative of hardware manufacturers, minimum of an AHC, visit building to inspect and approve installation; to make all necessary adjustments; and to carefully instruct Owner in proper use, servicing, adjusting and maintaining of hardware.

SIX MONTH SERVICE AND REPORT: Six months after acceptance of each area of the project, readjust each item of hardware and restore to proper function. Install fixed locking screw in strike plate for exterior locksets after final adjustments made during 6-Month Service and Adjustment Inspection. Consult with Owner regarding recommended additions or modifications to maintenance procedures. Clean and lubricate as required. Replace items, which have deteriorated or failed due to faulty design, materials, or installation. Provide Architect with written report upon completion of above.

END OF SECTION

RELATED DOCUMENTS:

The general provisions of the Contract, including General and Supplementary Conditions, and General Requirements, apply to the work specified in this Section.

PART 1: GENERAL

SUMMARY:

Provide glass, glazing, metal panels, and special fire glass as indicated below, complete.

Work Included This Section:

Glass and Glazing For:

- Aluminum Entrances
- Steel and Wood Doors
- View Windows and Panels
- Exterior Windows
- Metal Window Insulated Panels
- Special fire glass

INDUSTRY STANDARDS:

For listing of names of industry standard agencies mentioned by abbreviation in this Section refer to Section 01068.

QUALITY ASSURANCE:

Provide safety glass (tempered, laminated) complying with requirements of ANSI Z97.1 - American National Standard for Glazing Materials Used in Buildings -- Safety Performance Specifications and Method of Test.

Label each piece of glass designating type and thickness of glass. Do not remove label prior to installation.

Permanently identify each unit of tempered glass. Etch or ceramic fire identification on glass; identification shall be visible when unit is glazed.

Warranty: Provide manufacturer's standard 10 year warranty, including replacement of sealed glass units exhibiting seal failure or leakage, interpane dusting or misting.

Manufacturers:

Standard: For purposes of designating type and quality for work under this Section, Drawings and Specifications are based on products manufactured or furnished by following manufacturers:

- American St. Gobain Corporation

- Libby-Owens-Ford Glass Company
- Mississippi Glass Company
- Pittsburg Plate Glass Company
- Technical Glass Products
- Nippon Electric Glass Co., Ltd.
- Pilkington
- Vitro

SUBMITTALS:

Glass and Glazing: Submit samples of each type of glass, metal insulated panel, glazing compound, sealant and tapes for Architect's approval.

Product Data: Submit copy of manufacturer's specifications and installation instructions for each type of glass and glazing material. Include test data or certification substantiating that glass complies with specified requirements and manufacturer's warranties.

Submit manufacturer's standard 10 year warranty for insulated glass units.

MANUFACTURER'S LABELS:

Labels showing Glass Manufacturer's identity, type of glass, thickness and quality will be required on each piece of glass. Labels must remain on glass until it has been set and inspected.

Containers: All glazing compounds shall arrive at project site in unopened, labeled containers.

PRODUCT HANDLING:

Sizes of glass indicated on Drawings are approximately only. Determine actual size required by measuring frames to receive glass at project site, or from guaranteed dimensions provided by Frame Supplier.

Cutting: All glass shall be cleancut. Nipping to remove flares or to reduce oversized dimensions of any type of glass will not be permitted.

Deliver glass to site in suitable containers that will protect glass from weather and from breakage. Store material in safe place to minimize breakage, but deliver sufficient glass to allow for normal breakage.

DESIGN AND PERFORMANCE REQUIREMENTS:

Watertight and airtight installation of each piece of glass is required. Each installation must withstand normal temperature changes, wind loading, impact loading (for operating doors) without failure of any kind including loss or breakage of glass, failure of sealants or gaskets to remain watertight and airtight, deterioration of glazing materials, and other defects in work.

PART 2: PRODUCTS

GLASS:

Exterior Glazing:

SuperGrey Tinted Solar Control Low-E Insulating Glass: 1" thick panels; 1/4" thick "deep cool-grey" low-reflective body-tinted float glass to exterior, 1/4" clear Low-E solar control glass to interior; Low-E shall be on the 3rd surface, with 1/2" space between glass panes by dessicant filled spacer and sealant device.

Pilkington SuperGrey / Energy Advantage:

Properties: Pilkington SuperGrey / Energy Advantage Low-E Glass

Glazing:	Exterior
Type:	Insulated
Total Thickness:	1" (24 mm)
Space Filler:	Dehydrated Air Space
Outboard Lite:	1/4" SuperGrey Tinted Float Glass
Inboard Lite:	1/4" Energy Advantage Low-E Glass, #3 Surface
Low-E Surface:	3 rd Surface
Heat Strengthened:	Safety as required – see elevations
Tempered:	Safety as required – see elevations
Visible Light Transmittance (%):	LT 7%
Visible Lite Exterior Reflectance (%):	LRo 4%
Visible Lite Interior Reflectance (%):	LRi 13%
Total Solar Energy Direct Transmittance (%):	ET 5%
Total Solar Energy Reflectance (%):	ER 4%
U-V Transmittance (%):	UV 1%
Solar Heat Gain:	SHGC 0.15
Shading Coefficient:	TSC 0.18

Acid-Etched Obscure Glass: For all window glass at toilet rooms, shower rooms, and locker rooms, provide 1" Solargray with Solarban Low-E on 2nd surface, with acid-etched obscure glass clear (no color) lite on 3rd surface.

Spandrel Glass: Spandrel glass at locations indicated shall be obscure ceramic coating on #4 surface.

Provide impact resistant glass throughout where required under Chapter 24, Section 2406, North Carolina State Building Code, 2006 Edition, Category I and II, CPSC 16CFR1201.

Interior Impact Resistant Glass: 1/4" laminated impact resistant, 2 layers clear tempered glass with sandwiched interlayer of .30 Cat II polyvinyl butyral (PVB).

Fire Rated Glass: Where indicated, provide fire-rated impact resistant glass, doors and frames for protected openings as indicated on Drawings, equivalent to "Pyrostop" glass and "FIREFRAMES", "Heat Barrier Series", manufactured by Technical Glass Products. Conform to UL 10 C, UBC 7-2, and UBC 7-4, UL File No. R-19207, design U533. Frame tests to pass ASTM E-119, NFPA 251, UL 263, UL 9, UL 10C, UBC 7-2 and UBC 7-4.

Exterior Aluminum Entrance Doors: 1/4" "Pilkington SuperGrey" Low-E tempered safety glass, impact resistant as required.

Interior Doors: 1/4" clear tempered safety glass, provide impact resistant where indicated, and as required per applicable code standards.

Interior Windows: 1/4" clear tempered safety glass, provide impact resistant where indicated, and as required per applicable code standards.

SETTING BLOCKS AND SPACER SHIMS:

Fabricate blocks and shims from neoprene. Shape to required size and thickness. Material used for blocks and spacers must be compatible with type of compounds and sealants used and shall not cause staining or discoloration of sealant or frame.

Shore A durometer hardness of setting block and shim material shall be 70 to 90 points for setting blocks and 50 points for spacer shims, or as recommended by compound or sealant manufacturer.

METAL WINDOW PANELS

Metal window panels consist of metal skins laminated to stabilizer substrates with an insulating core material. Panels are designed to be glazed into a window system or curtain wall system.

Laminated metal faced insulated panels equivalent to "MapeShape" panel as manufactured by Mapes Industries, Inc., 1" total thickness, with formed edges for glazing into a 1" glazing pocket.

Exterior & Interior Finish:: Kynar factory paint finish on 0.032" smooth finished aluminum skin, color as selected by Architect from factory colors, minimum selection of 20.
Provide 25-year finish warranty.

Insulation Core: 2.0 lb. density polystyrene
R-Value: R-6.0 per inch

GLAZING MATERIALS:

Sealant and Compound shall be Vulkem 116 by Master Mechanics Company, Maccolastic Acrylic Compound by Macco Division, Glidden Company, Betaseal 850 by Essex Chemical Company or approved equal.

Glazing Tape shall be butyl rubber sealant type partly vulcanized, self-adhesive, non-staining, elastomeric butyl rubber tape, complying with AAMA 800.

Bestaseal 650 Tape by Essex Chemical Company
Duraribbon 1070 by PPG Industries
176 Strucsureglaze by Protective Treatments Company

Compatibility: Where combination of sealing materials is required for glazing in same frame, manufacturer shall certify that all glazing materials furnished are compatible with each other and compatible with material used for setting blocks and spacer shims.

PART 3: EXECUTION

CONDITION OF SURFACES:

Preparation: Check all frames prior to glazing. Openings shall be square, plumb, and with uniform face and edge clearances. Maintain 1/8" minimum bed clearance between glass and frame on both sides.

Clean all surfaces to be glazed with xylol, a 50-50 mixture of acetone and xylol, or other solvents recommended by compound or sealant Manufacturer. Any defects affecting satisfactory installation of glass shall be corrected before starting of glazing.

Temperature: Do not apply any compound or sealant at temperatures lower than 40 degrees F.

INSTALLATION:

Workmanship: Apply glazing compound uniformly with accurately formed corners and bevels. Remove excess compound from glass and frame. Use only recommended thinners, cleaners and solvents. Do not cut or dilute glazing compound without approval from Architect. Make good contact with glass and frame when glazing and facing off.

Cleaning: Compound shall be removed from glass before it hardens. Remove any excess sealants from glass and adjoining surfaces during working time of material, within two to three hours.

Blocks and Spacers: Where setting blocks and spacer shims are required to be set into glazing compound or sealant, they may be butted with compound or sealant, placed in position, and allowed to set firmly prior to installation of glass.

Miscellaneous Interior Glazing: Unless otherwise indicated, all interior glass shall be channel glazed with glazing compound. Apply as follows:

Apply ample back compound to rabbet so that it will ooze out when glass is pressed into position and completely cover glass in rabbet. Press glass into position.

Secure glass in place by application of stop beads. Bed stop beads against glass and bottom of rabbet with compound, leaving proper thickness between glass and stop beads. Secure stop beads in place with suitable fastenings. Strip surplus compound from both sides of glass and tool at slight angle to provide clean sight lines.

Glazing Aluminum Entrances and Window Wall System:

Glass shall be set in accordance with aluminum entrances and window walls Manufacturer's shop drawings and instructions.

Install moldings level, plumb and square. Moldings at corners shall be accurately cut, neatly fitted, and joined as recommended by Storefront manufacturer.

REPLACEMENTS AND CLEANING:

Condition: At completion of work, all glass shall be free from cracks, sealant smears and other defects.

Protection/Replacement: Protect glass surfaces and edges during the construction period. Keep glass free from contamination by materials capable of staining glass. Any glass that is defective before

acceptance, or within one year warranty period, as result of manufacturing, transporting, or performance of Contractor, shall be removed and replaced with new glass without cost to Owner.

END OF SECTION

RELATED DOCUMENTS:

Drawings and general provisions of Contract, including General and Supplementary Conditions and Division-1 Specification sections, apply to work of this section.

PART 1 - GENERAL

SUMMARY / SCOPE

Security Glazing film applied to designated glazing assemblies. This specification is for an optically clear glass shatter resistant and abrasion resistant window film which, when applied to the interior window surface, will help hold broken glass together and reduce the ultra-violet light that normally would enter through the window. This is an easily applied, tear-resistant safety and security window film for providing an increased measure of protection in a broad range of uses including basic glass fragment retention, spontaneous glass breakage, seismic preparedness, safety glazing, protection from windborne debris, bomb blast mitigation, and deterring Smash and Grab or Break and Entry events. Certain applications may require the film be used in conjunction with a film attachment system. The film shall be 14 mil 3M Safety S140 Safety and Security Window Film.

CODES AND REFERENCES:

The publications listed below form a part of this specification to the extent referenced. The publications are referred to in the text by the basic designation only.

The 1985 American Society for Heating, Refrigeration, and Air Conditioning Engineers (ASHRAE) Handbook of Fundamentals. The American National Standards Institute (ANSI).

ANSI Z97.1 Specification for Safety Glazing Material used in Buildings

The American Society for Testing and Materials (ASTM):

1. ASTM E-308 Standard Recommended Practice for Spectrophotometry and Description of Color in CIE 1931 System
2. ASTM E-903 Standard Methods of Test for Solar Absorbance, Reflectance and Transmittance of Materials Using Integrating Spheres
3. ASTM D-882 Standard Test Method for Tensile Properties of Thin Plastic Sheeting
4. ASTM D-1044 Standard Method of Test for Resistance of Transparent Plastics to Surface Abrasion (Taber Abrader Test)
5. ASTM D-2582 Standard Test Method for Puncture-Propagation Tear Resistance of Plastic Film and Thin Sheeting
6. ASTM D-4830 Standard Test Methods for Characterizing Thermoplastic Fabrics Used in Roofing and Waterproofing.
7. ASTM G-90 Standard Practice for Performing Accelerated Outdoor Weatherizing for Non-metallic Materials Using Concentrated Natural Sunlight
8. ASTM G 26 Standard Practice for Performing Accelerated Outdoor Weatherizing for Non-metallic Materials Using Concentrated Natural Sunlight
9. ASTM E-84 Standard Method of Test for Surface Burning Characteristics of Building Materials
10. ASTM D-1004 Standard Method of Test for Resistance of Transparent Plastics to Tearing (Graves Tear Test)
11. ASTM E-1886 Standard Test Method for Performance of Exterior Windows, Curtain Walls, Doors, and Impact Protective Systems Impacted by Missile(s) and Exposed to Cyclic Pressure Differentials
12. ASTM E-1996 Standard Specification for Performance of Exterior Windows, Curtain Walls, Doors and Impact Protective Systems Impacted by Windborne Debris in Hurricanes
13. ASTM F-1642 Standard Method of Test for Glazing and Glazing Systems Subject to Airblast Loadings, as adapted by the U.S. Government GSA Test Standard Protocols
14. ASTM F-2912 Standard Specification for Glazing and Glazing Systems Subjected to Airblast Loadings

The Consumer Products Safety Commission (CPSC) 16 CFR, Part 1201, Safety Standard for Architectural

Glazing Material

GSA-TS01-2003 General Services Administration Standard Test for Glazing and Glazing Systems Subject to Airblast Loadings

QUALITY ASSURANCE

- A. Manufacturer Qualifications: Glazing film manufacturer specializing in manufacture of security glazing films with minimum 10 years successful experience.

SUBMITTALS

- A. Submit under provisions of Division 1.
- B. Test Reports: Detailed reports of full-scale chamber tests to specified criteria, using assemblies identical to those required for this project.
- C. Product Data: Manufacturer's data sheets on each product to be used, including:
 - 1. Record of product certification for safety requirements.
 - 2. Preparation instructions and recommendations.
 - 3. Storage and handling requirements and recommendations.
 - 4. Installation methods.
- D. Samples: For each film product to be used, minimum size 4 inches by 6 inches, representing actual product, color, and patterns.
- E. Specimen warranty.

DELIVERY, STORAGE, AND HANDLING

- A. Store products in manufactures unopened packaging until ready for installation.
- B. Store and dispose of solvent-based materials, and materials used with solvent—based materials, in accordance with requirements of authorities having jurisdiction.

FIELD CONDITIONS

- A. Maintain environmental conditions (temperature, humidity, and ventilation) within limits recommended by manufacturer for optimum results. Do not install products under environmental conditions outside manufacturer's absolute limits.

WARRANTY

- A. Provide 15-Year manufacturer's replacement warranty to cover film against delaminating, peeling, cracking, discoloration, and deterioration.
- B. Provide 5-Year manufacturer's replacement warranty to cover glass failure due to thermal shock fracture of the glass unit.

PART 2 - PRODUCTS

MANUFACTURER'S

- A. The film shall be 3M Safety S140 Safety and Security Window Film, as manufactured by 3M Commercial Solutions Division.
- B. Substitutions: Not Permitted.

MATERIALS

A. Security Glazing Film:

1. Transparent polyester film for permanent bonding to glass. The film material shall consist of an optically clear polyester film, consisting of co-extruded micro-layers, with a durable acrylic abrasion resistant coating over one surface, and a UV stabilized pressure sensitive adhesive on the other. The film color is clear and will not contain dyed polyester. The film shall have a nominal thickness of 14 mils (0.014 inches). There shall be no evidence of coating voids.

B. Film Properties (nominal):

- a) Tensile Strength (ASTM D882): 25,000 psi
- b) Break Strength (ASTM D882): 25,000 psi
- c) Percent Elongation at Break (ASTM D882): >125%
- d) Percent Elongation at Yield (ASTM D882): greater than 100%

C. Solar Performance Properties: film applied to ¼" thick clear glass

- a. Visible Light Transmission (ASTM E 903): 85%
- b. Visible Reflection: not more than 10%
- c. Ultraviolet Transmission: less than 1% (300 – 380 nm)
- d. Solar Heat Gain Coefficient: 0.78

D. Flammability: The Manufacturer shall provide independent test data showing that the window film shall meet the requirements of a Class A Interior Finish for Building Materials for both Flame Spread Index and Smoked Development Values per ASTM E-84.

- a. Flame Spread Index (FDI): 5
- b. Smoke Developed Index (SDI): 25

E. Abrasion Resistance: The Manufacturer shall provide independent test data showing that the film shall have a surface coating that is resistant to abrasion such that, less than 5% increase of transmitted light haze will result in accordance with ASTM D-1044 using 50 cycles, 500 grams weight, and the CS10F Calibrase Wheel.

F. Adhesion to Glass: The Manufacturer shall provide independent test data showing that the film shall have a 90-degree peel strength (adhesion to glass) according to ASTM D-1044 of at least 6 lbs/in.

G. Adhesive System: The film shall be supplied with a high mass pressure sensitive weatherable acrylate adhesive applied uniformly over the surface opposite the abrasion resistant coated surface. The adhesive shall be essentially optically flat and shall meet the following criteria:

- a. Viewing the film from a distance of ten feet at angles up to 45 degrees from either side of the glass, the film itself shall not appear distorted.
- b. It shall not be necessary to seal around the edges of the applied film system with a lacquer or other substance in order to prevent moisture or free water from penetrating under the film system.

H. Impact Resistance for Safety Glazing: The Manufacturer shall provide independent test data showing that the film, when applied to either side of the window glass, shall meet the 400 ft-lb impact requirements of 16 CFR 1201 (Category 2) and ANSI Z97.1 (Class A, Unlimited). Testing shall be done with film applied both on 1/8" and ¼" annealed glass.

I. Provide supplemental anchoring system as required to meet forced entry resistance requirements. Anchoring System: DOW 995 or GE SCS2000 SilPruf Structural Sealant with high impact styrene trim.

J. Impact Protection: per ASTM E1886 / E1996

PART 3 - EXECUTION

EXAMINATION

- A. Field -Applied Film: Verify that existing conditions are adequate for proper application and performance of film.
- B. Examine glass and frames, insure that existing conditions are adequate for proper application and Performance of film.
- C. Verify glass is not cracked, chipped, broken, or damaged.
- D. Verify that frames are securely anchored and free of defects.

PREPARATION

- A. Clean glass of dust, dirt, paint, oil, grease, mildew, mold, and other contaminants that would inhibit adhesion.
- B. Immediately prior to applying film, thoroughly wash glass with neutral cleaning solution.
- C. Protect adjacent surfaces.
- D. Do not begin installation until substrates have been properly prepared.

INSTALLATION

- A. Install in accordance with manufacturer's instructions, without air bubbles, wrinkles, streaks, bands, thin spots, pinholes, or gaps, as required to achieve specified performance.
- B. Accurately cut film with straight edges to required sizes allowing 1/16-inch to 1/8-inch gap at perimeter of glazed panel unless otherwise required by anchorage method.
- C. Seams. Seam film only as required to accommodate material sizes; seam without overlaps.
- D. Clean glass prior to film installation with neutral cleaning solution.
- E. Peel back release liner and apply film to glass. Using squeegees, push out solution between film and glass.
- F. Once film is installed, anchor the edges of the film by applying approved structural sealant and high impact styrene to the edges of the frames and film.
- G. Clean glass and excess structural sealants from finished surfaces
- H. Remove any labels or protective covers.

FILM VERIFICATION

- A. Awarded contractor will be required to verify that film installed meets the requirements highlighted in this bid. By submitting a bid, you as the contractor understand that three pieces of glass, chosen at random will be removed and film applied will be measured to verify that film installed meets specifications as requested. Film may need to be removed as part of the verification process.

PROTECTION

- A. Protect installed products until completion of project.
- B. Touch-up, repair or replace damaged products before Substantial Completion.

END OF SECTION

RELATED DOCUMENTS:

Drawings and general provisions of Contract, including General and Supplementary Conditions and Division-1 Specification sections, apply to work of this section.

PART 1 - GENERAL

1.01 SUMMARY

- A. Provide all labor, materials, accessories, and equipment required to furnish and install stationary louvers as shown on the accompanying plans and specified in this document.
- B. Coordinate stationary louver work of this section with HVAC Ductwork.
- C. Provide gable end construction / waterproof dormers work shown on the drawings, as specified herein, and as needed for a complete assembly and proper installation.
- D. Coordinate dormer and louver work of this section with:
 - 1. Section 05400 Cold Formed Metal Stud Framing
 - 2. Section 07200 Building Insulation
 - 3. Section 07610 Metal Roofing
 - 4. Section 09250 Gypsum Drywall Systems
 - 5. Division 15 HVAC Ductwork
 - 6. Division 5 Structural Roof Framing.

1.02 SUBMITTALS

- A. Submit shop drawings designed in accordance with local building code requirements. Upon approval, general contractor shall send to field or job-site superintendent copy of final approved shop drawing.
- B. Submit color samples of exterior coverings.
- C. Submit certificates of insurance.
- D. Submit close-out documents, warranties, and manuals.

1.03 QUALITY ASSURANCE

- A. Use adequate number of skilled workmen who are thoroughly trained and experienced in the necessary crafts, and who are completely familiar with the specified requirements and the methods needed for proper performance of the work of this Section.
- B. Use materials which shall be free from defects impairing strength, durability, and appearance; shall be of best commercial quality for purpose required; and shall comply with approved drawings.
- C. Use manufacturer who has had ten (10) years of experience in the manufacture of specified product.

1.04 WARRANTY

- A. Warrant the product for one year after date of completed installation of product by others

PART 2 - PRODUCTS

2.01 STATIONARY LOUVERS:

- A. Louvers shall be Models EME420DD Wind-Driven Rain Stationary Louver – Horizontal Blade; with Model ELT – Triangular Shaped Louvers, as manufactured by Ruskin.
- B. Fabricate custom shaped louvers as indicated on Drawings.
- C. Louvers shall have the following features:
 - a. The unit shall have a rain proof exterior.
 - b. Sightproof double drainable blades shall be constructed of not lighter than .063" 6063T5 extruded aluminum @ 3" o.c. Minimizes penetration of wind-driven rain.
 - c.
 - d. Frame shall be 4" constructed of not lighter than .081" wall thickness extruded aluminum.
 - e. Furnish extended sill and insect screen.
 - f. Finish shall be 70% PVFD Kynar 500 with 20 year warranty or approved equal – provide manufacturer's standard colors and/or custom color(s) selected by Architect
- D. Equivalent products by Air Balance, Vent Products, Cesco or Reliable are acceptable.

2.02 ACCESSORIES

- A. Bird Screening – 5/8" x .040" expanded flattened aluminum bird screen in removable frame. Screen adds approximately 1/2" to louver depth.
- B. Utilize extruded aluminum louvers for mechanical intake and exhaust as indicated on Drawings.
- C. Form cornices, mouldings, and ornaments in accordance with approved drawings.
- D. Provide flashing flange around perimeter of dormer/gable end opening. Use .032" aluminum cladding, 3003-H14 alloy, with available stock finishes.
- E. Provide extended sill.
- F. Provide blank off panels.

FABRICATION

- A. Fabricate trims and flashings in accordance with SMACNA requirements.
- B. Form all exterior cladding with good and acceptable sheet metal practices, and lock form all seams inasmuch as possible.
- C. Conceal all exterior fasteners to maximum possibility.
- D. Use cadmium plated bolts, nuts, and washers for anchoring, unless anchoring materials are provided and installed by others.

FINISHES

- A. Provide with 70% PVDF Kynar 500 finishes.
- B. Submit (3) color samples for approval by the Architect.

CAULKING

- A. Clean and dry all surfaces to be caulked.
- B. Apply with caulking gun, using nozzle of proper size to fit the joint width.
- C. Use polyurethane caulk as specified in 07610 Metal Roofing and 7900 Joint Sealers, or approved equal.

PART 3 - EXECUTION

3.01 PROJECT SITE CONDITIONS

- A. Verify with owner or general contractor that site conditions are suitable and accessible for delivery.
- B. Confirm with owner or general contractor that all preparatory work is in place in accordance with approved shop drawings before delivery.
- C. Field measure all rough openings prior to fabrication.

3.02 INSTALLATION

- A. Install all louvers in accordance with SMACNA requirements.
- B. Caulk perimeters with necessary accessories as required for watertight installations.
- C. Coordinate with other trades as required to assure proper and adequate installation of backup weather wall.
- D. Clean all soiled and dirty areas and touch up any scratches or abrasions to finish before lifting into position.
- E. Install work with skilled workmen who are familiar with such work in accordance with approved shop drawings.
- F. Provide crane to manufacturer for unloading for as long as required.

3.03 CLEAN-UP

- A. Clean up all debris caused by work of this section.
- B. Remove all caulk and sealant remnants from adjacent surfaces.
- C. Keep the premises clean and neat at all times.

END OF SECTION

RELATED DOCUMENTS:

Drawings and general provisions of Contract, including General and Supplementary Conditions and Division-1 Specification sections, apply to work of this section.

PART 1: GENERAL

DESCRIPTION OF WORK:

Under this Section, provide gypsum board for wall assemblies (non-fire rated and fire-rated), partitions, ceilings, ceiling access doors, fireproofing for beams and columns as indicated on drawings and as specified herein.

Note all gypsum drywall, except as noted on drawings, shall be provided with a LEVEL 4" gypsum wallboard finish.

INDUSTRY STANDARDS:

For listing of names of industry standard agencies mentioned by abbreviation in this Section refer to Section 01068.

QUALITY ASSURANCE:

Manufacturers:

Standard: For purposes of designating type and quality for work under this Section, Drawings and Specifications are based on products manufactured or furnished by United States Gypsum Company.

Acceptable Manufacturers: Products of following manufacturers which meet all requirements of these specifications will be acceptable:

- U.S. Gypsum
- CertainTeed Corporation
- Georgia-Pacific
- National Gypsum Company

Source: Products for use on this Project shall be of one Manufacturer for same function, unless noted specifically otherwise herein.

SUBMITTALS:

Manufacturer's Data: Submit (in duplicate) Manufacturer's printed catalog cuts, installation instructions, and finishing instructions.

Test Reports: Submit (in duplicate) reports from Underwriter's Laboratories, Inc. or other acceptable testing agencies, on fire tests of designs referred to in Contract Documents.

Mock-up Sample: Fabricate a field mock-up of a gypsum wallboard assembly, across a drywall panel joint, with a crack control joint installed, with the specified drywall finishing primer and paint finish coats, for review and approval by Architect. Approved mock-up will stand on site for reference as the project standard for all gypsum wall board walls.

PRODUCT HANDLING:

Delivery: Deliver materials in original packages, containers or bundles bearing brand name and name of manufacturer or supplier for whom product is manufactured.

Storage: Gypsum board and insulation material delivered prior to use shall be stored within completely weather tight structure, off ground, and completely enclosed within weather tight covering. Stack all board materials on 2"x 4" risers, spaced 16" o.c. Weather tight covering shall also extend completely under stacked material to prevent seepage of moisture if over uncovered ground or damp slab.

Handling: Exercise care, during handling and storage, to avoid undue sagging or damage to edges, ends, and surfaces.

ENVIRONMENTAL CONDITIONS:

Building: Application of gypsum board shall commence only after structure is completely weather -tight.

Temperature: In cold weather and during period of gypsum board application and joint finishing maintain temperatures in building uniformly within range of 55 degrees to 70 degrees F. Provide adequate ventilation to eliminate excessive moisture in building during same period.

PART 2: PRODUCTS

MATERIALS:

Gypsum Board shall be furnished in 48" widths and in lengths of at least 2" greater than height from floor to finished ceiling to permit vertical installation of all boards. Contractor shall have option to furnish boards for vertical installation full height to structure above where required in one sheet, 48" wide.

Types: Gypsum Board shall conform to following:

1. Gypsum Board shall be fire-resistive type throughout of various thicknesses indicated, equivalent to Sheetrock Brand Firecode C. Provide impact resistant gypsum wallboard at locations indicated on Drawings.
2. All 5/8" thick gypsum board shall be taper-edged, fire-resistive, conforming to ASTM C 1396.
3. Mold and Mildew Resistant Gypsum Board shall be "Sheetrock Mold Tough Gypsum Wallboard" 5/8" tapered-edge with treated manila paper finish and "Sheetrock Mold Tough Fire-code C Wallboard, 5/8" tapered-edge with treated manila paper finish for 1 hour rated partitions. Use 5/8" mold and mildew resistant gypsum board for ceilings of janitor closets, shower rooms, tub rooms.
4. Tile Backer Board: Use 5/8" tile backer board for backup of all areas scheduled to receive thin set ceramic tile. Moisture resistance silicone core reinforced with inorganic glass fiber matt. "DenShield Tile Guard" by Georgia-Pacific, or equal products by approved manufacturers.
5. Exterior Wall Sheathing Board shall be 5/8" thick fire retarding fiberglass reinforced gypsum board, with sealed and taped joints: "Dens-Glass Gold" by Georgia-Pacific, or equal products by approved manufacturers.
6. Gypsum Soffit board shall be 5/8" thick, fire coded, exterior gypsum soffit board by Bestwall, U. S. Gypsum, or equal products by approved manufacturers.

7. Sheetrock Brand First Coat drywall finishing primer.

FASTENERS:

Screws for attachment of board to metal studs and metal ceiling and wall furring shall be 7/8" or 1" US Drywall Screw, Type S. All screws shall have bugle head.

METAL AND PLASTIC CORNER BEADS AND TRIM:

Interior Work:

Metal: Fabricate metal corner beads from galvanized steel, not lighter than 0.02" nominal thickness, in following shapes and sizes.

1. Corner Beads for all 90 degree external corners shall be equivalent to USG No. 100-Perf-A-Bead.
2. Metal Trim shall be equivalent to USG 200 Series Perf-A-Trim, sized for wallboard thickness.

REINFORCING TAPE AND JOINT TREATMENT (INTERIOR)

Tape shall be equivalent to "Perf-A-Tape".

Compound for embedding and fill coat application shall be equivalent to "Perf-A-Tape Joint Compound".

Compound for finishing shall be equivalent to "Perf-A-Tape Topping Compound".

ADHESIVE AND CAULKING:

Laminating Adhesive: Laminating adhesive for face layer application in double-layer systems shall be equivalent to "Perf-A-Tape Joint Compound, embedding type".

Caulking Compound: Acoustical type sealant, furnished by Gypsum Board products manufacturer.

CRACK CONTROL JOINTS:

Crack control joints shall be provided in pre-approved locations as directed by the Drawings and the Architect, at each jamb of windows exceeding 10' in width, in walls at 40' intervals, and in ceilings at 30' intervals. Provide manufacturer standard metal exp/control joint material.

PART 3: EXECUTION

CONDITION OF SURFACES:

Inspection: Examine surfaces to receive gypsum board for defects, which might impair quality of finished installation. Do not start work until such defects have been corrected.

Framing Spacing: Framing members to which gypsum board will be fastened shall be straight and true, and spaced as indicated on Drawings, not to exceed 16" o.c. for walls and ceilings. Framing and bridging members shall be adequate to carry design or code loading. Bridging members shall be spaced 48" o.c.

Supplemental Framing: Provide back blocking and framing as necessary for support of fixtures and all mounted equipment.

Coordination: Conduit, piping, retainers for corner guards and other items to be concealed by or penetrating, wallboard shall be installed and tested before applying wallboard.

INSTALLATION OF GYPSUM BOARD:

Cutting and Fitting:

Cut gypsum board by scoring and breaking, or by sawing. Work from face side.

Cut edges and ends of gypsum board shall be smoothed where necessary, in order to obtain neat jointing when board is erected.

Cut-outs for pipes, fixtures or other small openings shall be scored on face and back in outline before removal, or shall be cut out with saw or other suitable tools.

Where gypsum board meets projecting surfaces, scribe and cut neatly, fitting closely for caulked joint.

Application of Gypsum Board:

Apply continuous bead of Acoustical Sealant on floor at line of contact of board.

Walls: Apply gypsum board vertically, pressing into sealant, with boards in moderate contact, but not forced into place. At interval and external corners conceal cut edges of boards by overlapping covered edges of abutting boards. Arrange joints on opposite sides of partitions so as to occur on different framing members. Place long dimensions of panels parallel to furring or framing members. Panels shall be of length required to reach from 2" above ceiling line to floor line in one continuous length. Make joints over framing or furring members.

Ceilings: Apply board to ceilings with long dimension of board at right angles to furring members. At perimeters of all ceilings, edge joint shall be laid on metal trim strip against continuous bead of caulking, applied in advance of board application.

Gypsum Board End Joint at masonry walls shall be laid on metal trim strip against continuous bead of caulking, applied in advance of board application.

Corner Beads and Metal Trim: Internal corners do not require corner beads, but shall be reinforced with tape. External corners shall have corner bead fitted neatly over corner, and secured with same type fasteners used for applying wallboard.

ATTACHMENT:

Method: Space fasteners not less than 3/8" nor more than 1/2" from edge and ends of board. While fasteners are being driven, hold board in firm contact with under laying support. Application of fasteners shall proceed from central portion of board to ends and edges. If paper surface is broken by fastener in attachment, drive another fastener approximately 2" from faulty fastener.

Drive screws to provide screw head penetration just below gypsum board surface.

Spread adhesive over laminating surface of face or base layer gypsum board. Extend adhesive up to ends and edges of all board.

Spacing of Fasteners shall be as follows:

Screw Method: Space screws at maximum of 12" o.c. for ceilings and 16" o.c. for walls.

Corner Beads and Trim shall have fasteners spaced 6" o.c. driven through gypsum board into framing members.

JOINT FINISHING AND FASTENER CONCEALMENT:

Provide "LEVEL 4" gypsum wallboard finish at all areas, unless indicated otherwise.

Provide total coverage coat of Sheetrock Brand First Coat Primer or equivalent prior to paint coats. Reference 09900.

Method: Mix and use joint compound and topping compound in accordance with manufacturer's recommendations printed on bag. Apply by machine or hand tool. Allow minimum drying time of 24 hours between adhesive coats. Sand all coats as necessary after each application. Clean excess compound from surface of gypsum board as compound is applied.

Reinforcement: Reinforce wall and ceiling angles and inside vertical corner angles with tape folded to conform to adjoining surfaces, and to form straight, true angle. All gypsum board joints except joints at metal trim shall be tapered.

Embedment Coat: Apply thin, uniform layer of joint compound (embedding type) approximately 3" wide over joint to be reinforced. Center tape over joint and seat into compound; leaving sufficient compound under tape to provide proper bond. Apply skim coat of compound immediately after embedding tape.

Fill Coat: After drying, cover embedding compound with fill coat of compound. Spread evenly over and slightly beyond tapered edge area of board. Feather at edges.

Topping: Cover fill coat with topping compound. Spread evenly over and slightly beyond edge of proceeding coat. Feather with smooth, uniform finish.

Fastener Concealment: Treat dimples at fasteners (and holes where temporary fasteners are removed) with three coats of joint compound applied as each coat is applied to joints.

Conceal flanges of all corner beads and trim members by minimum of two coats of compound applied strictly in accordance with Manufacturer's directions.

Caulking:

Joints at Penetrations: Where pipes, conduits, ducts, electrical devices, etc., penetrate gypsum board, seal joint around perimeter with caulking compound.

Joints between ceilings and walls shall be sealed continuously with acoustical sealant, as specified above.

DRYWALL CEILING ACCESS DOORS: Provide 24" x 24" x 16 gauge minimum primed steel ceiling access doors each space with drywall ceiling, hinged and with key lock. Provide UL Listed fire-rated doors all locations where a rating is required. Provide USG No. 200-B metal trim on all edges of gypsum board. Finish as specified in 09900 Paint.

END OF SECTION

RELATED DOCUMENTS:

Drawings and general provisions of Contract, including General and Supplementary Conditions and Division-1 Specification sections, apply to work of this section.

PART 1: GENERAL

DESCRIPTION OF WORK:

Work under this section includes providing drywall metal stud partition system, metal framed drywall ceiling furring system, metal stud wall furring system, and drywall ceiling suspension system, for installation of gypsum board.

RELATED WORK:

Section 05400 Cold-Formed Metal Stud Framing
Section 09250 Gypsum Drywall Systems

INDUSTRY STANDARDS:

For listing of names of industry standard agencies mentioned by abbreviation in this section refer to Section 01068.

QUALITY ASSURANCE:

Manufacturers:

Standard: For purposes of designating type and quality for work under this Section, Drawings and Specifications are based on products manufactured or furnished by United States Gypsum Company.

Acceptable Manufacturers: Products of following manufacturers, which meet all requirements of these specifications, will also be acceptable:

- ClarkDietrich Building Systems
- MarinoWARE
- Telling Industries
- USG Interiors

Source: Products for use on this Project shall be of one manufacturer for same function, unless noted specifically otherwise herein.

SUBMITTALS:

Shop Drawings: Show complete details of construction, including gauges of metal, anchors, fastenings, special fittings, and accessories. Show ceiling framing and furring, special wall framing, and framed openings.

Manufacturer's Data: Submit (in duplicate) Manufacturer's printed data on materials and installation for work specified herein. Include reports on fire tests and physical data.

PRODUCT HANDLING:

Delivery: Deliver materials to Project site in the original packages, containers or bundles, bearing brand name, and name of manufacturer or supplier for whom product is manufactured.

Storage: Store materials to prevent damage from exposure to elements.

PART 2: PRODUCTS

METAL STUD PARTITION SYSTEM: Metal stud partition system shall be USG Metal Stud System, or approved equal, designed for screw attachment of gypsum board, furnished with required fasteners and accessories for complete system.

Steel Studs shall be C-shaped, formed from not less than 20-gauge galvanized steel sheets, USG width as shown on drawings. Stud webs shall have punched holes throughout for utility lines or wiring.

Metal Floor and Ceiling Runners shall be channel-shaped, formed from not less than 25-gauge galvanized steel sheets, with minimum 1-1/4" flanges and web-sized to nest with steel studs specified.

Screws for attachment of studs to runner and other framing fastening where specified shall be 3/8" USG Drywall Screw, Type S, pinhead.

WALL FURRING SYSTEM: Wall furring system shall be USG Drywall Wall Furring System, designed for screw attachment of gypsum board furnished with required fasteners and accessories for complete system.

Furring Channels shall be hat-shaped USG Drywall Furring Channels, or equal, roll-formed from not less than 25-gauge galvanized steel, 2-3/4" wide by 7/8" deep with 1/2" minimum wing flanges and 1-3/8" minimum crown width for gypsum board attachment.

Fasteners for attachment of furring channels (or wall furring brackets) shall be as recommended by furring manufacturer.

Brackets for furred-out utility space shall be USG adjustable wall furring brackets, formed from not less than 20-gauge galvanized steel. Horizontal leg shall have serrated edges for wire-tie of carrying channels.

Carrying Channels shall not be less than 16-gauge cold-rolled channels, 3/4" web width and 1/2" flange depth, spaced 48" on center maximum. Finish with black asphaltum.

Tie Wire shall be not less than 16-gauge soft annealed carbon steel wire.

FRAMED DRYWALL CEILING SYSTEM: Framed ceiling system for framed gypsum board ceilings shall be USG Drywall Ceiling System, designed for screw attachment of gypsum board, furnished with required fasteners and accessories for complete system.

Furring Channels for gypsum board applied to ceiling framing shall be hat-shaped USG Drywall Furring Channels, roll-formed from not less than 25-gauge galvanized steel, 2-3/4" wide by 7/8" deep with 1/2" minimum wing flanges and 1-3/8" minimum crown width for gypsum board attachment. Provide cross-carrying Cold Rolled C-channels as specified at 48" centers.

For framed dropped ceilings, soffits, and where indicated at expansion joints, C-shape stud framing is acceptable, not less than 25-gauge galvanized steel, in sizes indicated on Drawings.

DRYWALL CEILING SUSPENSION SYSTEM: For drywall ceiling suspension systems, provide USG Drywall suspension System, Flat Ceilings and Wall-To-Wall, as manufactured by USG Interiors, minimum G-40 hot-dipped galvanized steel members. Provide G-90 galvanized members for exterior applications. Provide UL rated fire-resistive assemblies where required. All main tees, cross tees, and main tee-hanger wire connections shall meet ASTM E580 requirements for tension and compressive strength, as tested by ASTM C1925. Member spacing shall be determined by the manufacturer using the applicable membrane loads.

System components shall include straight main tees, cross tees, spanning tees, moldings, clips, any and all necessary accessories for a complete assembly.

Provide 30-year Warranty, covering no-visible sag, and mold/mildew protection.

Install in accordance with ASTM C636, ASTM E580, ASTM C754, and written manufacturer's requirements.

END OF SECTION

RELATED DOCUMENTS:

Drawings and general provisions of Contract, including General and Supplementary Conditions and Division-1 Specification sections, apply to work of this section.

PART 1: GENERAL

SCOPE:

Work included in this section:

- Surface Preparation Materials
- Setting Materials
- Sloped Setting Beds
- Grout
- Flexible Sealants
- Glazed Porcelain Floor Tile
- Glazed Porcelain Wall Tile
- Tile Accessories

INDUSTRY STANDARDS:

Tile Council of North America (TCNA) Handbook for Ceramic Tile Installation – Current Edition.

Current edition of American National Standard Specifications for the installation of ceramic tile; A108 / A118 / A136.1, A137.

Current editions of ASTM C 150, ASTM C 206, ASTM C 207, ASTM C 144, ASTM C627.

Current edition of International Standards Organization (ISO) 13007; Standards for Ceramic Tiles, Grouts and Adhesives.

EJ171 Movement Joint Guidelines for Ceramic, Glass, and Stone - Tile Council of North America (TCNA) Handbook for Ceramic, Glass, and Stone Tile Installation – Current Edition.

For listing of names of industry standard agencies mentioned by abbreviation in this Section refer to Section 01068.

QUALIFICATIONS:

Manufacturers:

Standard: For purposes of designating type and quality for work under this Section, Drawings and Specifications are based on products manufactured by the Dal-Tile Company, MAPEI Corporation, and Schluter Systems.

Other acceptable Manufacturers whose products are acceptable for this Project are:

- American Olean
- Crossville

Source: Products for use on this Project shall be of one Manufacturer for same function.

SUBMITTALS:

Samples: Submit one sample each of following materials to Architect for approval.

Panels of tile approximately 6 inches square for each pattern and type of floor or wall tile.

Samples of each tile trim shape, and each metal trim shape, and each accessory specified.

Manufacturer's Data: Submit (in duplicate) Manufacturer's printed instructions on following:

- Surface preparation materials
- Mortar for floors
- Mortar for walls
- Grout for floors
- Epoxy Grout for floors
- Grout for walls
- Epoxy Grout for walls
- Flexible Sealants
- Finishing, edge protection and transition profiles for floors
- Finishing and edge protection profiles for walls

Certificates: Furnish Master Grade Certificate bearing Certification Mark of Tile Council of America, signed by Manufacturer and Tile Subcontractor, stating type and quantity of material furnished for Project.

PRODUCT HANDLING:

Delivery: Deliver materials to Project site in Manufacturer's original packages, and with seals unbroken. Only tile which bears Certification Mark of Tile Council of America on each carton will be permitted. Maintain package seals until time for installation.

Storage: Store cementitious material in dry building, on platforms off floor, and in area free from wetting. Store tile and accessory material in clean, dry, covered area to prevent wetting or staining.

ENVIRONMENTAL CONDITIONS:

Temperature: Do not apply mortar to surfaces containing frost. Minimum temperature for installation of tile shall be 40 degrees F, and maintained during installation, and until fully cured in accordance with Manufacturer's written installation instructions.

Ventilation: Control movement of air to prevent too rapid evaporation of moisture for mortar in place.

PROTECTION:

Traffic Restrictions: Spaces in which tile is being set shall be closed to traffic and other work during installation and for at least 72 hours after completion of tile work.

PART 2: PRODUCTS

MATERIALS:

Provide materials in compliance with current editions and up-to-date industry product standards cited.

Portland Cement: ASTM C 150 Type 1, white.

Hydrated Lime: ASTM C 206 Type S, or ASTM C 207 Type S

Sand: ASTM C 144 - washed clean and graded. Use fine sand passing 1/16-inch mesh screen when mixed for grouting; use white sand for white cement.

Pigment - Grout shall be colored; colors to be selected by Architect.

Water: Clean and potable.

Mortar Bed: ANSI A108.1B; equivalent to 4 to 1 Mud Bed mixed with Planicrete AC by MAPEI.

Accelerated Mortar Bed: ANSI A108.1A; equivalent to Topcem Premix by MAPEI Corporation.

Concrete Patch: equivalent to Mapecem Quickpatch concrete patch by MAPEI Corporation.

Crack Isolation Sheet Membrane: equivalent to Mapeguard CI, pee-and-stick crack isolation sheet membrane for tile installations, by MAPEI Corporation, compliant with current edition of ASTM C627 Extra heavy service rating, and current edition of ANSI A118.12. Provide the applicable MAPEI primer.

Crack Isolation Membrane: equivalent to Mapelastic CI, pre-mixed liquid rubber crack isolation membrane for tile installations, by MAPEI Corporation, compliant with current edition of ASTM C627 Extra heavy service rating, and current edition of ANSI A118.12.

Improved Modified Dry-Set Cement Mortar: ISO 13007; C2ES2P2 and ANSI A118.4HE / A118.11, ANSI A118.15HE; equivalent to Kerabond/Keralastic System by MAPEI Corporation.

Polymer-Modified Large and Heavy Tile Mortar: ISO 13007 C2TE and ANSI A118.4HTE, A118.11; equivalent to Keraflex Plus by MAPEI Corporation.

GLASS-MESH MORTAR UNITS: Dens Shield Tile Backer by Georgia Pacific.

Unsanded Grout: ISO 13007: CG2WA, ANSI A118.6 premium pre-blended polymer modified unsanded grout, equivalent to Keracolor U Unsanded Grout. For 1/16" to 1/8" joints in floor and wall surfaces.

Sanded Grout: ISO 13007: CG2WA, ANSI A118.6 premium pre-blended polymer modified sanded grout, equivalent to Keracolor S Sanded Grout. For 1/8" to 3/16" joints in floor and wall surfaces.

High-Performance Cement Grout: ANSI A118.7 and ISO 13007 CGWAF, equivalent to MAPEI, Ultracolor Plus FA. For grout joints from 1/16 inch to 3/4 inch.

Epoxy Grout: ISO 13007; R2RG and A118.3; equivalent to Kerapoxy CQ by MAPEI Corporation, provide epoxy grout at all shower floors and walls. For grout joints from 1/8 inch to 3/16 inch.

Commercial Industrial-Grade Water-Cleanable Epoxy Grout: ANSI A118.3 and ISO 13007 RG, equivalent to MAPEI Kerapoxy IEG CQ. Provide enzymatic cleaner resistant epoxy grout at all food service/kitchen floor and wall tile areas. For grout joints from 1/8 inch to 3/16 inch.

Flexible Sealant: 100%-Silicone Sealant: Rated for Heavy-traffic expansion and movement joints, horizontal and vertical complying with ASTM standards; Meets ASTM C920, Type S, Grade NS, Use T1, T2, NT, I, M, G, A, and O, conforming to C794 adhesion properties; equivalent to MAPEI Mapesil T Plus.

ACCESSORIES

Aluminum Wall Tile Termination Edge Protection: Schluter – RONDEC, with termination end caps, for use with wall tile, for terminating wall tile. Featuring an AE extruded satin anodized aluminum finish, radiused exposed profile and an 1/8" thick integral perforated embedment anchoring leg.

Aluminum Wall Base Edge Protection: Schluter – SCHIENE Model AE-100, for use with tile wall base. L-shaped aluminum profile x 1/8" thick exposed visible leg and integrated perforated anchoring leg, and grout joint spacer, with satin anodized finish. Provide with or without wall tile directly above wall tile base.

Aluminum Corner Protection: Schluter – QUADDEC Model Q 100 AE, at all outside corners for use with wall tile and tile wall base. Aluminum profile with square shaped exposed surface and integrated perforated anchoring leg, and integrated grout joint spacer, with satin anodized finish. Provide caps and termination accessories.

Aluminum Floor Transition: Schluter – RENO-U Model, for floor tile transitions to carpet, VCT, linoleum tile (LT) or terrazzo floor finishes. Aluminum profile with sloped exposed surface, ADA Compliant 1/2" Max. Transition Height x 5/32" tall leading abutment edge, and integrated perforated anchoring leg, and integrated grout joint spacer, with AEU satin anodized finish.

TILE:

All tile shall conform to current editions of ANSI A108.3, .4, .5, and .6; ANSI A137.1.

Floor Tile:

Floor tile shall be 6" x 6" nominal x 5/16" thick glazed porcelain with cushion edge, Daltile "Volume 1.0 with StepWise Technology slip resistance". Provide for all floor tile areas, with exceptions of shower areas. Provide with 3/16" grout joints. Equivalent products from American Olean or Crossville are acceptable. Architect shall choose from ten (10) available standard colors.

Shower Stalls floor tile shall be Dal-tile 2"x2" Mosaics, mesh mounted, Grade 1 mosaic tiles.

Wall base shall be 12" x 12" floor tiles split in half to 6" high x 12" wide nominal units, installed with use of Schluter SCHIENE aluminum trim cap and QUADDEC aluminum outside corners, complete assemblies. All wall base vertical and horizontal joints shall align.

Wall Tile: (Field & Accent)

Wall tile shall be nominal 12" x 24" nominal x 3/8" thick glazed porcelain tile, Daltile "Volume 1.0". Vertical joints shall align with floor and wall base joints. Provide polymer modified large and heavy tile mortar and 3/16" grout joints.

Terminate top horizontal edges of wall tile with a course of 3" x 12" bullnosed wall cap.

Provide all materials as necessary for providing a complete tile installation. All trim shapes shall be same size as field tile, and vertical and horizontal joints shall align.

Wall accent tile shall be nominal 12" x 24" nominal x 3/8" thick glazed porcelain tile, selected from Daltile "Volume 1.0 - Accent Colors". Vertical joints shall align with floor and wall base joints. Accent tile, calculated as 25% of total wall tile area, shall be selected from manufacturer's six (5) standard colors, in a

pattern as directed by Architect for each space. Provide polymer modified large and heavy tile mortar and 3/16" grout joints. Provide full range of trim shapes or profiles necessary for accent complete assemblies.

MIXES:

Proportion and mix materials, and apply in accordance with manufacturer's most current written instructions and applicable ANSI standards.

PART 3: EXECUTION:

CONDITIONS OF SURFACES:

Substrates:

Examine substrate surfaces to receive tile for compliance with requirements for conditions affecting performance of the work. Refer to ANSI A108.01, ANSI A108.02 and if applicable ANSI A108.19.

Perform a substrate inspection for identification and location of all cracks within the substrate surfaces, and where needed, apply/install crack isolation products specified or equivalents, with required primers, in accordance with the written manufacturer's instructions, and current editions of ANSI 118.12 and ASTM C627, ANSI A108.01, ANSI A108.02 and if applicable ANSI A108.19.

Do not proceed with tile work until surfaces and conditions comply with requirements indicated in referenced tile installation standard and manufacturer's printed instructions.

When underlayment, patching, leveling and rendered materials are needed, they must be from the supplier of the setting materials, for improved warranty and single-sourced responsibility.

When using tiles with all edges shorter than 15 inches in length, the maximum allowable variation in the substrate -1/4 inch in 10 feet from the required plane, with no more than 1/16 inch variation in 12 inches when measured from the high points in the surface.

When using large-format tiles with at least one edge of 15 inches in length, the maximum allowable variation in the substrate is 1/8 inch in 10 feet from the required plane, and 1/16 inch variation in 24 inches when measured from the high points in the surface.

Surfaces to receive tile shall be dry, clean, free of oily or waxy films, firm, level, and plumb. Do not start work until completion of work of other trades, which are in or behind tile work.

INSTALLATION:

General Requirements for Installation of Tile:

Installation shall conform to all recommendations contained in the current edition of Tile Council of North America Handbook for Ceramic Tile Installation:

STUD WALLS:	W244-23	Thin set over backer board.
	W245-23	Thin set over glass mat backer board
MASONRY WALLS:	W202I-23	Thin set mortar over masonry/concrete.
KITCHEN MASONRY WALLS:	W202I-23	Thin set mortar over masonry/concrete, epoxy grout
SHOWER WALLS	B415-23	Thin set over cement backer board, epoxy grout
SHOWER FLOOR:	B-415-23	Thin set over mortar setting bed floor, epoxy grout.
ELEVATED SLAB PORCELAIN TILE FLOORS	F-113A-23	Thin set mortar to concrete bond coat.
SOG PORCELAIN TILE FLOORS:	F-112-23	Thin set over bonded mortar bed.

PORCELAIN TILE KITCHEN FLOORS: F-114-23 Thin set over unbonded mortar bed, epoxy grout.

Fitting: Cut and drill tile for proper fitting around work projecting through wall allowing for escutcheons and collars to overlap cuts. Rub exposed, cut edges.

Wall tile and wall base terminations will be provided with specified Schluter trim accessories. Cut edge or square edge terminations will not be accepted.

Pattern: Lay out tile lengthwise so that no tile of less than half size occurs. For heights stated in feet and inches, maintain full courses to nearest attainable height without cutting tile.

Base: Determine level of finish floor so that bottom lip of base will not be below finish floor level. Floor level at wall shall be at constant elevation around room, and will drain water away.

Lines: Install tile to true, straight lines, with uniform joints, both vertically and horizontally.

Joints: Except where otherwise shown or specified, joints in wall tile shall be vertical and horizontal, and joints in floor tile be perpendicular and parallel to walls. Maximum grout joint width of 3/16".

Floor Tile Installations:

All SLAB-ON-GRADE (SOG) floor tile installations will be on depressed slabs with recessed mortar setting beds, sloped to drains. Install mortar setting bed to recessed floor substrate or fill. Screed and tamp firmly. Minimum thickness of setting bed shall be minimum 1/2" at drain fixture. Level setting bed to tolerances required for finished floors.

Slope setting beds to floor drains, continuous from room perimeters to the drain fixture grate, for continual positive drainage at all areas. Shall be flood tested for positive drainage, witnessed by the Architect and Owner.

All elevated SLAB-ON-DECK (SOD) floor tile installations will be thin-set on elevated slab substrate, without setting beds, with cast-in-place concrete slab continuously sloped to floor drains. At all areas of thin set floor tile installations without setting beds, slope concrete floor slabs from room perimeters to floor drain grates for continual positive drainage. Shall be flood tested for positive drainage, witnessed by the Architect and Owner.

Provide polymer-modified, large and heavy tile mortar for bonding all tile with a 15 inch or longer edge. All wall tile units shall be back buttered.

Install expansion joints and control joints in accordance with TCNA method EJ171.

Grouting:

Grout joints in accordance with manufacturer's instructions and ANSI A108.06 and/or ANSI A108.10.

Remove standing water, dust, and foreign substances from joints to be grouted.

Clean and dry tile surfaces. After grouting, remove all grout residue promptly.

Install expansion and control joints in accordance with TCNA method EJ171.

Cleaning:

Clean tile thoroughly prior to sealing, using methods approved by the tile manufacturer. Use of acid or acid cleaners to clean tile is strictly prohibited.

Curing:

Floors: Protect from all traffic for at least 72 hours after installation.

Do not step on and protect the floor for at least 24 hours.

If traffic is unavoidable after initial 24-hour protection, use plywood stepping boards protection.

Protect from heavy traffic for at least 7 days after installation.

When fast-setting materials are used to allow faster occupancy, comply with manufacturer's recommendations.

Walls: Protect from impacts, vibration, and heavy hammering on adjacent and opposite walls for 14 days after installation, unless manufacturer's instructions allow a shorter period.

Protect from stain-causing food products and chemicals for at least 14 days.

Protect from freezing and total water immersion for at least 21 days after installation.

NOTE: When dealing with cement-based products, temperature and humidity during and after installation of tile affect final cure time. Low temperatures: 60 degrees F and under, and high humidity: 70% and above, will delay final cure time.

Extra Stock: Furnish Owner with extra stock in unopened boxes, 5% of each color used.

END OF SECTION

RELATED DOCUMENTS:

Drawings and general provisions of Contract, including General and Supplementary Conditions and Division-1 Specification sections, apply to work of this section.

PART 1 – GENERAL

1.01 RELATED DOCUMENTS

- A. Drawings and general provisions of the Contract, including General and Supplementary Conditions and Division 1 Specification Sections, apply to this Section.

1.02 SUMMARY

- A. Scope of work:
 - 1. Providing a 3/8" thick epoxy terrazzo finish, a minimum of 800 grit polish. Colors and patterns to be selected by Architect.
- B. Section Includes:
 - 1. Thin-set Epoxy Terrazzo Flooring including preparation of substrates.
 - 2. Related accessories.
- C. Related Sections:
 - 1. Division 3, Concrete, (for depressed floor slab requirements).
 - 2. Division 4, Masonry.
 - 3. Division 5, Metals.
 - 4. Division 7, Thermal and Moisture Protection
 - 5. Division 9, Finishes
 - 6. Division 15A, Furnishing and setting floor drains.
 - 7. Section 01040, Temporary heat, water and electricity.

1.03 SUBMITTALS

- A. Manufacturer's product data for each type of terrazzo and accessories.
 - 1. Compliance physical properties, including vapor barrier primer.
 - 2. Performance properties.
 - 3. Specified tests.
 - 4. Material Safety Data Sheet.
 - 5. Manufacturer's standard warranty.
- B. Shop Drawings: Include terrazzo installation requirements. Include plans, elevations, sections, component details and attachments to other work. Show layout of the following:
 - 1. Divider strips.
 - 2. Control- and expansion-joint strips.
 - 3. Base and border strips.
 - 4. Abrasive strips.
 - 5. Terrazzo patterns.
- C. Samples for Initial Selection: NTMA and Manufacturer's color plates showing the full range of colors and patterns available for each terrazzo type indicated, using premium marble terrazzo chips from the Carolina Colors Collection.
- D. Samples for Verification: Match Architect's samples for each type, material, color and pattern of terrazzo and accessory required showing the full range of color, texture and pattern variations expected. Label each terrazzo sample to identify manufacturer's matrix color and aggregate types, sizes and proportions. Prepare samples of same thickness and from same material to be used for the Work in size indicated below:
 - a. Epoxy Terrazzo: minimum 6" x 6" (152.4 mm x 152.4 mm) sample of each color and type of terrazzo.
 - b. Accessories: 6" length (152.4 mm) of each kind of divider strip, stop strip and control joint strip required.
- E. Manufacturer Experience:
 - a. Submit proof of Associate membership in NTMA.

- b. Furnish a list of at least five (5) epoxy terrazzo projects using material being submitted for this project installed during the last five (5) years of the same scope, complexity and at least 50 percent of the square footage.
- c. Epoxy manufacturer shall have 10 years of experience in sales and manufacturing epoxy for installation with NTMA members.
- F. Qualification Data: For qualified Installer.
 - a. Submit proof of Contractor membership in NTMA.
 - b. Furnish a list of at least five (5) epoxy terrazzo projects using material being submitted for this project installed during the last five (5) years of the same scope, complexity and at least 50 percent of the square footage.
- G. Material Test Reports: For moisture and/or relative humidity of substrate.
- H. Maintenance Data: Submit 5 copies of NTMA maintenance recommendations and 5 copies of manufacturer's instructions.

1.04 QUALITY ASSURANCE

- A. Installer Qualifications: A qualified installer who is acceptable to Architect and epoxy terrazzo manufacturer to install manufacturer's products.
 - 1. Engage a terrazzo contractor with at least five (5) years of satisfactory experience in installation of epoxy terrazzo. Terrazzo contractor shall demonstrate experience during last five (5) years of at least (5) projects of comparable scope and complexity of at least 50 percent of the total square footage of this project.
 - 2. Engage an installer who is a contractor member of NTMA.
- B. Source Limitations:
 - 1. Obtain primary Epoxy Terrazzo Flooring System materials including membranes, primers, vapor barrier primers, resins and hardening agents from a single manufacturer with proof of NTMA membership.
 - 2. Obtain aggregates, divider strips, sealers, cleaners from source recommended by primary materials manufacturer.
- C. Pre-installation Conference: Conduct conference at Project site to review methods and procedures related to terrazzo including, but not limited to, the following:
 - 1. Inspect and discuss installation procedures, joint details, jobsite conditions, depressed substrate specification, vapor barrier details, vapor barrier primers, and coordination with other trades.
 - 2. Review and finalize construction schedule and verify availability of materials, Installer's personnel, equipment and facilities needed to make progress and avoid delays.
 - 3. Review special terrazzo designs and patterns.
 - 4. Review dust control procedures.
 - 5. Review plans for concrete curing and site drying to enable timely achievement of suitable slab moisture conditions.
- D. NTMA Standards: Comply with NTMA's "Terrazzo Specifications and Design Guide" and with written recommendations for terrazzo type indicated unless more stringent requirements are specified.
- E. LEEDS NC: Submit certification from Manufacturers of all terrazzo flooring materials and accessories that products are sustainable products, listing all applicable LEED U.S. Green Building code council's credits made available by certification.
- F. SCAQMD: Floor coatings shall not exceed the VOC content limits established in South Coast Air Quality Management District (SCAQMD) Rule 1113, Architectural Coatings.
- G. Mockups: Build mockups to verify selections made under sample submittals and to demonstrate aesthetic effects and set quality standards for materials and execution.
 - 1. Build mockups for terrazzo including accessories.
 - a. Size: Minimum 100 sq. ft. of typical poured-in-place flooring condition for each color and pattern in locations directed by Architect.
 - 2. Approved mockups may become part of the completed Work if undistributed at time of Substantial Completion.

1.05 DELIVERY, STORAGE AND HANDLING

- A. Deliver materials to Project site in supplier's original wrappings and containers, labeled with source's or manufacturer's name, material or product brand name and lot number if any.

- B. Store materials in their original, undamaged packages and containers, inside a well-ventilated area protected from weather, moisture, soiling, extreme temperatures and humidity.
 - 1. Storage temperatures should be between 60°F to 80°F.

1.06 PROJECT CONDITIONS

- A. Terrazzo contractor shall, prior to surface preparation:
 - 1. Evaluate depressed slab condition, including slab moisture content and extent of repairs required, if any.
 - 2. Maintain the ambient room and floor temperature at 60°F or above for a period extending 72 hours before, during and after floor installation. Concrete to receive epoxy terrazzo shall have cured for at least 28 days and be free of all curing compounds. Test concrete substrate to determine acceptable moisture levels prior to installation. Testing should be conducted according to ASTM F2170 (determining relative humidity in concrete slabs using in situ probes).
- B. Prior to and during each day of installation, the terrazzo contractor shall verify that the dew point is at least 5°F less than the slab and air temperature.
- C. Acceptable Substrates:
 - 1. Depressed concrete sub-floor at all terrazzo locations, confirm and verify depth.
 - 2. Level tolerance: Concrete sub-floor shall be level with a maximum variation from level of 1/4" in 10 feet. Any irregularity of the surface requiring patching and/or leveling shall be done using the manufacturer's fill of selected aggregates as recommended by manufacturer.
 - 3. Concrete floor shall be prepared mechanically by shot blasting in accordance with ICRI Guideline No. 03732. Specifically, surface preparation results should achieve a CSP3-CSP5 profile.
 - 4. Concrete floor shall receive a steel trowel finish.
 - 5. Concrete shall be cured a minimum of 28 days. No curing agents are to be used in areas to receive terrazzo.
 - 6. Concrete slab shall have an efficient moisture vapor barrier directly under the concrete slab. Moisture vapor barrier shall be an approved puncture resistant polyethylene sheet not less than 15 mils thick, in compliance with 03200 requirements. Moisture barrier shall NOT be punctured.
 - 7. Saw cutting of control joints must be done between 12 and 24 hours after placement of the structural concrete and at a frequency compatible to ACI recommendations.
- D. Provide permanent lighting or, if permanent lighting is not in place, simulate permanent lighting conditions during terrazzo installation.
- E. Provide protection from other trades prior to final acceptance by Owner.

PART 2 – PRODUCTS

2.01 EPOXY TERRAZZO

- A. Products Systems Overview: The basis of design and specifications are an 800 grit finish product manufactured by Terroxy® Resin Systems Epoxy Matrix by Terrazzo & Marble Supply Companies, Wheeling, IL (www.tmsupply.com) Equal system by General Polymers from Sherwin Williams or Master Terrazzo Technologies or others will be accepted provided each is pre-approved by Architect in accordance with the General Conditions.
- B. Materials:
 - 1. Vapor Barrier Primer (required throughout): Terroxy® Moisture Vapor Primer (for new or existing slabs on-grades, slab-on-decks, or light-weight and green concrete).
 - a. Physical properties of moisture mitigating primer shall have a maximum of 0.3 perms with 100% RH.
 - 2. Flexible Reinforcing Membrane: Terroxy® Iso-Crack Epoxy Membrane, for substrate crack preparation and reflective crack reduction.
 - a. Provide for a minimum of 10% for the project
 - b. Reinforcement: Fiberglass scrim.
 - 3. Epoxy Matrix: Terroxy® Epoxy Matrix and in color required for mix indicated.

- a. Physical properties without aggregates. All specimens cured for 7 days at 75°F plus or minus 2°F and 50 percent plus or minus 2 percent RH. This product shall meet the following requirements:

Property	Test Method	NTMA Requirements	Thin-set Epoxy Terrazzo Typical Results
Hardness	ASTM D-2240 using Shore-D Durometer	60-85	75-85
Tensile Strength	ASTM D-638	3,000 psi min.	4,800 psi min.
Compressive Strength	ASTM D-695 Specimen B cylinder	10,000 psi min.	12,000 psi min.
Flexural Strength	ASTM D-790	Not specified	4,500 psi min.
Chemical Resistance	ASTM D-1308 seven days at room temperature by immersion method	No deleterious effects: <ul style="list-style-type: none"> ▪ Distilled Water ▪ Mineral Oil ▪ Isopropanol ▪ Ethanol ▪ 0.025 Detergent Solution ▪ 1% Soap Solution ▪ 10% Sodium Hydroxide ▪ 10% Hydrochloric Acid ▪ 30% Sulfuric Acid ▪ 5% Acetic Acid 	No deleterious effects: <ul style="list-style-type: none"> ▪ Distilled Water ▪ Mineral Oil ▪ Isopropanol ▪ Ethanol ▪ 0.025 Detergent Solution ▪ 1% Soap Solution ▪ 10% Sodium Hydroxide ▪ 10% Hydrochloric Acid ▪ 30% Sulfuric Acid ▪ 5% Acetic Acid

- b. Physical properties with aggregates. For Epoxy Matrix blended with three volumes of Georgia White marble blended 60% #1 chip and 40% #0 chip, ground and grouted with epoxy resin according to Installation Specifications, finishing to a nominal 3/8" thickness. All specimens cured for 7 days at 75°F plus or minus 2°F and 50 percent plus or minus 2 percent RH. This finished Epoxy Matrix shall meet the following requirements:

Property	Test Method	NTMA Requirements	Thin-set Epoxy Terrazzo Typical Results
Flammability	ASTM D-635	Self-extinguishing, extent of burning 0.25 inches max.	Self-extinguishing, extent of burning 0.25 inches max.
Thermal Coefficient of Linear Expansion	ASTM D-696	25x10 ⁻⁶ inches per inch per degrees to 140°F	25x10 ⁻⁶ inches per inch per degrees to 140°F
Bond Strength	ACI COMM 403, Bulletin 59-43 (pages 1139-1141)	300 psi (100% concrete failure)	300 psi (100% concrete failure)

4. Aggregate Chips Mix: Provide an aggregate chips mix from the Carolina Colors Collection, Premium Carolina Marble Terrazzo Chips.
5. Aggregates: Complying with NTMA gradation standards for mix indicated and containing no deleterious or foreign matter.
 - a. Obtain aggregates from a local regional source: Southern Aggregates, Staley, NC
 - b. Abrasion and Impact Resistance: Less than 40 percent loss per ASTM C 131.
 - c. 24-Hour Absorption Rate: Less than 0.74 percent.
 - d. Dust Content: Less than 1.0 percent by weight.

- e. Postindustrial Recycled Content: No less than NTMA minimum standard
- 6. Finishing Grout: Terroxy® Epoxy Matrix or Terroxy® Clear Resin as recommended by Terroxy® Resin Systems.
- C. Mix: Comply with NTMA's "Terrazzo Specifications and Design Guide" and manufacturer's written instructions for matrix and aggregate proportions and mixing.
 - a. Color and Pattern Schedule: When designations are indicated or scheduled, provide specified terrazzo matrices matching the Architect's approved samples:

2.02 STRIP MATERIALS

- A. Thin-set Divider Strips: L-type.
 - 1. Material: White-zinc alloy.
 - 2. Guide for commonly used L-type divider strips for Thin-set Epoxy Terrazzo Systems:

System Height	Strip Height	Strip Width
3/8" System	3/8"	16 gauge
		1/8"
		1/4"

- B. Control-Joint Strips: Separate double L-type angles back to back with minimum 1/8" width between. Fill area between strips with 100% solids epoxy filler. Match material, thickness and color of divider strips and depth required for topping thickness indicated.
- C. Isolation (Expansion) Joint Strips: Separate double L-type angles, positioned back to back with minimum 1/8" width between. Fill area between strips with Terroxy® Joint Filler. Match material, thickness and color of divider strips and depth required for topping thickness indicated.
- D. Accessory Strips: Match divider strip width, material and color unless otherwise indicated. Use the following types of accessory strips as required to provide a complete installation:
 - 1. Edge-bead for exposed edges of terrazzo.

2.03 MISCELLANEOUS ACCESSORIES

- A. Strip Adhesive: 100% solids epoxy resin adhesive recommended by Terroxy® Resin Systems.
 - 1. Use adhesive that has a VOC content of 50g/L or less when calculated according to 40 CFR 59, Subpart D (EPA Method 24).
- B. Anchoring Devices:
 - 1. Strips: Provide epoxy adhesive/mechanical anchoring devices for strip materials as required for secure attachment to substrate.
- C. Patching and Fill Material: Terroxy® Fill and selected aggregates as recommended by Terroxy® Resin Systems.
- D. Joint Compound: Terroxy® Joint Filler, color to be selected by architect to match/compliment terrazzo.
- E. Cleaner: Terroxy® Terra Clean, a neutral cleaner with pH factor between 7 and 10 specifically designed for terrazzo.
- F. Surface Finish System: Level of polish shall be an 800 grit minimum finish to match Architect's approved sample, with respect to and in accordance with desired appearance and level of reflectivity.
- G. Sealer: Slip- and stain-resistant sealer that is chemically neutral with a pH factor between 7 and 10, a standard coefficient of friction of 0.6 or higher, does not affect physical properties of terrazzo and complies with NTMA's "Terrazzo Specifications and Design Guide". Architect to final select from submitted data after review of manufacturer's recommendation.
 - 1. Terroxy® Acrylic Sealer, high performance, high gloss acrylic sealer; VOC content free, compatible with an 800 grit finish.

PART 3 – EXECUTION

3.01 EXAMINATION

- A. Examine depressed slabs, substrates and areas, with Terrazzo Contractor present, for compliance with requirements for installation tolerances and other conditions affecting performance.
- B. Proceed with installation only after unsatisfactory conditions, including level tolerances, have been corrected.

3.02 PREPARATION

- A. Clean substrates of substances, including oil, grease and curing compounds, that might impair terrazzo bond. Provide clean, dry and neutral substrate for terrazzo application.
- B. Concrete Slabs:
 - 1. Provide sound depressed concrete surface free of laitance, glaze, efflorescence, curing compounds, form-release agents, dust, dirt, grease, oil and other contaminants incompatible with terrazzo.
 - 1. Prepare concrete mechanically by shot blasting. Surface preparation results should achieve a CSP3-CSP5 profile according to ICRI Guideline No. 03732.
 - 2. Repair or level damaged and deteriorated concrete according to Terroxy® Resin Systems Technical Bulletin 008 Substrate Leveling Requirements for Terroxy® Thin-Set Epoxy Terrazzo
 - 3. Repair cracks and non-expansion joints greater than 1/16" (1.6 mm) wide according to Terroxy® Resin Systems Technical Bulletin 009 Crack Detailing and Joint Treatments for Terroxy® Resin Thin-set Epoxy Terrazzo.
 - 2. Verify that concrete substrates are visibly dry and free of moisture.
 - 3. Apply Terroxy® Moisture Vapor Primer to all concrete substrate surfaces complete. Apply to terrazzo substrates in accordance with manufacturer's written instructions.
 - 4. Moisture Testing:
 - a. Test for moisture according to ASTM F2170 (determining relative humidity in concrete slabs using in situ probes), with an in situ probe equivalent to the "RH BluePeg" distributed by Terrazzo & Marble Supply. Proceed with installation only after substrates have a maximum relative humidity measurement reading less than 80%. Re-apply vapor barrier primer as required to achieve relative humidity measurement reading less than 80%.
- C. Protect other work from dust generated by grinding operations. Control dust to prevent air pollution and comply with environmental protection regulations.
 - 1. Erect and maintain temporary enclosures and other suitable methods to limit dust migration and to ensure adequate ambient temperatures and ventilation conditions during installation.

3.03 EPOXY TERRAZZO INSTALLATION

- A. General:
 - 1. Comply with NTMA's written recommendations for terrazzo and accessory installation.
 - 2. Place, rough grind, grout, cure grout, fine grind and finish terrazzo in accordance with manufacturer's written instructions and NTMA's "Terrazzo Specifications and Design Guide."
 - 3. Ensure that matrix components and fluids from grinding operations do not stain terrazzo by reacting with divider and control-joint strips.
 - 4. Delay fine grinding until heavy trade work is complete and construction traffic through area is restricted.
- B. Thickness: 3/8"; depress concrete slab substrates accordingly.
- C. Flexible Reinforcing Membrane: (Provide for in bids a minimum of 10% of project square footage of crack isolation membrane)
 - 1. Membrane application for isolated cracking: Route out all cracks and fill with 100% solids epoxy filler. Apply Terroxy® Iso-Crack Epoxy Membrane (spread at 40 mils thickness) across the crack allowing 12 inches on either side. Imbed fiberglass scrim into wet membrane and saturate with additional membrane.
 - 2. Membrane application for extensive cracking or crack prevention: Route out all cracks and fill with 100% solids epoxy filler. Apply Terroxy® Iso-Crack Epoxy Membrane (spread

- at 40 mils thickness) over prepared substrate to produce full substrate coverage in areas to receive terrazzo.
- D. Vapor Barrier Primer: Apply to all terrazzo substrates according to Terroxy® Resin Systems Vapor Barrier Primer Product Data Sheet.
 - E. Strip Materials:
 - 1. Divider and Accessory Strips:
 - a. Install strips in adhesive setting bed without voids below strips or mechanically anchor strips as required to attach strips to substrate.
 - b. Control-Joint Strips: Separate double L-type angles back to back with minimum 1/8" width between. Fill joint with 100% solids epoxy filler. Fill area between strips with Terroxy® Joint Filler. Match material, thickness and color of divider strips and depth required for topping thickness indicated.
 - c. Isolation (Expansion) Joint Strips: Separate double L-type angles, positioned back to back with minimum 1/8" width between. Fill area between strips with Terroxy® Joint Filler. Match material, thickness and color of divider strips and depth required for topping thickness indicated.
 - F. Placing Terrazzo:
 - 1. Mix epoxy matrix with chips and fillers in ratios directed by Terroxy® Resin Systems matching a sample approved by Architect.
 - 2. Trowel apply terrazzo mixture over epoxy primer to provide a dense flat surface to top of divider strips. Allow to cure per Terroxy® Resin Systems recommendations before rough grinding.
 - 3. Rough Grinding:
 - a. Grind with 24 grit silicon carbide or D-36 Diamond matrix stones until all Terrazzo strips and marble chips are uniformly exposed.
 - b. Follow initial grind with 80 or finer grit stones.
 - G. Grouting:
 - 1. Cleanse floor with clean water and rinse.
 - 2. Remove excess rinse water by wet vacuum, dry and fill voids with Terroxy® Resin Systems Epoxy Matrix or Clear Resin.
 - 3. Allow grout to cure. Grout may be left on terrazzo until other trades work is completed.
 - H. Polishing:
 - 1. Grind with 50 or 60, 80 to 120 grit stones and then progressively finer stones until all grout is removed from surface. Repeat rough grinding, grout coat and polishing if large terrazzo chip voids exist after initial polishing.
 - 2. Continue grinding and polishing surface with diamond discs and pads to achieve a surface with a minimum of 70 percent aggregate exposure, and a 200 grit minimum polish.
 - 3. Progressively continue polishing steps with polishing pads of 220 grit 5-passes, 400 grit 5-passes, 800 grit 5-passes, until a final 800 minimum grit polish is produced. Between grits, thoroughly clean and mop slurry water. Provide and use Terrazzo and Marble Supply ET polishing pad on a Terrco 2100 machine or equivalent products.
 - 4. When the terrazzo floor is dry, and has been either dust mopped or vacuumed to remove any remaining dirt, a Scotch Guard or equivalent stone protector shall be applied with a micro-fiber mop and then burnished with a 3M or appropriate equivalent purple diamond pad, until proper finish is achieved. This step should be repeated twice for two coats of stone protector.

3.04 CLEANING AND PROTECTION (800 Grit Finish)

- A. Protection: Upon completion, the Work shall be ready for final inspection and acceptance by the Owner and Architect. Provide final protection and maintain conditions, in a manner acceptable to Terrazzo Contractor, that ensure terrazzo is without damage or deterioration.
- B. Sealers and wax coating products are not required for an 800 grit finish, and are not to be applied.
- C. When needed, add back gloss by buffing with purple pads.
- D. Periodic re-application of the 3-M Stone Hardener with a fiber mop may necessary, to restore gloss, then buffed.

END OF SECTION

RELATED DOCUMENTS:

The general provisions of the Contract, including General and Supplementary Conditions, and General Requirements, and Division 1 specifications that apply to the work specified in this Section.

PART I GENERAL

1.1 SECTION INCLUDES

- A. Provide acoustical ceiling and wall treatments for Band and Dance/Drama as indicated on Drawings, and shall be provided under the cash allowance listed in Section 01056 Allowances.

1.2 PERFORMANCE REQUIREMENTS

- A. Acoustical ceiling and wall treatment components meet Class 1(0-25) rating in accordance with ASTM E 84.

1.3 SUBMITTALS

- A. Product Data: Submit manufacturer's product data, including product specifications, installation instructions and maintenance directions.
- B. Samples: Submit 12 x 12 inch sample to show core material, edge and corner details, finish and mounting hardware, for approval by Architect.

1.4 DELIVERY, STORAGE, AND HANDLING

- A. Delivery: Deliver materials to site in manufacturer's original, unopened containers and packaging, with labels clearly indicating manufacturer and material.
- B. Storage: Store materials in a dry area indoors, protected from damage and in accordance with manufacturer's instructions.

1.5 PROJECT CONDITIONS

- A. Do not install ceiling and wall treatment until all wet work, such as plastering, concrete, and masonry, is completely dry, building closed in with operational HVAC system.
- B. Install ceiling and wall treatment at air temperature between 60 and 85 degrees F, at maximum relative humidity of 75 percent, and in an enclosed building.

PART II PRODUCTS

2.1 MANUFACTURERS

- A. Wenger Corporation, Owatonna, MN 55060, (800) 733-039
 - 1. Acceptable equivalent manufacturers: Equivalent products by Conwed Designscape

2.2 ACOUSTICAL CEILING AND WALL TREATMENT

- A. Convex Diffuser Wall Panels: Laminate of one layer of fiberglass mat saturated with fire retardant polyester resin, covered with a top coat of white gel-coat, .125" thick, molded in a one-piece polycylindrical convex shape. Internal barrel portion filled with 1-1/2" thick layer of glass fiber batts.
 - 1. Edges: Square with metal internal edge protection.
 - 2. Corners: Square with tailored joints

3. Reinforced corners with diagonal supports for secure anchoring with included mounting hardware.
 4. All materials: Class A requirements of NFPA 101 Life Safety Code Requirements
 5. Finish: Woven polyester fabric applied directly to face and forming a full finished edge with tailored edge. Class A Fabric meeting NFPA 101 Life Safety Code Requirements.
 6. Mounting: Metal wall brackets with panel mounted z-bracket.
 7. Sound Transmission Class (STC): ASTM E 90 and ASTM E 413: 23
 8. Colors: Architect to select colors from all manufacturer's available colors
 9. Three-year warranty
- B. Flat Absorber Acoustical Wall Panels: One piece of 6 pcf noncombustible and dimensionally stable glass fiber core laminated with 1/8 inch high impact resistant, 16 – 20 pcf molded glass fiber board, molded glass fiber board, 3 inches thick.
1. Edges: Chemically hardened edges.
 2. Corners: Square.
 3. Finish: Woven polyester fabric covering the face, all edges, and a return on the back of a minimum of 1-1/2 inches, Class A Fabric meeting NFPA 101 Life Safety Code requirements
 4. Mounting: Metal wall brackets with panel mounted z-bracket.
 5. Noise Reduction Coefficient (NRC), ASTM C 423: 1.31.
 6. Colors: Architect to select colors from all manufacturer's available colors
 7. Three-year warranty
- C. Convex Ceiling Diffusers:
1. Curved polycylindrical convex panels: Rigid, thermo-molded plastic, 0.125" material thickness with manufacturer's standard white, "lemon-peel" finish. Pre-finished with latex acrylic paint, color selected by Architect. Provide extra paint material for damage repairs.
 2. PVC/acrylic plastic to meet Class A flame spread and smoke developed requirements according to NFPA 101 Life Safety Code Requirements
 3. Edges and Corners: Square.
 4. Mounting is securely attached to lay-in ceiling grid clips. Provide manufacturer's lay-in hanger hardware safety cables assembly for 4-corner ceiling grid installations.
 5. Three-year warranty

PART III EXECUTION

3.1 EXAMINATION

- A. Inspect areas to receive ceiling and wall treatment. Notify Architect of conditions that would adversely affect the installation or subsequent utilization of the ceiling wall treatment. Do not proceed with installation until unsatisfactory conditions are corrected.

3.2 INSTALLATION

- A. Install ceiling and wall treatment at locations indicated on the drawings and in accordance with manufacturer's instructions.
- B. Do not install acoustical panels until building is closed in and HVAC system is operational, and humidity is within manufacturer's specified range.
- C. Install ceiling and wall treatment plumb, level, square, in alignment with adjacent work, and secure.
- D.

3.3 CLEANING

- A. Clean ceiling and wall treatment surfaces in accordance with manufacturer's instruction.

- B. Touch up any minor finish damage. Remove and replace work that cannot be successfully cleaned and repaired to permanently eliminate evidence of damage.
- B. Repair minor damaged surfaces as directed by Architect.

END OF SECTION

RELATED DOCUMENTS:

Drawings and general provisions of Contract, including General and Supplementary Conditions and Division-1 Specification sections, apply to work of this section.

PART 1: GENERAL

DESCRIPTION OF WORK:

Provide acoustical ceiling systems, complete as shown and as specified herein, including exposed tee suspension systems and acoustical lay-in boards.

Coordinate work with installation of air conditioning grilles and diffusers specified in Division 15B and with installation of lighting fixtures specified in Division 16.

INDUSTRY STANDARDS:

For listing of names of industry standard agencies mentioned by abbreviation in this section refer to Section 01068.

QUALITY ASSURANCE:

Manufacturers:

Standard: For purposes of designating type and quality for work in this Section, Drawings and Specifications are based on products by following manufacturers:

Ceiling Suspension Systems shall be by one of following, or equivalent by:

- Eastern Products Corp.
- Chicago Metallic Corp.
- Donn Products, Incorporated

Acoustical Tiles shall be Armstrong or equivalent products by:

- BPB
- Chicago Metallic Corp
- USG

Source: Products for use on this Project shall be of one Manufacturer for each function.

Shop Drawings: Indicate following:

Layout of inserts required for ceiling suspension system.

Reflected ceiling layouts for all areas to receive acoustical ceilings. Details of all connections to work of other trades.

Submit typical layout showing size and spacing of exposed grid and hangers as related to structural frame.

Samples: Submit samples of each acoustical unit, suspension system, and accessories.

Test Reports: Submit (in triplicate) copies of certificate of Flame Spread Class 25 rating under requirements of SS-S-118A, required for all acoustical units on Project.

Manufacturer's Data: Submit (in triplicate) Manufacturer's printed installation instructions for suspension system.

Warranty: Provide 15 year "humidity no-sag" manufacturer's warranty for tiles and grid system, warranted to replace tiles and damaged or defective system components at no cost to owner if tiles sag visibly within the warranty period. Warranty terms equivalent to Armstrong Humiguard Plus 15 year warranty.

PRODUCT HANDLING:

Delivery: Deliver acoustical ceiling boards to Project site in Manufacturer's original packages, with seals unbroken, with Manufacturer's name and contents legibly marked thereon and with testing laboratory labels where required.

Storage: Store ceiling tiles and boards in enclosed areas, with same temperature and humidity conditions as areas in which material is to be installed.

ENVIRONMENTAL CONDITIONS:

Building Conditions: Install acoustical materials only when normal temperature and humidity conditions approximate interior conditions that will exist when building is occupied. Building shall not be cold and damp, or hot and dry.

Glazing shall be in place and all exterior openings closed. All concrete, plastering and other wet work shall be complete and dry.

Provide heat and ventilation to maintain proper conditions before, during, and after acoustical work is performed.

PART 2: PRODUCTS

TYPES AND SYSTEMS: All acoustical materials shall be of types indicated by type numbers on Drawings, as follows:

Type 1: 24" x 24" x 5/8" Armstrong fine fissured Humiguard Plus, RH90 No. 1728 / Prelude XL Grid

Type 2: 24" x 24" x 5/8" Armstrong fine fissured tegular edge Humiguard Plus, no. 1732 / Prelude XL Grid

Type 3: 24" x 24" x 5/8" Vinyl faced gypsum panels, with white stipple finish / AL Prelude Plus Grid

Type 4: 5/8" Moisture resistant gypsum board on hat channels/cold-rolled channels framing system.

Type 5: 5/8" Firecode gypsum board on hat channels/cold-rolled channels framing system. Smoke resistant construction.

Type 6: 5/8" Gypsum board on hat channels/cold-rolled channels framing system.

Type 7: Metal Panel Cloud Ceiling System: Armstrong FeltWorks Blades – HookOn Ebbs and Flows Pattern 1, W 192" x L 92" modules with 8" blade spacing, in manufacturer's standard colors / Armstrong Aluminum suspension Bar and aircraft cables.

Types 1 and 2 ACT units shall carry a 15-year warranty for any sagging.

HANGERS:

Wire: No. 12 gauge galvanized steel.

SUSPENSION SYSTEM:

Components: System shall consist of main support tees, cross tees, splice clips, wall angles, and hold down clips.

Design Loads: Suspension system shall be designed to support respective lay-in units and light fixtures with deflection of suspension members not to exceed 1/360 of span of member.

Exposed Grid System: Armstrong Exposed Grid System (hot dipped galvanized steel), consisting of main tees and cross tees with 15/16" exposed flange. Wall molding shall be cold-rolled galvanized steel, channel shaped, with 1" exposed face of same finish as exposed tee surfaces.

Provide all aluminum grid at AL grid locations indicated.

Provide bullnosed preformed corners for bullnosed wall corners.

Finish: Exposed surfaces of tees and of wall moldings shall be flat white, baked polyester.

PART 3: EXECUTION

INSTALLATION OF ACOUSTICAL CEILING SYSTEMS:

General Requirements:

Suspension System: Install strictly according to approved Shop Drawings layouts for spaces and manufacturer's printed instructions.

Ceiling Tile Pattern, Layout, and Type:

1. Install acoustical ceiling in patterns and types indicated on approved shop drawings and, as described in this specification.
2. Unless indicated otherwise herein or on Drawings, ceilings shall be laid out symmetrically in each space, with no less than half size panels or tiles at walls.

Installation of acoustical materials and suspension systems shall be made by experienced mechanics in strict accordance with Manufacturer's written instructions.

Fit parts neatly and accurately, true to line and plane.

Where hangers fall at structural members, install hanger clips in strict accordance with written instructions of Manufacturer of hanger clips.

Suspension system, including wall mold, shall be level to within 1/8" in 12 feet, with ceiling panels in place.

Exposed grid members shall be straight and in alignment. All exposed surfaces shall be flush and level.

General Requirements for Acoustical Ceilings:

Scribe lay-in units neatly to abutting surfaces and to penetrations or protrusions.

Exercise care to prevent soiling of ceiling tiles during installation. Leave entire system neatly and accurately fitted.

CLEANING: Following installation, clean all soiled and discolored surfaces. Remove and replace units, which are damaged or improperly installed.

EXTRA STOCK: Furnish Owner 5% of each pattern of acoustical tile installed in Project for maintenance replacements.

END OF SECTION

RELATED DOCUMENTS:

Drawings and general provisions of Contract, including General and Supplementary Conditions and Division-1 Specification sections, apply to work of this section.

GENERAL:

Stone Association Publications: Comply with recommendations contained in the publications indicated below:

Submittals: With manufacturer's data and installation instructions, submit samples not less than 12" x 12" for each type, color, and finish of stonework units.

PRODUCTS:

Obtain each type of stone from one quarry, with consistent color range and texture, complying with referenced ASTM standards and other references indicated, extracted from a single bed of quarry stratum.

Bluestone Slate: Where indicated on Drawings, provide blue-gray slate window stools and benches as detailed, exposed finished surfaces flat with buffed natural cleft face, one long edge sandrubbed, gauged, and slightly rounded front edge, with exposed edges true, level and square. Equivalent to Buckingham Slate Bluestone window sill stools.

Face Finish: Natural cleft face; buffed dull sheen, without reflections. Color and finish to match Architect's sample. Seal stone with manufacturer's recommended sealer.

Outside 90 degree corners directly adjacent to pedestrian walkway areas, shall be safety bullnosed.

Joints shall be colored mortar or grout. For colored pointing mortar, use ground granite or other sound stone to match Architect's sample.

Dry Set Thin-Set Mortar: ANSI A118.1

Prepackaged dry mortar mix with re-emulsifiable powder as additive, for mixing with water only.
Anchors: Nonferrous metal, as required to suit stone installations.

Fabrication: Precut stone units to required sizes and shapes. Use powered masonry saw for cutting units at site. Avoid use of less-than-half-size units.

INSTALLATION:

General: Do not use stone units with chips, cracks, voids, stains or other surface defects visible in finished work. Clean stone before setting by scrubbing with fiber brushes and water. Wet stone, as required, before setting. Comply with manufacturer's instructions for application of proprietary materials.

Seal exposed surfaces with manufacturer's recommended sealer.

Installation of Interior Wall Facing and Trim: Erect interior wall facing and trim, plumb and true with joints uniform in width and accurately aligned.

Install stone to comply with requirements of referenced ANSI installation specification, and of ANSI A108.10 and TCA "Handbook for Ceramic Tile Installation", respectively, for setting bed type, TCA installation method and grout: Dry-Set Portland Cement Mortar: ANSI A108.5

END OF SECTION

RELATED DOCUMENTS:

Drawings and general provisions of Contract, including General and Supplementary Conditions and Division-1 Specification sections, apply to work of this section.

PART 1 - GENERAL

1.01 DESCRIPTION

- A. A multipurpose sports floor system, a seamless pad and pour indoor sports flooring surface, comprised of a 7mm high-performance resilient base mat laid in a two-component polyurethane adhesive coat and a two-component polyurethane surface coat that is field applied in a seamless monolithic application. Total system profile height shall be **9mm**.

1.02 QUALITY ASSURANCE

- A. System basis of design is GameCourt, by Moose Sports Surfaces, Ltd. All system component parts must be GameCourt materials supplied by Moose Sports Surfaces, Ltd.
- B. The flooring contractor is required to be a manufacturer's certified installer approved by Moose Sports Surfaces, Ltd. .
- C. Flooring system shall be independently verified to meet or exceed the SCORES criteria for environmental design and athletic performance. Sustainable Construction Of Renewable Engineered Surfaces.
- D. FloorScore – Indoor Air Quality Certified to SCS-EC10.3-2014 v3.0. Conforms to the CDPH/EHLB Standard Method v1.1-2010 (California Section 01350), effective January 1, 2012, for the school classroom and private office parameters when modeled as Flooring. Registration # SCS-FS-04375.
- E. Accredited “Ecospecifier” product for achievement of Green Building Rating Tool Credits.

1.03 WORKING CONDITIONS

- A. Synthetic materials specified herein shall not be installed until all masonry, painting, plaster, tile, marble and terrazzo work is completed, and overhead mechanical trades, and painters have finished in the synthetic floor area. The building must be reasonably dry; all openings must be closed in; permanent heating and air conditioning installed and working before, during, and after installation.
- B. The general contractor / owner shall provide an area where the stored materials can be maintained at a minimum of 65 degrees and under 80% relative humidity. Ideal installation and storage conditions are the same as those that will prevail when the building is occupied.
- C. Others will provide a concrete sub floor to the flooring contractor finished, steel toweled, and level to 1/8” in any ten-foot radius. High spots shall be ground level and low spots filled with an approved leveling compound. No concrete curing or hardening agents shall be applied to the concrete sub floor. The concrete shall be clean, flat, dry, and free from dirt, dust, oil, grease, paint, alkali, and concrete curing agents, hardening and parting compounds, old adhesive residue, or other foreign materials.
- D. Flooring installation shall not begin until all sub-contract work is completed that would cause damage, dirt, dust, or interruption of normal installation. The installation area shall be closed to all traffic and activity for a period to be set by the flooring contractor.
- E. ENVIRONMENTAL LIMITATIONS
 - 1. Comply with requirements of athletic flooring material manufacturer.
 - 2. Adhere to all MSDS requirements for materials. Protect all persons from exposure to hazardous materials.
- F. Protect the work during and after the installation process, until acceptance by the owner or agents.

1.04 WARRANTY

- A. MATERIALS WARRANTY: Moose Sports Surfaces, Ltd. , warrants that the GameCourt flooring materials it shipped for installation at (the “Project”) will be free from defects for a period of 25 years. The sole and exclusive remedy under this materials warranty shall be the replacement

of defective materials by Moose Sports Surfaces, Ltd.y, and repair of any damages to flooring resulting directly from defective materials.

- B. **INSTALLATION WARRANTY:** The flooring installer “Installer” warrants that the installation of the flooring at the Project will be free from defects in workmanship and in any materials originating with flooring installer (such as, for example, subflooring) for the Warranties Period. The sole and exclusive remedy under this installation warranty shall be repair of damages to floor resulting directly from a defective installation, or defective materials originating with Installer, and replacement of any materials resulting from a defective installation.
- C. This warranty does not cover damage caused by fire, winds, floods, chemicals, or other abuse, or by failure of other contractors to adhere to specifications, or neglect of reasonable precautions to provide adequate ventilation during hot, humid weather. This warranty also excludes damage to floors due to ordinary wear and tear, faulty construction of the building (other than the flooring contractor), separation of the concrete slab underlying the floor, settlement of the walls, or use of unapproved cleaners or sealers on the floor.

PART 2 - PRODUCTS

2.01 MATERIALS

- A. All polyurethane components shall be GameCourt materials supplied by Moose Sports Surfaces, Ltd..
 - 1. Equivalent products and systems by Action Floor Systems LLC will be accepted.
 - 2. Equivalent products and systems by Robbins Sports Systems will be accepted.
- B. GAMECOURT PRIMER shall be a one-component polyurethane.
- C. GAMECOURT BASE MAT ADHESIVE, two-component polyurethane, shall bond rubber base mat to concrete, asphalt, or wood. It shall be applied at a rate of approximately .2/lbs / cubic foot minimum.
- D. BASE MAT
 - 1. Base mat shall be 7mm prefabricated rubber mat made of all recycled rubber granules bound with MDI polyurethane and manufactured to a constant thickness. The base mat shall have a density of 45-lbs. / cubic foot minimum.
- E. GAMECOURT SCRATCH COAT (mat sealer), two-component, thixotropic polyurethane compound applied at a rate of 0.18 lbs. / cubic foot.
- F. GAMECOURT WEAR COAT, two-component, pigmented, self-leveling polyurethane compound applied monolithically over the base mat to a 2mm thickness throughout. Color to be manufacturer’s standard color.
- G. GAMECOURT WATER BASED TOP COAT, matte-finish two-component polyurethane applied at a rate of 0.03lbs. / square foot. Colors to be selected from manufacturer’s standard color chart.
- H. GAMECOURT Game Line Paint shall be two-component polyurethane. Colors to be selected from standard colors.
- I. Tested per EN and DIN. No single point best results are acceptable.
- J. Technical Information:

Force Reduction	ASTM F2772-11	7+2 Class 2
Ball Rebound	ASTM F2772-11	>90%
Vertical Deformation	ASTM F2772-11	Passed
Surface Hardness	ASTM D-2240	Shore 80 A +/-
Tensile Strength	ASTM D412	88 psi
Elongation at Break	ASTM D412, Die Cast C	48.5%
Tear Strength	ASTM D624, Die C	30 ppi
Flammability	ASTM E648	Class 1 / Radiant Panel
- K. Floor Score: Measured Concentration of Total Volatile Organic Compounds (TVOC): Less than/equal to 0.5 mg/m3 (in compliance with CDPH/EHLB Standard Method v1.1-2010).

PART 3 - EXECUTION

3.01 INSPECTION

- A. Inspect concrete slab of proper tolerance and dryness, reporting in writing any discrepancies to the general contractor, architect, and/or owner.
- B. All work required to put the concrete slab in acceptable condition for installation shall be the responsibility of the general contractor.
- C. The slab shall be broom cleaned by the general contractor, free of all debris and/or contaminants.

3.02 INSTALLATION

- A. Concrete shall be clean and free of sealers, dirt, oil, paint, and any material that, in the opinion of the flooring installer, will adversely affect the material bonding to the concrete or the overall installation (refer to 1.03 Working Conditions).
- B. Primer: if specified or necessary, apply primer to substrate.
- C. Mix the two-component polyurethane adhesive per manufacturer's requirements and apply directly to the concrete sub-floor at the manufacturer's specified rate with the specified notched trowel.
- D. Immediately unroll pre-relaxed mat into freshly applied adhesive.
- E. Roll base mat with heavy flat roller.
- F. Thoroughly mix two-component scratch coat in accordance with manufacturer's requirements. Apply two coats of scratch coat to rubber base mat with a flat steel trowel. Allow each coat to cure before proceeding to the next application. After second coat has cured, inspect base mat for ridges and voids. Sand down ridges, and fill all voids as needed.
- G. Thoroughly mix two-component trowel coat in accordance with manufacturer's requirements. Apply mixed material using recommended notched trowel, or notched squeegee to a thickness of 2mm. Materials must be applied continuously to create a seamless surface. Allow topcoat to cure before proceeding to next step. Repair any imperfections in the finished surface. Clean floor with a vacuum, broom, or dry dust mop. Tack clean prior to proceeding.
- H. Thoroughly mix two-component polyurethane wear coat. Apply wear coat material with a high solvent resistant paint roller at the specified rate. Allow wear coat to cure before applying game lines.
- I. Using the highest quality masking tape, tape the floor. Thoroughly mix the two-component game line paint before use. Remove all game line tape prior to the paint curing.

3.03 CLEAN UP

- A. Clean up all unused materials and debris and remove.

3.04 MAINTENANCE

- A. New floor initial maintenance.
 - 1. **IMPORTANT** Allow new floor or newly recoated floor to cure at least 96 hours.
 - 2. Sweep floor thoroughly. Do not use sweeping compounds.
 - 3. Mix manufacturer's approved cleaner with clean water to achieve desired water-to-cleaner ratio.
 - 4. Using a new mop, damp mop the entire floor with cleaner/water mix.
 - 5. Allow solution to dry on floor prior to use.
- B. Upon completion of floor installation, the owners, attendants or individuals in charge and responsible for the upkeep of the building are to see that all care maintenance are followed in accordance with GameCourt guidelines. Failure to follow care and maintenance guidelines may void warranty.

3.05 PROTECTION

- A. Cure Time -- no traffic or trades shall be allowed on the surface for a period of one (1) week following completion to allow for complete and proper cure of the finish.
- B. Cure Time -- no heavy items or heavy installation (i.e. -- 10 row bleachers or above) for a period of four (4) weeks following completion to allow for complete and proper cure of the wear coat layer.
- C. Other Trades -- it is the responsibility of the General Contractor to protect the surface from damage by other trades before acceptance by the owner or the owner's authorized agent.
- D. After synthetic floors are installed and the game lines painted, area to be kept locked by general

contractor to allow curing time for system. No other trades or personnel are allowed on floor until accepted by owner.

- E. When subjecting the GAMECOURT[®] floor to significant rolling loads or heavy equipment such as scissor lifts, scaffolding, four-wheel dollies, etc. and/or point loads that exceed 250 PSI we recommend the following;
1. Provide a protective cover to prevent marring of the top coat finish. This may be accomplished with 6 mill poly, kraft paper, red rosin paper or standard protective gym covers.
 2. Provide a double layer of 5/8" (minimum) thick plywood or Masonite where equipment will travel across the floor system. Plywood may be "walked" across floor as equipment is moved to minimize number of sheets required. The upper and lower layers of the plywood must be staggered to eliminate end joints from aligning thereby reducing point loads to the system.

END OF SECTION

RELATED DOCUMENTS:

Drawings and general provisions of Contract, including General and Supplementary Conditions and Division-1 Specification sections, apply to work of this section.

PART 1: GENERAL

DESCRIPTION OF WORK:

Provide FloorScore certified resilient flooring systems as indicated, complete assemblies with wall base and transitions throughout, with all necessary profiles and accessories, for all conditions, as shown on Drawings and as specified herein.

Provide rubber tile, stair tread and nosing, riser, and stringer system complete assemblies with transitions and necessary accessories, as shown on Drawings and as specified herein.

Concrete floors are specified to be finished flat and level under Division 3 requirements.

Skim coat all areas to receive resilient flooring systems complete, with self-leveling smoothing and leveling compound and prepare for installation of finish products scheduled.

At all SOG (slab-on-grade) and SOD (slab-on-deck) areas, apply a moisture barrier primer/sealer coating to all new and existing concrete floor slab substrates complete.

INDUSTRY STANDARDS:

ASTM F 710-05

FloorScore Indoor Emissions Testing Program

For listing of names of industry standard agencies mentioned by abbreviation in this section refer to Section 01068.

QUALITY ASSURANCE:

Standard: For purposes of designating type and quality for work under this Section, Drawings and Specifications are based on products by following manufacturers or approved equal:

1. Luxury Vinyl Tile & Plank
 - a. Tarkett Event Series; Color/Design Lines: "Event Abstract" and "iD Latitude Abstract"
 - b. Dal-tile PRO SERIES Luxury Vinyl Flooring; Lofton Series Color/Design Lines: "Fabric" with ALL Accent Colors, "Limestone", and "Pines Terrace" Wood Look Planks
 - c. Mannington Diamond 10 Series equivalents
 - d. Mohawk Equivalents
2. 100% Vulcanized Thermoset Rubber Base and Accessories:
 - a. Roppe Rubber Company

- b. Flexco Division Textile Rubber Company
- c. Johnsonite Rubber Company

3. Rubber Tile, Stair Tread and Nosing, Riser, and Stringer system
 - a. Johnsonite Rubber Company
 - b. Roppe Rubber Company
 - c. Flexco Division Textile Rubber Company

SUBMITTALS:

Samples: Submit following samples of materials proposed for use.

Tile: Three sample tiles of each color selected.

Accessories: Three 12" lengths of each of the following:

1. Wall Base
2. Transition Edge Strip
3. Carpet Transition Stop / Reducer
4. Stair Tread and Nosing, Riser, and Stringer system
5. Self Leveling Skim Coating Material

Manufacturer's Literature: Submit (in triplicate) Manufacturer's certificates, MSDS sheets, VOC product data, and printed installation instructions on following:

- Smoothing and Leveling Compound
- Moisture Barrier Primer/Sealer
- Adhesive
- Resilient Flooring Materials
- Transition Strips
- Rubber Base

CERTIFICATES:

Submit certification from Manufacturer of each specific resilient material assembly, listing adhesives, primers and sealers for subfloors as proposed for use in conjunction with resilient material of this Section. Manufacturer of specific resilient material shall state approval of materials to be used with his materials as listed in certification.

Submit certification from Manufacturer of adhesive for each resilient flooring assembly, approving all primers and sealers proposed for use on new and existing concrete subfloors.

Submit certification from Manufacturer of each resilient flooring material assembly, approving floor leveler and/or floor patch material proposed for use on concrete subfloors.

Submit certification from Manufacturers of each resilient flooring material assembly, approving dry-cleaner and approving non-alkaline cleaning solution proposed for use on resilient flooring.

Submit certification from Manufacturers of all resilient flooring material assemblies that products are sustainable FloorScore certified products, are ortho-phthalate-free, and are CDPH Certified asthma and allergy friendly.

Submit certification from Manufacturers of resilient flooring adhesives are FloorScore certified products.

PRODUCT HANDLING:

Store resilient flooring materials as packaged by Manufacturer, in undamaged condition, and with Manufacturer's seals and labels intact. Exercise care to prevent damage and freezing during delivery, handling, and storage. Store materials at Project site at least 24 hours to their installation.

ENVIRONMENTAL CONDITIONS:

Temperature: Materials and area in which materials are to be installed shall be maintained at following temperatures:

For at least 24 hours before installation of material, and continuing for at least 48 hours after installation, maintain temperature at not less than 70 degrees F. to not more than 90 degrees F.

Maintain minimum temperature of 55 degrees F after flooring is installed.

PROTECTION:

Close spaces to traffic in which all resilient flooring is being set and to other work until flooring is firmly set. Where solvent-based adhesives are used, provide safety spark-proof fans and operate. Natural ventilation is inadequate. Smoking shall be prohibited.

MAINTENANCE MANUALS: Provide 3 copies of maintenance manuals for all resilient flooring describing maintenance procedures.

PART 2: PRODUCTS

SMOOTHING AND LEVELING COMPOUND:

Smoothing and leveling compound, provide complete on all concrete subfloors scheduled for resilient flooring systems. Ardex SD-L or equivalent self-leveling product as approved by flooring Manufacturer.

MOISTURE BARRIER PRIMER/SEALER:

Moisture barrier primer/sealer, required for all concrete subfloors, shall be as recommended by adhesives and flooring Manufacturer.

ADHESIVES:

Provide high moisture level rated adhesive for all concrete subfloors, for cementing resilient flooring materials to sub-floors, as approved by flooring Manufacturer.

Low emitting adhesive for wall base shall be as recommended by base Manufacturer.

All adhesives VOC content shall be less than 50g/L when calculated according to 40 CFR 59, Subpart D (EPA method 24).

All adhesives shall comply with requirements of the South Coast Air Quality Management District (SCAQMD) Rule #1168.

LUXURY VINYL TILE & PLANK

Provide Glue-Down 3 mm Luxury Vinyl Tile (LVT / LVP)) where indicated on Drawings.

Tarkett Event Abstract or iD Latitude Event Abstract Series

6 inch x 36 inch

18 inch x 18 inch

Dal-tile PRO SERIES Luxury Vinyl Lofton Series

6 inch x 24 inch

12 inch x 24 inch

24 inch x 24 inch

Provide 3 mm thick, ASTM F1700, Class III, Type B Embossed, ASTM D2047 Slip Resistant. Featuring 30 mil PVC wear layer thickness, with Tectonic polyurethane coating.

Resilient flooring of each color and pattern selected in any one area shall be from same lot.

Colors and Patterns: Colors will be selected by the Architect from Manufacturer's full product lines (including premium colors). Single unidirectional or block patterns will be selected for all spaces except classroom or lab spaces (classroom size); in classroom or lab size spaces, up to three colors may be selected in single unidirectional or standard block patterns, as directed by Architect.

Provide 20-year Commercial Warranty.

RESILIENT BASE:

Provide Rubber Wall Base where indicated on Drawings.

100% Vulcanized Rubber Base:

ASTM F 1861, Type TS, Group 1

Set cove type on hard surface and carpet flooring, 1/8" thick, 4" high at all places. Manufacturer shall offer minimum of 30 standard colors for selection by Architect, Roppe Rubber Co. or equal. Vinyl or part vinyl composition is not acceptable.

Provide pre-molded external corners at external 90 degree shaped corners. Base may be formed with continuous runs around bullnose profiled corners.

Provide pre-molded internal corners.

Provide pre-molded end stops.

RUBBER TRANSITION / REDUCER EDGE STRIPS:

Provide complete terminations at all type flooring transitions; to include all perimeters and terminations of all flooring, such as rubber or PVC sports flooring to VCT or polished concrete, carpet to VCT, epoxy

flooring to VCT, VCT or carpet to sealed or polished concrete. Vinyl profile thickness to account for actual flooring thicknesses.

Provide rubber transitions where non-level flooring surfaces meet or terminate. Must comply ADA Guidelines. Height to be coordinated with floor finishes thicknesses.

REDUCER STRIP: 1-1/4" wide with beveled edge, Johnsonite RRS-XX-D or equivalent. Color selected by Architect.

CARPET-TO-VCT TRANSITION STRIP: Johnsonite CTA-H adapter, or equivalent, color selected by Architect.

STAIR TREAD, RISER, STRINGER AND INTERMEDIATE LANDING TILE SYSTEM, AND INTERIOR RAMPS WHERE INDICATED:

Rubber stairwell intermediate landings shall be Johnsonite or equivalent Landing Tiles with a .187 thick round dot surface, overall size 24" x 24", color to be selected from manufacturer's standard colors. Provide where indicated.

Where scheduled, provide raised profile one piece stair tread and riser combination, shall be Johnsonite or equivalent VIRTR (for visually impaired) with a 2" wide contrasting strip of carborundum at the nose of the tread. Treads to have a tapering thickness gauge of .210" to .153" across a 13" tread width with a 7" integral riser, with a square nose and 2" hinged drop to accommodate riser angle. Provide matching rubber stringers. Color and profile to selected by Architect.

STAIR TREAD NOSING:

At stair treads or floor risers receiving VCT, provide profile of nosing that applies to and conforms to the actual stair tread/riser profile, Roppe No. 1 Commercial Stair Nosing or equivalent. Apply rubber base to face of stair riser or floor to conceal face of riser surface.

PART 3: EXECUTION

CONDITION OF SURFACES:

Requirements: Surfaces to receive resilient flooring shall meet minimum requirements established by ASTM F 710-05 and Manufacturer of flooring. Do not start work until defects have been corrected.

Obtain Architect's representative inspection of substrate prior to application of adhesives and tiles. Do not start work or continue work until inspection items have been corrected.

Tolerances: Subfloor surfaces shall not vary more than $\pm 1/8$ " in any ten-foot dimension. Neither shall they vary at rate greater than 1/16" per running foot. Unacceptable conditions shall be corrected by General Contractor.

APPLICATION OF SMOOTHING AND LEVELING COMPOUND:

Apply to cover substrate completely, wall to wall. Pour mixed compound onto substrate and steel trowel and/or float to spread to manufacturer's product minimum thickness ranges. Upon full cure, sand off entire surface and vacuum all areas.

APPLICATION OF PRIMER/SEALER:

Apply moisture barrier primer/sealer to cover substrate completely. Apply at rate recommended by Manufacturer of resilient flooring.

APPLICATION OF ADHESIVE:

Mix and apply adhesive in accordance with Adhesive Manufacturer's installation instructions. Cover surface evenly with adhesive. Area covered by one application of adhesive shall not exceed maximum working area recommended by Manufacturer. Install resilient flooring within time limits recommended by Manufacturer. If adhesive films over or dries, it shall be removed and area shall be recoated.

INSTALLATION OF RESILIENT TILE FLOORING:

Lay resilient flooring true, level; and with tight, aligned joints, roll flooring in accordance with Manufacturer's directions to assume intimate contact and proper adhesion. Cut resilient flooring to and around permanent cabinets and fixtures.

Align joints with room axis. Center tile work between walls. Except as required in irregularly shaped spaces, no tile shall be less than one half tile width. Lay tile with grain in direction or pattern as directed by Architect.

Obtain Architect's representative inspection of installation during installation phases. Do not start work or continue work until inspection items have been corrected.

INSTALLATION OF BASE:

Cement base firmly to wall. Joints shall be tight. Base (throughout its entire length) shall have top and bottom edges in firm contact with walls and finish floors. Form 90 degree internal and external corners and end stops from preformed units. Scribe base accurately to trim.

INSTALLATION OF EDGE STRIPS:

Install edge strips as required at doors and at other locations to provide transition from all finish flooring types to other floor areas of dissimilar materials.

CLEANING:

Immediately upon completion of stairwell rubber tile and tread system, clean floors and adjacent surfaces with cleaner approved by Manufacturer. Remove surplus adhesive and other soiling. Rinse thoroughly with clean, cold water.

LVP Post Installation Cleaning:

72 hours after initial installation, clean installed resilient flooring in strict accordance with manufacturer's written cleaning instructions, removing all stains and contaminants. Inspect surfaces for defects underneath tiles, visible tile deformations, and replace defective tiles as required. Sweep and protect, and maintain until building turnover to Owner.

EXTRA STOCK: Furnish Owner 5% quantity in unopened boxes of tile of each color and pattern installed, to be used in maintenance replacements.

END OF SECTION

RELATED DOCUMENTS:

Drawings and general provisions of Contract, including General and Supplementary Conditions and Division-1 Specification sections, apply to work of this section.

PART 1 - GENERAL

1.1 SUMMARY

A. Section Includes:

1. Industrial resinous flooring systems, with terminations, transitions, reducer strips.

B. Related Sections:

1. Section 07920 "Joint Sealants" for sealants installed at joints in resinous flooring systems.
2. Section 09650 Resilient Flooring, Rubber transitions/Reducer edge strips.

1.3 ACTION SUBMITTALS

- A. Product Data: For each type of product indicated. Include manufacturer's technical data, application instructions, and recommendations for each resinous flooring component required.
- B. Samples for Verification: For each resinous flooring system required, 6 inches square, applied to a rigid backing by Installer for this Project.
- C. Product should match existing quality, surface texture and visual appearance of existing work.
- D. Color Samples: Submit physical color samples for selection by Architect.

1.4 INFORMATIONAL SUBMITTALS

- A. Installer Certificates: Signed by manufacturer certifying that installers comply with specified requirements.
- B. Material Certificates: For each resinous flooring component, from manufacturer.
- C. Material Test Reports: For each resinous flooring system.

1.5 CLOSEOUT SUBMITTALS

- A. Maintenance Data: For resinous flooring to include in maintenance manuals.

1.6 QUALITY ASSURANCE

- A. Installer Qualifications: Manufacturer's authorized representative who is trained and approved for installation of flooring systems required for this Project.
 - 1. Engage an installer who is certified in writing by resinous flooring manufacturer as qualified to apply resinous flooring systems indicated.
- B. Source Limitations: Obtain primary resinous flooring materials, including primers, resins, hardening agents, grouting coats, and topcoats, from single source from single manufacturer. Provide secondary materials, including patching and fill material, joint sealant, and repair materials, of type and from source recommended by manufacturer of primary materials.
- C. Preinstallation Conference: Conduct conference at Project site.

1.7 DELIVERY, STORAGE, AND HANDLING

- A. Deliver materials in original packages and containers, with seals unbroken, bearing manufacturer's labels indicating brand name and directions for storage and mixing with other components.

1.8 PROJECT CONDITIONS

- A. Environmental Limitations: Comply with resinous flooring manufacturer's written instructions for substrate temperature, ambient temperature, moisture, ventilation, and other conditions affecting resinous flooring application.
- B. Lighting: Provide permanent lighting or, if permanent lighting is not in place, simulate permanent lighting conditions during resinous flooring application.
- C. Close spaces to traffic during resinous flooring application and for not less than 24 hours after application unless manufacturer recommends a longer period.

PART 2 - PRODUCTS

2.1 MANUFACTURERS

- A. Basis-of-Design Product: Subject to compliance with requirements, provide SoySTEP by Soy Resin Systems or pre-approved equivalent product.

2.2 MATERIALS

- A. Epoxy should be approved under MIL-Spec MIL-D-24613 Type III and be 100% solids, non-toxic containing no solvents or thinners. ROCK to RESIN RATIO MUST BE LESS THAN 3LBS OF AGGREGATE PER POUND OF EPOXY RESIN (EXCLUDING TOPCOAT).

- B. Select the desired color patterns consisting of marble, silica sand and quartz.
- C. Interior Adhesives and Sealants: Comply with and Meet SCAQMD #1168 and GS-36, adhesives and sealants do not contain carcinogen or reproductive toxicant components present at more than 1% of total mass as defined in the California Office of Environment Health Hazard Assessment's (OEHHA) list entitled "Chemicals Known to the State to Cause Cancer" or the Reproductive Toxicity, Safe Drinking Water and Toxic Enforcement Act of 1986 (PROPOSITION 65)
 - 1. Laboratory Test Reports: For floor systems, submit documentation indicating that the products comply with the testing and product requirements of the California Department of Health Services' "Standard Practice for the Testing of Volatile Organic Emissions from Various Sources Using Small-Scale Environmental Chambers".
 - 2. Product Data for Liquid Applied Flooring Components: provide documentation including printed statement of VOC content. SoyPoxy – VOC Label must not exceed 45 g/l.

2.3 INDUSTRIAL RESINOUS FLOORING

- A. Resinous Flooring: Abrasion-, impact- and chemical-resistant, industrial-aggregate-filled, resin- based, monolithic floor surfacing designed to produce a seamless floor and integral cove base.
- B. System Characteristics:
 - 1. Color and Pattern: SoySTEP by Soy Resin Systems
 - 2. Wearing Surface: Orange-peel
 - 3. Overall System Thickness: 1/8 inch
- C. Body Coats:
 - 1. Resin: SoyPoxy.
 - 2. Formulation Description: 100 percent solids.
 - 3. Application Method: Troweled.
 - a. Thickness of Coats: 1/8 inch.
 - b. Number of Coats: One.
 - 4. Aggregates: Marble, Silica Sand and Quartz
- D. Topcoat: Sealing or finish coats.
 - 1. Resin: Urethane.
 - 2. Formulation Description: Water based.
 - 3. Type: Clear.
 - 4. Finish: Epoxy.
 - 5. Number of Coats: One.
- E. System Physical Properties: Provide resinous flooring system with the following minimum physical property requirements when tested according to test methods indicated:

1. Compressive Strength: 17,800 psi after 7 days per ASTM C 579.
2. Adhesion Strength: ASTM-D-4541 >500 psi with 100% concrete failure.
3. Tensile Strength: 7,100 psi after 7 days per ASTM C 307.
4. Flexural Modulus of Elasticity: 10,000 psi after 7 days per ASTM C 580.
5. Coefficient of Linear Expansion: 2.5×10^{-5} per ASTM D-696.
6. Linear Shrinkage: ASTM C-531 <.02% Specifications for SoySTEP Flooring System
7. Water Absorption: <.2% per ASTM D-570.
8. Indentation: Shall not exceed 1 percent maximum per ASTM D-2794.
9. Impact Resistance: No chipping, cracking, or delamination per MIL-D-24613 ASTM D-2794 >24,000 psi..
10. Abrasion Resistance: MIL-D-24613, MIL-STD-1623 42 mg ASTM C-501 18mg.
11. Temperature Resistance ASTM D-2794 150-200 F No visible softening, cracking or delaminating.
12. Flame Spread MIL-D-24613, MIL-STD-1623 PASSED ASTM E-84 <3 Class A
Flammability ASTM D-570 Self Extinguishing Critical Rad Flux E-648 >1.07w/cm
13. Smoke Developed MIL-D-24613, MIL-STD-1623 PASSED Smoke Density ASTM E-662 <3.
14. Critical Radiant Flux: E-648 >1.07w/cm².
15. Odor ASTM D-2794 Free from objectionable odors.
16. Weight ASTM D-2794 1.2 lbs/ft² @ 1/8" thickness.
17. Hardness: At 14 days Shore D 80 per ASTM D 2240.

F. Chemical Resistance

Chemical Resistance @ 25°C (77°F) after curing 7 days

Duration in weeks	1	2	4	8
Distilled water	+	+	+	+
Sea water	+	+	+	+
Sulfuric acid, 30%	+	+	+	+
Sulfuric acid, 70%	+	+	+	+
Hydrochloric acid, 10%	+	+	+	+
Hydrochloric acid, 20%	+	+	+	+
Acetic acid, 5%	+	+	+	+
Ammonia, 10%	+	+	+	+
Toluene	a	a	a	a
MIBK	a	a	a	a
Ethanol, 50%	a	d	d	d
Gasoline, high test	+	+	+	+
Pine oil	+	+	+	+

+ = Resistant Film thickness 12 – 16 mils
a = Affected Cure Schedule 7 days at
21°C d = Destroyed Substrate, Sandblasted
steel

G. Provide rubber transitions and/or reducer edge strips at transitions to adjacent floorings.

H. Patching and Fill Material: Resinous product of or approved by resinous flooring manufacturer and recommended by manufacturer for application indicated.

PART 3 - EXECUTION

3.1 PREPARATION

- A. General: Prepare and clean substrates according to resinous flooring manufacturer's written instructions for substrate indicated. Provide clean, dry substrate for resinous flooring application.
- B. Concrete Substrates: Provide sound concrete surfaces free of laitance, glaze, efflorescence, curing compounds, form-release agents, dust, dirt, grease, oil, and other contaminants incompatible with resinous flooring.
 - 1. Repair damaged and deteriorated concrete according to resinous flooring manufacturer's written instructions.
 - 2. Alkalinity and Adhesion Testing: Verify that concrete substrates have pH within acceptable range. Perform tests recommended by manufacturer. Proceed with application only after substrates pass testing.
- C. Resinous Materials: Mix components and prepare materials according to resinous flooring manufacturer's written instructions.
- D. Use patching and fill material to fill holes and depressions in substrates according to manufacturer's written instructions.
- E. Treat control joints and other nonmoving substrate cracks to prevent cracks from reflecting through resinous flooring according to manufacturer's written instructions.

3.2 APPLICATION

- A. General: Apply components of resinous flooring system according to manufacturer's written instructions to produce a uniform, monolithic wearing surface of thickness indicated.
 - 1. Coordinate application of components to provide optimum adhesion of resinous flooring system to substrate, and optimum intercoat adhesion.
 - 2. Cure resinous flooring components according to manufacturer's written instructions. Prevent contamination during application and curing processes.
 - 3. At substrate expansion and isolation joints, comply with resinous flooring manufacturer's written instructions.
- B. Vertical Application:
- C. Integral Cove Base: Apply cove base mix to wall surfaces before applying flooring. Apply according to manufacturer's written instructions and details including those for taping, mixing, priming, troweling, sanding, and topcoating of cove base. Round internal and external corners.
 - 1. Integral Cove Base: **6 inches** high.
- D. Apply troweled body coats at 1/8" for flooring system. Hand or power trowel to fill voids. When cured, remove trowel marks and roughness using method recommended by manufacturer.

- E. Apply topcoats in number indicated for flooring system and at spreading rates recommended in writing by manufacturer.
- F.
- G. Install rubber transitions and/or reducer edge strips at transitions to adjacent floorings.

3.3 PROTECTION

- A. Protect resinous flooring from damage and wear during the remainder of construction period. Use protective methods and materials, including temporary covering, recommended in writing by resinous flooring manufacturer.

END OF SECTION 09671

RELATED DOCUMENTS:

The general provisions of the Contract, including General and Supplementary Conditions, and General Requirements, apply to the work specified in this Section.

PART 1: GENERAL

DESCRIPTION OF WORK:

Furnishing and installing all carpet scheduled on Drawings and specified in this Section. All carpet specified shall be manufactured with a static control system which reduces static generation below generally accepted sensitivity threshold of 3.0 kilovolts tested 20% relative humidity at 70 degree F. by "Shuffle" test.

INDUSTRY STANDARDS:

For listing of names of industry standard agencies mentioned by abbreviation in this Section, refer to Section 01068.

CRI Green Label Plus

South Coast Air Quality Management District

PRODUCTS:

Manufacturers:

Tarkett modular carpet tiles as specified/listed herein
Mohawk equivalent modular carpet tiles
Mannington equivalent modular carpet tiles

SUBMITTALS:

Manufacturer's Data: Submit for approval three copies of folder containing complete manufacturer's data and installation procedures for all materials to be used in work of this Section of specifications.

Samples: Submit for approval sample of each color carpet specified in squares at least 18"x 24".

Shop Drawings: Submit seam layout, diagramming location of all cuts, seams, rubber edge strips, and other pertinent installation details. Do not install carpet before receipt of written approval of Architect.

Guarantee: Submit written lifetime non-prorated guarantee to Owner, Architect, and General Contractor. Guarantee shall provide for replacement of all carpet installation, failing as result of faulty workmanship or materials, and shall explicitly include seam raveling. Carpet replacement shall be done at Owner's convenience and at no extra cost to Owner. Warranty to include replacement labor costs.

Lifetime warranty terms:

1. Wear: Lifetime of carpet. No more than ten percent (10%) face yarn loss.
2. Static: Lifetime of carpet.
3. Edge Ravel: Lifetime of carpet. Guaranteed no edge ravel in normal use.
4. Delamination: Lifetime of carpet. Guaranteed no delamination in normal use
5. Tuft Bind: Lifetime of carpet. Guaranteed not to zipper, wet or dry.
6. Backing Resiliency Loss: Lifetime of carpet.
7. Stain Resistance: Lifetime of carpet.

Certificate of Compliance: Submit to Architect with Shop Drawings, certificate, stating that carpet and allied products fully meet requirements of these specifications.

Submit certification from Manufacturers that carpet products are CRI Green Label Plus certified products.

Submit certification from Manufacturers that carpet adhesives are CRI Green Label Plus certified products.

PRODUCT HANDLING:

Deliver carpet to Project site in manufacturer's original protective wrapping.

Store carpet in area conditioned to temperature of areas scheduled to receive carpet.

PART 2: PRODUCTS

MATERIALS:

Direct Glue Down:

All materials shall be new and of domestic manufacturer. Carpet shall all be first quality. When, due to size, different dye lots are to be used, their location shall be approved by Architect.

TARKETT MODULAR TILE

Architect to select colors from:

2nd Power II #11648
Square Up #04990
Connectivity Style: Celestial #11688
Connectivity Style: Celtic Knots #11689
Discovery Style: Visual Path #11684
Discovery Style: Mentor #11686

CONSTRUCTION: Premium Grade, Textured Patterned Loop pile

FACE WEIGHT: 14 oz/sq. yd.
TRAFFIC CLASSIFICATIONS: Heavy, Education
GAUGE: 5/64 (50.4 rows per 10 cm)
STITCHES PER INCH: 10.0 per inch
TUFT DENSITY: 128 tufts/sq. in.
PILE HEIGHT AVERAGE: 0.187 inch
PILE THICKNESS: 0.078 inch
DENSITY FACTOR: 6,462 oz./cu. yd.
DYE METHOD: 100% Solution Dyed

WIDTH: 24" x 24" Modular Tiles, Unless Otherwise Noted

FIBER SYSTEM: Tarkett Dynex SD Nylon with Eco-Ensure Flourine-Free Soil Protection

BACKING SYSTEMS:

Modular Carpet Tiles: Tarkett ethos Modular with Omnicoat Technology – Pile tufts cast into synthetic non-woven molten thermoplastic resin, passing 20 lb. tuft bind test, carries lifetime non-prorated guarantee for edge ravel, back adhesion, and tuft bind.

Bonding Agent: 100% Renewable Bio-Based Resource (no latex or urethanes)

STATIC RESISTANCE: 3.5 KV or less under Standard Shuffle Test Method 70 degrees Fahrenheit.

FLAMMABILITY RATING:

1. Shall pass Methenamine Pill Test DOC-FF1-70.
2. Steiner Tunnel Test/ASTM-E-84:
Flame Spread: 45
Fuel Contributed: 35
Smoke Density: < 450 Flaming Mode, NBS Smoke Chamber NFPA-258
N.F.P.A. Class 1, ASTM E-648 glue down test
3. Critical Radiant Flux Test/ASTM-E-648, NFPA 253, and FTM 372.
Critical Radiant Flux: 0.22 or greater

ACCESSORIES:

Low Emitting Adhesives: Waterproof, non-flammable carpet adhesive recommended and approved by carpet manufacturer in writing for compatibility with carpet backing. All floor sealers, seam sealers, and adhesives shall contain no calculated solvents per OSHA Regulation 29 CFRE 1910.1200, have no calculated VOC's, be non-flammable (flame spread of 25 or less), and meet the criteria of the CRI Green Label Plus Certification Program. MSDS and samples required on product used.

Protection Paper: Fortifiber Corporation "Seekure 892", or approved heavy, reinforced, non-staining kraft laminated paper.

Low emitting seam adhesive shall be manufacturer's backing specific adhesive.

Provide manufacturer's extruded aluminum carpet stops, rubber reducer strips and rubber transition strips. Provide where carpet terminates at adjacent hard-surface floor finishes, concrete, terrazzo, and resilient flooring systems.

Apply moisture barrier primer/sealer coating to all existing concrete floor slab substrates complete. Moisture barrier primer/sealer, required for all existing concrete subfloors, shall be as recommended by adhesives and flooring Manufacturer.

Miscellaneous Materials: As recommended and approved in writing by manufacturer of carpet, and selected by Flooring Contractor to meet project circumstance and requirements.

ENVIRONMENTAL ATTRIBUTES

Environmental claims by manufacturer must comply with FTC guidelines.

Environmentally Preferred Product – Carpet must have third party certification (such as Scientific Certification Systems) in accordance with Executive Order 13101 as an Environmentally Preferred Product (EPP).

Rapidly Renewable Bio-based Materials: Carpet must contain a minimum 10% bio-based rapidly renewable material based on total product weight.

Carpet Face Yarn: In accordance with Executive Order 13101, carpet face yarn must be third party certified as an Environmentally Preferred Product (EPP).

Low Emitting Materials: Carpet and all installation components including adhesives, sealers, seam welds and seam sealers must meet the *Low Emitting Materials* standards as outlined in U.S. Green Building Council LEED criteria. Carpets should pass the CRI Green Label Plus Program in terms of VOC emissions. Adhesives must meet VOC emissions standards per South Coast Air Quality Management District Rule #1168.

End of Life Reclamation: Carpet must have an existing methodology actively in place to achieve landfill diversion. Refer to Section 3.03 of this section for specific requirements for reclamation of material.

PART 3: EXECUTION

CONDITION OF SURFACES:

Proper Surfaces: Inspect all surfaces to which carpet is scheduled to be installed. Do not start work until unsatisfactory conditions have been corrected. Starting of work in any area shall constitute acceptance of surface conditions. Carpet Contractor shall be held responsible for satisfactory installation.

INSTALLATION: (General)

Submit complete carpet mfg.'s installation instructions for approval by Architect. Carpet installation shall be supervised by a representative of the carpet mfg.

Install carpet with least seaming possible and with seams located parallel to line of traffic, where practical.

Except as otherwise approved on submitted shop drawings, all seams shall be made so that pile of adjoining pieces has same directional run, and so that seam is practically undetectable.

Cut neatly all openings in carpet for floor outlets and cover plates. Cut to minimum size, permitting cover-up by floor fixture.

SEAMING REQUIREMENT

In addition to the requirements and recommendations of the Carpet Manufacturer, the following criteria shall be adhered to:

1. Installation layout shall enable future replacement, especially in large open areas and traffic paths.
2. No carpet tile pieces smaller than 6" in width or length shall be used.
3. Seams occurring at doors of different types of carpet shall be parallel to closed door, and be centered directly under the closed door.

INSTALLATION: (Direct Glue Down)

All floors must be free of any foreign substance such as wax, oils, paint, etc. All cracks or irregularities must be smoothed with a latex base underlayment. Underlayment must be dry thoroughly before carpet is installed.

All carpeted areas shall be completely covered with an even coat of adhesive. Adhesive shall be spread with notched trowel (notches, 1/8" wide, 1/8" deep and spaced 1/8" apart) or equivalent.

All exposed edges of carpet that abut an adjacent floor surface of a different level shall be trimmed with edge stop as specified, securely fastened into subfloor.

All seams shall be trimmed filled in a workmanlike manner and shall be bonded at the time of installation with seam adhesive. This adhesive shall be applied to the cut edge of the carpet at the level of the carpet backing.

Where scheduled, carpet areas shall have a 4" high cove base.

CLEANING AND PROTECTION:

At completion of installation, carpet contractor shall clean up all debris, unusable scraps, and leave areas clean. Submit scraps to review by Architect for possible use as future replacement items.

Vacuum carpet using two motor, top loading, upright commercial machine with brush-only element, utilizing a high filtration dust bag. Remove spots in accordance with carpet manufacturer's guidelines and replace carpet where spots cannot be removed. Remove any protruding face yarn using sharp scissors, including all loose yarns or fibers at all seams.

Following cleaning and vacuum, carefully protect the carpeting from soiling and damage until final acceptance. Protection shall be accomplished by using approved protection paper. Edges shall be lapped 6 inches and secured with non-asphaltic tape. Covering shall be kept in repair and damaged portions replaced during the construction and move-in period.

Carpet determined by the Architect to be inadequately cleaned and not restored to like new condition or damaged due to inadequate protection, will be rejected and replaced.

MAINTENANCE MATERIALS:

Deliver 5% quantity, usable, uncut carpet tiles and broadloom carpet to Owner's designated storage space, properly packaged and identified. Dispose of smaller pieces as construction waste.

END OF SECTION

RELATED DOCUMENTS:

Drawings and general provisions of Contract, including General and Supplementary Conditions and Division-1 Specification sections, apply to work of this section.

PART 1 - GENERAL

SCOPE

This specification covers labor, materials, equipment, and application necessary for, and incidental to, the complete and proper installation of intumescent fire protection for application to steel structures and supports in accordance with all applicable requirements of contract documents.

This specification shall be supplemented by the applicable requirements of building codes, insurance rating organizations and all other authorities having jurisdiction.

SECTION INCLUDES

Intumescent fire protection material.

Topcoat protective decorative finish.

RELATED SECTIONS

Section 05120 - 05313: Structural Steel, Joists, and Decking.

Section 07256: Sprayed-On Fireproofing.

Section 09900: Painting.

REFERENCES

ULI – List of Equipment and Materials.

Intertek Testing Services/Warnock Hersey Certification Listing.

Test Standards:

- A. ANSI/UL 263 (ASTM E119 and NFPA 251) – Fire Tests of Building Construction and Materials.
- B. ASTM E84 – Surface Burning characteristics of Building Materials.
- C. ANSI/UL 1709 – Rapid Rise Fire Tests of Protection Materials for Structural Steel.

Steel Structures Painting Council (SSPC) Surface Preparation Standards.

Material manufacturer's current published information.

SYSTEM DESCRIPTION

The intumescent fire protection materials shall be applied at the required thickness to provide the fire resistance ratings for structural elements indicated on the drawings, per ITS or ULI Testing (columns and roof structure, 1 and 2 hour minimum).

SUBMITTALS

Manufacturer's Data: Submit manufacturer's specifications, including certification as may be required to show material compliance with contract documents.

Test Data: Submit certified copies of test designs from nationally certified testing laboratory verifying for protection applied to substrates and tested in accordance with Reference 1.4.3.A. and B.

Application Instructions: Submit manufacturer's application instructions.

QUALITY ASSURANCE

Manufacturer – Company specializing in manufacturing products of this section.

Applicator – A firm with expertise in the installation of fire protection or similar materials. This firm shall be approved by the fire protection material supplier.

Product – The product shall be approved by the architect and applicable authorities having jurisdiction.

DELIVERY, STORAGE AND HANDLING

Deliver materials to the project in manufacturer's unopened packages, fully identified as to trade name, type, and other identifying data. Packaging shall bear the ULI or ITS labels and seals for fire resistance ratings.

Store materials at a temperature above 40 degrees F (4 degrees C) in a dry location, protected from the weather.

Damaged packages found unsuitable for use and any materials which have come into contact with contaminants prior to use shall be rejected and removed from the project.

PROJECT/SITE CONDITIONS

When the temperature at the job site is less than 40 degrees F a minimum substrate and ambient temperature of 40 degrees F shall be maintained prior to, during, and a minimum of 24 hours after application. If necessary for job schedule, the General Contractor shall provide enclosures and heat to maintain proper temperatures and humidity levels in the application areas.

The General Contractor shall provide normal and or mechanical ventilation to allow proper drying of the intumescent and to ensure that a safe working area is achieved, during and after application.

In enclosed areas, ventilation shall not be less than 3 complete air exchanges per hour.

Intumescent fire protection shall not be applied until concrete toppings and or roofing applications have been installed, excluding steel columns to receive intumescent enclosed in CMU walls.

Relative humidity shall not exceed 80% throughout the total period of application and drying for the intumescent fire protection material, and must not exceed 80% throughout the application and drying for the protective decorative finish coat.

SEQUENCING AND SCHEDULING

Applicator shall cooperate in the coordination and scheduling of fire protection work to avoid delays in job progress.

The installation of piping, ducts, conduit, or other suspended equipment shall not commence until the application of the sprayed fire protection is complete in that area.

PART 2 – Products

PRIMER

Primer shall be approved by the manufacturer and applied in full accordance with the primer manufacturer's written instructions. Coordinate with steel fabricator prior to primer application on steel.

INTUMESCENT FIRE PROTECTION SYSTEM

The intumescent fire protection shall be Nullifire S606 as provided by Carboline Company, St. Louis, MO., or approved equivalent. Tested in ULI designs:

- X632 W-shape columns
- X633 Tube columns
- X634 Pipe columns

The intumescent fire protection for all exterior areas shall be Nullifire S605 exterior grade, specifically formulated and tested for exterior exposure, as provided by Carboline Company, St. Louis, MO., or approved equivalent. Tested in ULI in designs:

- X630 Tube columns

Intumescent fire protection material shall be applied in accordance with drawings and/or specification, and shall have been tested in accordance with ASTM E-119 in the Underwriter's Laboratory, Inc. and listed by U.L.I., and tested in accordance with REF. 1.4.3 A and B. 9 or equivalent nationally certified testing laboratory or Warnock Hersey. ULC is not acceptable.

TOPCOAT DECORATIVE COATING

Topcoat materials shall be as required for color-coding, aesthetics or additional surface protection, as supplied by Carboline Company, St. Louis, MO., or approved equivalent products meeting all compatibility requirements the approved intumescent products and tested in ULI assemblies.

No topcoats may be applied until qualified independent testing laboratory and AHJ has inspected and accepted installation.

PART 3 – Execution

PREPARATION

All surfaces to receive fire protection material shall be clean, dry, and free of oil, grease, loose mill scale, dirt, dust, or other materials, which would impair bond of the fire protection material to the surface. Any cleaning of the surfaces to receive fire protection material shall be the responsibility of the General Contractor or steel erector, as outlined in the structural steel section.

Confirm compatibility of surfaces to receive fire protection material. Steel surfaces shall be primed with a compatible primer recommended by the fire protection material manufacturer.

All unsuitable substrates must be identified and made known to the General Contractor and corrected prior to the application of the fire protection material.

The application of fire protection material shall not commence until certification has been received by the General Contractor that all surfaces to receive fire protection material have been inspected by the applicator and are acceptable to receive fire protection material.

Provide masking, drop cloths, or other suitable coverings to prevent over spray onto surfaces not intended to be sprayed.

APPLICATION

Application of intumescent fire protection shall not begin until the General Contractor is notified by the applicator that surfaces to receive fire protection have been inspected and are acceptable.

Equipment and application shall conform to the manufacturer's written application instructions.

The fire protection material shall be applied in sufficient thickness to achieve the required fire resistance rating with as many passes as necessary.

The fire protection material and the topcoat decorative finish shall be applied by spray, brush, or roller in shop or field.

Topcoat shall be applied according to the manufacturer's recommendations.

Proper temperature and ventilation shall be maintained as specified in 1.9.

MOCK UP

Before proceeding with the work, the applicator shall apply the fire protection material to a section as a mock up. This section shall be witnessed by the architect's or owner's representative and shall be subject to their approval to be used as a guide for texture, and thickness of the finish work.

CLEAN UP AND REPAIR

The work area shall be maintained in an orderly condition.

After the completion of work, equipment shall be removed and all surfaces not to be sprayed shall be cleaned to the extent previously agreed to by the applicator and the General Contractor.

Upon completion of installation, all excess material, over spray, dropping and debris shall be cleared and removed from the job site.

All patching of and repair to fire protection material , due to damage by other trades, shall be performed under this section and paid for by the trade responsible for the damage.

INSPECTION AND TESTING

In addition to continuous wet film thickness checks performed by the applicator during application, the installed intumescent shall be inspected by a qualified independent testing laboratory for thickness in accordance with the Steel Structures Painting Council (SSPC) Dry Film Thickness Testing.

The results of the above tests shall be made available to all parties at the completion of each area and approved prior to the application of topcoat.

END OF SECTION

RELATED DOCUMENTS:

Drawings and general provisions of Contract, including General and Supplementary Conditions and Division-1 Specification sections, apply to work of this section.

PART 1: GENERAL

DESCRIPTION OF WORK:

Extent of painting work is shown on drawings and schedules, and as herein specified.

The work includes painting and finishing of all interior and exterior exposed items and surfaces throughout project, except as otherwise indicated.

Surface preparation, priming and coats of paint specified are in addition to shop-priming and surface treatment specified under other sections of work.

"PAINT" as used herein means all coating systems materials, including primers, emulsions, enamels, stains, sealers and fillers, and other applied materials whether used as prime, intermediate or finish coats.

Paint all exposed surfaces, unless otherwise noted, whether or not colors are designated in "schedules", except where natural finish of material is specifically noted as a surface not to be painted. Where items or surfaces are not specifically mentioned, paint same as adjacent similar materials or areas. If color or finish is not designated, Architect will select these from standard light colors available for materials systems specified. Where indicated, "accent" colors are medium to deep shades, which shall require no more than one additional paint coat.

Following categories of work are not included as part of field-applied finish work, or are included in other sections of these specifications.

Shop Priming: Unless otherwise specified, shop priming of ferrous metal items is included under various sections for structural steel, miscellaneous metal, hollow metal work, and similar items. Also, for fabricated components such as architectural woodwork, wood casework, and shop-fabricated or factory-built mechanical and electrical equipment or accessories.

Pre-Finished Items: Unless otherwise indicated, do not include painting when factory-finishing or installer finishing is specified for such items as (but not limited to) metal toilet enclosures, prefinished partition systems, acoustic materials, architectural woodwork and casework, finished mechanical and electrical equipment including light fixture, switchgear and distribution cabinets, elevator entrance frames, doors and equipment.

Do not paint over any code-required labels, such as Underwriters' Laboratories and Factory Mutual, or any equipment identification, performance rating, name, or nomenclature plates.

SUBMITTALS:

Product Data: Submit manufacturer's technical information including paint label analysis and application instructions for each material proposed for use.

Samples: Submit samples for Architect's review of color and texture only. Provide a listing of material and application for each coat of each finish sample.

On 12"x12" hardboard, provide sample of each color and material, with texture to simulate actual conditions. On CMU face shell, provide sample of each color and material, with texture to simulate actual

conditions Resubmit samples as requested by Architect until acceptable sheen, color, and texture is achieved.

Wall Mockup: Paint 10'x10' section of wall with permanent lighting illumination for Architect's review and approval, prior to ordering paint materials.

Epoxy Paint Product Data: Epoxy paint manufacturer shall provide documentation that the epoxy product is tested and approved for application in such locations and for application on the surface material that is being used, and use is in compliance 2012 NC Building Code Sections 1210.2 and 1210.3; and in compliance with 2012 Plumbing code Sections 419.3 and 417.4.1 for providing smooth, hard non-absorbent surfaces adjacent to urinals and water closets and shower heads.

DELIVERY AND STORAGE:

Deliver materials to job site in original, new and unopened packages and containers bearing manufacturer's name and label, and following information:

- Name or title of material
- Fed. Spec. number, if applicable
- Manufacturer's stock number and date of manufacturer
- Manufacturer's name
- Contents by volume, for major pigment and vehicle constituents
- Thinning instructions
- Application instructions
- Color name and number

JOB CONDITIONS:

Apply water-base paints only when temperature of surfaces to be painted and surrounding air temperatures are between 50 degrees F (10 degrees C) and 90 degrees F (32 degrees C), unless otherwise permitted by paint manufacturer's printed instructions.

Apply solvent-thinned paints only when temperature of surfaces to be painted and surrounding air temperatures are between 45 degrees F (7 degrees C) and 95 degrees F (35 degrees C), unless otherwise permitted by paint manufacturer's printed instructions.

Do not apply paint in snow, rain, fog or mist; or when relative humidity exceeds 85%; or to damp or wet surfaces; unless otherwise permitted by paint manufacturer's printed instructions.

Painting may be continued during inclement weather if areas and surfaces to be painted are enclosed and heated within temperature limits specified by paint manufacturer during application and drying periods.

PART 2: PRODUCTS

COLORS AND FINISHES:

Color Pigments: Pure, non-fading, applicable types to suit substrates and service indicated.

Paint Coordination: Provide finish coats which are compatible with prime paints used. Review other sections of these specifications in which prime paints are to be provided to ensure compatibility of total coatings system for various substrates.

Federal Specifications establish minimum acceptable quality for paint materials. Provide written certification from paint manufacturer that materials provided meet or exceed these minimums.

Provide undercoat paint produced by same manufacturer as finish coats. Use only thinners approved by paint manufacturer, and use only within recommended limits.

EXTERIOR PAINT SYSTEMS:

- A. GALVANIZED METAL - (G60 Galvanized Steel; including Structural Steel Columns, Beams, Miscellaneous Structural Steel Members, Miscellaneous Steel Framing, Miscellaneous Stair & Ornamental Iron excluding treads, Catwalks excluding steel bar grating and treads, Fire Escapes, Hydrants). Note: G90 hot-dipped galvanized surfaces shall not be painted.

- 1. Acrylic Systems

- a. Gloss Finish

- i. Surface Preparation: Refer to Part 3 Surface Preparations of these specifications for Cleaning & Testing/Evaluations; Manufacturer's guidelines and recommendations stand as requirements of this work.
- ii. 1st Coat: S-W Pro-Cryl Universal Primer, B66-310 Series (10 mils wet, 4.0 mils dry film thickness)
- iii. 2nd Coat: S-W Sher-Cryl HPA High Performance Acrylic, B66-300 Series (10 mils wet, 4 mils dry film thickness)
- iv. 3rd Coat: S-W Sher-Cryl HPA High Performance Acrylic, B66-300 Series (10 mils wet, 4 mils dry film thickness)

- B. METAL - (Shop Primed Metal Doors and Frames/ Panels, etc.)

- 1. Acrylic Systems

- a. Gloss Finish

- i. Surface Preparation: Manufacturer's guidelines and recommendations stand as requirements of this work
- ii. 1st Coat: S-W Industrial Enamel Alkyd Gloss, B54-100 Series
- iii. 2nd Coat: S-W Industrial Enamel Alkyd Gloss, B54-100 Series (9 mils wet, 3.9 mils dry per coat)

INTERIOR PAINT SYSTEMS

- A. MASONRY/CONCRETE - (Walls & Ceilings, Concrete Beams, Concrete Roof Decks, Poured Concrete, Precast Concrete, Unglazed Brick or Block CMU, Cement Board)

1. Acrylic Enamel Systems

a. Semi-Gloss Finish

- i. 1st Coat: Loxon Block Surfacer, LX01W0200 (1 to 2 coats tinted and rolled in to fill all pits and pores completely, 16 wet mils, 8.8 dry mils).
- ii. 2nd Coat: S-W Pro-Classic Waterborne Acrylic, B31-1100 Series
- iii. 3rd Coat: S-W Pro-Classic Waterborne Acrylic, B31-1100 Series (4 mils wet, 1.3 mils dry per coat)

- B. WET AREAS - (All Food Service Area walls, All Toilets and Restrooms CMU walls and Gypsum Board Walls and Ceilings, All Shower Wall and Ceilings, All High Moisture Areas). NOTE: Epoxy paint manufacturer shall provide documentation that the epoxy product is tested and approved for application in such locations and for application on the surface material that is being used.

1. Epoxy Systems

a. Gloss Finish

- i. 1st Coat for Existing Walls Oil Based Painted: S-W Extreme Bonding Primer, B51W00150 (3.1 mils wet, 0.9 mils dry)
- ii. 1st Coat New CMU: S-W Loxon Block Surfacer, LX01W0200 (1 to 2 coats tinted and rolled in to fill all pits and pores completely, 16 wet mils, 8.8 dry mils).
- iii. 1st Coat New Gyp. Bd.: S-W ProMar 200 Zero VOC Latex Primer, B28W02600 (4 mils wet, 1.0 mils dry)
- iv. 2nd Coat: S-W Water Based Catalyzed Epoxy Gloss, B73-300 Series (8 mils wet, 4 mils dry)
- v. 3rd Coat: S-W Water Based Catalyzed Epoxy Gloss, B73-300 Series (8 mils wet, 4 mils dry)

- C. CONCRETE FLOORS – (Auditorium Floors, Shop Floors, Utility Equipment Platforms, Mezzanines, Custodial Spaces, Stairwells, Electrical Equipment Rooms, Boiler Rooms).

1. Urethane Systems

a. Gloss Finish (Clear)

- i. 1st Coat: Pressure wash, and SSPC prep
- ii. 2nd Coat: S-W Armorseal Rexthane I, B65-60 Series Gloss (3.0 – 4.5 mils wet, 2.0 – 3.0 dry)
- iii. 3rd Coat: S-W Armorseal Rexthane I, B65-60 Series Gloss (3.0 – 4.5 mils wet, 2.0 – 3.0 dry), (shop floors with anti-slip additive)

- D. METAL – (Structural Steel Columns, Joists, Trusses, Beams, Pipes, Miscellaneous Structural Steel Members, Miscellaneous & Ornamental Iron, Sashes, Doors, Door Frames, Partitions, Cabinets, Lockers, Radiators, Wall Louvers, Pumps, Motors, Machines, Convectors, Ducts [Ventilating], Electrical Raceways & Conduits, Elevator Cabs, Copper, Non-Galvanized Metal)

1. Alkyd Systems

a. Gloss Finish

- i. 1st Coat: S-W Kem Bond HS, Universal Metal Primer, B50 Series (10 mils wet, 3.8 mils dry film thickness)
- ii. 2nd Coat: S-W Industrial Enamel - Alkyd Gloss Enamel, B54-100 Series
- iii. 3rd Coat: S-W Industrial Enamel - Alkyd Gloss Enamel, B54-100 Series (9 mils wet, 3.9 mils dry per coat)

2. Dryfall Systems (EXPOSED CEILINGS; Structure, Ceilings, Ductwork, Conduits, where Scheduled)

a. Flat Sheen Finish

- i. 1st Coat: S-W Pro-Cryl Universal Primer, B66-310 Series (10 mils wet, 4.0 mils dry film thickness)
- ii. 2nd Coat: S-W Waterborne Acrylic Dry Fall, B42BW3 (9.0 mils wet, 3.5 mils dry)
- iii. 3rd Coat: S-W Waterborne Acrylic Dry Fall, B42BW3 (9.0 mils wet, 3.5 mils dry)

E. METAL - (Galvanized)

1. Alkyd Systems

a. Gloss Finish

- i. Surface Preparation: Refer to Part 3 Surface Preparations of these specifications for Cleaning & Testing/Evaluations; Manufacturer's guidelines and recommendations stand as requirements of this work.
- ii. 1st Coat: S-W Pro Industrial Pro-Cryl Primer, B66-1300 Series (10 mils wet, 3.8 mils dry film thickness)
- iii. 2nd Coat: S-W Industrial Enamel - Alkyd Gloss Enamel, B54-100 Series
- iv. 3rd Coat: S-W Industrial Enamel - Alkyd Gloss Enamel, B54-100 Series (9 mils wet, 3.9 mils dry per coat)

F. NON-TEXTURED SMOOTH DRYWALL (Walls, Ceilings, Gypsum Board, Wood Pulp Board, Plaster Board, Etc.)

1. Acrylic Enamel Systems

a. Semi-Gloss Finish (UNLESS NOTED OTHERWISE)

- b. FLAT SHEEN WHITE for drywall prosceniums, bulkheads, overhead drywall ceilings

- c. Base Coat: SHEETROCK Brand First Coat (drywall finishing surface coat for equalizing textures, coordinate with 09250)
 - i. 1st Coat: S-W Premium Wall & Wood Primer, B28W08111 (4 mils wet, 1.6 mils dry)
 - ii. 2nd Coat: S-W Pro-Classic Waterborne Acrylic, B31-1100 Series
 - iii. 3rd Coat: S-W Pro-Classic Waterborne Acrylic, B31-1100 Series (4 mils wet, 1.3 mils dry per coat)

G. CANVAS PIPE WRAP (exposed to view)

1. Latex Systems

a. Flat Finish

- i. 1st Coat: S-W PrepRite 200 Latex Primer, B28W200 (add fungicidal agent) (4 mils wet, 1.2 mils dry)
- ii. 2nd Coat: S-W ProMar 200 Latex Flat B30W200 Series (4 mils wet, 2 mils dry)
- iii. 3rd Coat: S-W ProMar 200 Latex Flat B30W200 Series (4 mils wet, 2 mils dry)

PART 3: EXECUTION

INSPECTION:

Applicator must examine areas and conditions under which painting work is to be applied and notify Contractor in writing of conditions detrimental to proper and timely completion of manner acceptable to Applicator.

Starting of painting work will be construed as Applicator's acceptance of surfaces and conditions within any particular area.

Do not paint over dirt, rust, scale, grease, moisture, scuffed surfaces, or conditions otherwise detrimental to formation of a durable paint film.

SURFACE PREPARATION:

General: Perform preparation and cleaning procedures in accordance with paint manufacturer's instructions, SSPC-SP, and as herein specified, for each particular substrate condition.

SSPC-SP: Steel Structures Paint Council Surface Preparation Specification

Clean surfaces to be painted before applying paint or surface treatments. Remove oil and grease prior to mechanical cleaning. Program cleaning and painting so that contaminants from cleaning process will not fall onto wet, newly-painted surfaces.

Wood: Clean wood surfaces to be painted. Remove dirt, oil, or other foreign substances with scrapers, mineral spirits, and sandpaper, as required. Sandpaper smooth those finished surfaces exposed to view, and dust off. Scrape and clean small, dry, seasoned knots and apply a thin coat of white shellac or other

recommended knot sealer, before application of priming coat. After priming, fill holes and imperfections in finish surfaces with putty or plastic wood-filler. Sandpaper smooth when dried.

Ferrous Metals: Clean ferrous surface, which are not galvanized or shop-coated, of oil, grease, dirt, loose mill scale and other foreign substances by solvent or mechanical cleaning.

Touch-up shop-applied primed coats wherever damaged or bare, where required by other sections of these specifications. Clean and touch-up with same type shop primer.

Galvanized Surfaces:

Hot-Dipped Galvanizing: Allow hot-dipped galvanized items to weather 6 months prior to surface preparations, and then steam clean per SSPC-SP 1. Do not use hydrocarbon solvents, vinegar or other mild acids for cleaning hot dipped galvanized surfaces. After cleaning, perform spot testing for any manufacturer's pre-treatments, using the procedure from ASTM D2092, Method B201, Volume 06.01. After pre-treatments testing, apply 2' x 2' paint test patch for evaluation of paint surface adhesion. Evaluate the adhesion at three locations of the surface area, by performing a tape adhesion test per ASTM Method D3359. Grade the tape adhesion of the coating by following ratings as set forth in ASTM D3359-97.

Galvalume: Clean free of grease, oil, dirt, soil, and other surface contaminants with hydrocarbon free solvent cleaner. Perform a light brush blasting per SSPC-SP7 if necessary. After cleaning, apply 2' x 2' paint test patch for evaluation of paint surface adhesion. Evaluate the adhesion at three locations of the surface area, by performing a tape adhesion test per ASTM Method D3359. Grade the tape adhesion of the coating by following ratings as set forth in ASTM D3359-97.

Special Food Service Area Wall Preparation: Special preparation will be required to assure that required Food Service area CMU wall surfaces are pointed and patched in strict accordance with the drawing's CMU surface preparation General Notes for on-site approval by local Health Department. All work resulting from inspection comments and requirements are to be provided at no additional cost.

Previously Coated Surfaces:

Maintenance painting will frequently not permit or require removal of old coatings prior to repainting. However, all surface contaminants such as oil, grease, loose paint, mill scale, dirt, foreign matter, rust, mold, mildew, efflorescence, and sealers must be removed to assure sound bonding to the tightly adhering old paint. Glossy surfaces of old paint films must be clean and dulled, and/or sanded before repainting. Thorough washing with an abrasive cleaner will clean and dull in one operation, or wash thoroughly and dull by sanding. Spot prime any bare areas with appropriate primer. Adhesion to existing glossy surfaces may require bonding primers.

Adhesion Testing: Check for adhesion by applying a test patch of the recommended coating system, covering at least 2 to 3 square feet. Allow to dry one week before testing adhesion per ASTM D3359. If the coating system adhesion fails, report findings to Architect. Provide bonding primers where adhesion testing has failed or is in question.

Existing Stained Wood:

Wood must dry and cleaned of dirt, grease, wax, polish, and marks. Old finishes in poor condition should be completely removed and the surface treated as a new surface. Sand wood to a smooth surface with 100-120 grit paper. Remove sanding dust with a vacuum or tack cloth. Avoid sanding wood that has only stain on it, sanding will remove some of the stain creating an uneven appearance. Sand down bare spots and scratches, and stain to match adjacent color. Very lightly scuff sand between finish coats, 180 grit paper or finer, removing any raised graining. Perform adhesion testing, identifying any presence of any sanding sealer, which can prevent bonding and cause peeling.

SURFACE RESTORATIONS

Existing surfaces requiring restoration, including but not limited to existing steel door frames or existing window frame surfaces, require total surface cleaning complete, down to bare sound metal, in accordance with the applicable SSPC method required, and then surfaces immediately primed with applicable primer coats in DFT thicknesses required, prior to further ensuing work sequences; i.e. finish paint coats, re-glazings, frame preparations for hardware.

In addition to the Part 3 SURFACE PREPARATIONS specified, removal of all rust from existing surfaces may require sand blasting. Adhere to sandblasting requirements complying with 02070 Selective Demolition.

Once metal sections have been cleaned of all corrosion, small holes, depressions, and uneven areas resulting from rusting are to be filled with a patching material and sanded smooth to eliminate pockets where water can accumulate, and primed coated. Patching material shall be of high content steel fibers in an epoxy binder, similar to industrial steel repair or auto body patching materials

LEAD-BASED PAINT RENOVATION, REPAIR, AND PAINTING:

Applicators who perform painting renovations in housing or child occupied facilities built before 1978 must be certified by the Health Hazards Control Unit (HHCU). All work shall comply with requirements as published by the EPA Lead-Based Paint Renovation, Repair and Painting Rule in the Code of Federal Regulations.

Samples: For determining whether components are free of lead-based paint, certified applicators may collect paint chip samples and submit samples to a laboratory recognized by NLLAP for analysis. Required paint chip samples documentation shall be prepared and maintained by the certified applicator for three years.

MATERIALS PREPARATION:

Mix and prepare painting materials in accordance with manufacturer's directions.

Stir materials before application to produce a mixture of uniform density, and stir as required during application. Do not stir surface film into material. Remove film and, if necessary, strain material before using.

APPLICATION:

General: Apply paint in accordance with manufacturer's directions. Use applicators and techniques best suited for substrate and type of material being applied.

Apply additional coats when undercoats, stains or other conditions show through final coat of paint, until paint film is of uniform finish, color and appearance, and complete hide. Give special attention to insure that surfaces, including edges, corners, crevices, welds, and exposed fasteners receive a dry film thickness equivalent to that of flat surfaces.

Special Food Service Area Wall Application: Roll-in two coats of masonry block filler coating in Food Service areas as necessary to completely fill all pits and pores prior to application of top coats. Final finished topcoat in Food Service areas to be free of all pits and pores, with a smooth completely washable surface. Apply additional coats when final coat of paint does not uniformly fill all pits and pores. Provide all work described as necessary to obtain an on-site approval by local Health Department.

Finish exterior doors on tops, bottoms and side edges same as exterior faces, unless otherwise indicated.

Sand lightly between each succeeding enamel or varnish coat.

Omit first coat (primer) on metal surfaces which have been shop-primed and touch-up painted, unless otherwise indicated.

Mechanical and Electrical Work: Painting of mechanical and electrical work is limited to those items exposed in occupied spaces.

Completed Work: Match approved samples for color, texture and coverage. Remove, refinish or repaint work not in compliance with specified requirements.

CLEAN-UP AND PROTECTION:

Clean-Up: During progress of work, remove from site discarded paint materials, rubbish, cans and rags at end of each work day.

Upon completion of painting work, clean window glass and other paint-spattered surfaces. Remove spattered paint by proper methods of washing and scraping, using care not to scratch or otherwise damage finished surfaces.

Protection: Protect work of other trades, whether to be painted or not, against damage by painting and finishing work. Correct any damage by cleaning, repairing or replacing, and repainting, as acceptable to Architect.

Provide "Wet Paint" signs as required to protect newly-painted finishes. Remove temporary protective wrappings provided by others by protection of their work, after completion of painting operations.

At the completion of work of other trades, touch-up and restore all damaged or defaced painted surfaces.

EXTRA STOCK:

Furnish extra paint in manufacturer's sealed shipping containers. Provide one gallon for each type and color of paint applied in the project. Containers shall only be opened by the painter manufacturer/supplier to formulate required colors/mixes. These extra materials shall not be opened or used by the Contractor without written permission from the Owner. Place a label, protected by clear plastic on the lid of each container with the following typewritten information:

1. Paint Manufacturer
2. Product name and number
3. Mixing and color formulation
4. Painting contractor
5. Date that the paint container is put in the Owner's inventory
6. Room or area number where the paint applied was used

END OF SECTION

PRELATED DOCUMENTS:

Drawings and general provisions of Contract, including General and Supplementary Conditions and Division-1 Specification sections, apply to work of this section.

ART 1: GENERAL

DESCRIPTION OF WORK:

Extent of chalkboards, markerboards, and tackboards is shown on drawings.

Types of chalkboards, markerboards, and tackboards specified in this section include the following:

- Liquid Markerboards
- Vinyl Faced Natural Cork Tackboards
- Corridor Natural Cork Tackstrips

QUALITY ASSURANCE:

Manufacturer: Unless otherwise acceptable to Architect, furnish all markerboards and tackboards by one manufacturer for entire project.

Surface Burning Characteristics: Provide tackboard surfaces which are identical in composition to those with surface burning characteristics indicated below, as determined by testing in compliance with ASTM E 84. Use only tackboards which are labeled and listed by a testing and inspection agency acceptable to authorities having jurisdiction.

Flame Spread: Not more than 25

Smoke Developed: Not more than 25

SUBMITTALS:

Product Data: Submit manufacturer's technical data and installation instructions for each material and component part, including data substantiating that materials comply with requirements.

Samples: Submit full range of color samples for each type of chalkboard, tackboard, trim and accessories required. Provide 12" square samples of sheet materials and 12" lengths of trim members for color verification after selections have been made.

Shop Drawings: Submit for each type of markerboard and tackboard. Include sections of typical trim members and dimensioned elevations. Show anchors, grounds, reinforcement, accessories, and installation details.

SPECIALTY PROJECT WARRANTY:

Warranty on Porcelain Enamel Markerboards: Provide written warranty, signed by manufacturer, agreeing to replace, within the lifetime of the original installation, porcelain enamel markerboards which do not retain original writing and erasing qualities, defined to include surfaces which become slick and shiny, or exhibit crazing, cracking, or flaking; provide manufacturer's instructions for handling, installing, protecting and maintaining markerboards have been adhered to during the warranty period. Replacement is limited to material replacement only and does not include labor for removal and reinstallation.

Warranty Period: Life of original installation

PART 2: PRODUCTS

ACCEPTABLE MANUFACTURERS:

Available Manufacturers: Subject to compliance with requirements, manufacturers offering products which may be incorporated in the work include the following:

Manufacturers Markerboards and Tackboards:

- Claridge Products and Equipment
- PolyVision
- Greensteel, Inc.

MATERIALS:

Markerboards:

24 gauge porcelain enamel steel with 3.5 - 4.5 mil surface deposition, fired onto steel sheet at no less than 1500 degrees Fahrenheit. Reflectance no more than 20% and no less than 15%. Core to be 1/2" particleboard with aluminum moisture retardant backer sheet. Shall accept dry erase felt tip marker, grease pencil, ball point pens, pencils, and crayons, and can be cleaned with a damp cloth. Permanent marker may be removed with a mild solvent. Equivalent to Claridge "LCS24 Markerboard" – Color No. 32 LCS White

Vinyl Faced Tackboards:

Self-healing, mildew resistant textured vinyl over single layer 1/4" thick, seamless compressed cork sheet, face sanded for natural finish, complying with MS MIL-C15116, laminated to 1/4" hardboard.

Corridor Natural Cork Tack Strips:

Provide (2) 12 ft. long x 2" aluminum/cork tackstrips outside of classrooms on corridor walls. Total of 59 classrooms. Equivalent to Claridge Map and Display Rail; Model 74EZ, aluminum rail 2" wide with 1 5/8" natural cork insert. Mount as indicated by Architect.

TRIM AND ACCESSORIES:

General: Fabricate frames and trim of not less than 0.062" thick aluminum alloy, size and shape as indicated, to suit type of installation. Provide straight, single-length units wherever possible and keep joints to minimum. Miter corners to neat, hairline closure.

Markerboard Trim: Claridge Products "Series I", 1 1/2" wide frame trim, or equivalent.

Tackboard Trim: Claridge Products, 5/8" trim, or equivalent.

Retrofit Closure Trims: Claridge Products extruded aluminum closure trims, size as required to suit condition.

Aluminum Finish: Furnish exposed aluminum trim, accessories and fasteners with the following finish:

Clear Anodized Finish: Manufacturer's standard satin anodized finish with clear anodic coating complying with AIA requirements for Class II Architectural Coating (AA-A31).

Field-Applied Trim: Provide one of the following types:

- Slip-on trim, to eliminate grounds.
- Screw-on trim, with Phillips flat-head screws.

Chalkboards and Markerboards: Furnish continuous aluminum chalk troughs for each chalkboard, unless otherwise indicated, as follows: Solid extrusion box profile, manufacturer's standard ribbed section, with cast aluminum end caps.

Map Rail: Furnish map rail at top of each unit, unless otherwise indicated, with the following accessories for each map rail:

- Display Rail: Continuous cork approximately 2" wide, integral with map rail.
- End Stops: One at each end of map rails.
- Map Hooks: 2 for each 4' of map rail or fraction thereof.
- Flag holder: One for each room furnished.

FABRICATION:

Assembly: Provide factory-assembled chalkboard and tackboard units unless field-assembled units indicated.

Make joints only where total length exceeds maximum manufactured length. Fabricate with minimum number of joints, balanced around center of board, as acceptable to Architect.

Provide manufacturer's standard vertical joint system between abutting sections of chalkboard.

Provide mullion trim at joints between chalkboard and tackboard.

PART 3: EXECUTION

INSTALLATION:

Install units in locations and mounting heights as shown on drawings and in accordance with manufacturer's instructions, keeping perimeter lines straight, plumb, and level. Provide all grounds, clips, backing materials, adhesives, brackets, anchors, trim, and accessories for complete installation.

ADJUST AND CLEAN:

Verify accessories required for each unit are properly installed.

Clean units in accordance with manufacturer's instructions, breaking in only as recommended.

END OF SECTION

RELATED DOCUMENTS:

Drawings and general provisions of Contract, including General and Supplementary Conditions and Division-1 Specification sections, apply to work of this section.

PART 1: GENERAL

DESCRIPTION OF WORK:

Work of this Section shall be to provide Flagpoles as shown on Drawings and specified in this Section.

INDUSTRY STANDARDS:

For listing of names of industry standard agencies mentioned by abbreviation in this Section, refer to Section 01068.

QUALITY ASSURANCE:

Manufacturers:

Standard: For purpose of designating type and quality for work under this Section, Drawings and Specifications are based on products fabricated by American Flagpole. Other Manufacturers who can furnish similar products or systems of same materials specified, will also be acceptable.

SUBMITTALS:

Manufacturer's Data: Submit for approval three (3) copies of folder containing complete Manufacturer's data and installation procedures for all products to be used in work of this Section.

Shop Drawings: Submit Shop Drawings in compliance with GENERAL CONDITIONS. These drawings shall be coordinated with adjacent work.

PRODUCT HANDLING:

Working Areas: Provide suitable areas for storage of materials and equipment.

Delivery: Deliver products to site in original sealed containers or packages bearing Manufacturer's name and brand designation.

PART 2: PRODUCTS

Mast: Shall be 6063T6 aluminum alloy, clear anodized, seamless single-piece, designed to withstand 120 m.p.h. wind. Mast shall be tapered, with an exposed height of 35 feet for single poles and, where groups of three are indicated, 35' for center pole and 30' for flanking poles. Minimum butt diameter shall be 6".

Fittings: Finial shall be manufacturer standard ball. Truck shall be revolving double 2 3/8" dia. sheaves, aluminum. Halyards to be #10 multi-filament braided polypropylene with two bronze snap hooks for each. Cleats: 9" aluminum.

Mounting Hardware: Provide aluminum flash collar; 16 gauge corrugated galvanized steel foundation sleeve.

PART 3: EXECUTION

INSTALLATION:

Flagpole shall be installed in concrete according to manufacturer's approved shop drawings, by an accredited crew experienced in the handling, assembly, and placement of flagpoles.

END OF SECTION

RELATED DOCUMENTS:

Drawings and general provisions of Contract, including General and Supplementary Conditions and Division-1 Specification sections, apply to work of this section.

PART 1: GENERAL

DESCRIPTION OF WORK:

Work of this Section shall include but is not limited to: provide and install all building interior and building exterior signs, exterior building letters, digital school signs, dedication plaques and to provide for the purchase of building equipment as determined by the Owner. Signs, plaque, shelving and equipment indicated to be purchased and installed with the allowance specified in 01056 Allowances, to include tax and freight, but not to include labor or installation, except as specifically stated below. Signs and equipment shall be installed by the Contractor in accordance with the manufacturer's recommendations.

Equipment Platform egress ladder signage is not part of this allowance. Construction of masonry pedestal base for a school sign is not a part of this allowance. Project sign, site directional and parking signs are not part of this allowance.

INDUSTRY STANDARDS:

For listing of names of industry standard agencies mentioned by abbreviation in this Section, refer to Section 01068.

SUBMITTALS:

Manufacturer's Data: Submit for approval three (3) copies of folder containing complete Manufacturer's data and installation procedures for all products to be used in work of this Section.

Shop Drawings: Submit Shop Drawings in compliance with GENERAL CONDITIONS. These drawings shall be coordinated with adjacent work.

PART 2: MATERIALS

PRODUCTS: (final total list of equipment to be final approved by the Owner)

Interior Signage: Interior signage panels shall be solid one-piece 1/8" thick thermoformed acrylic materials, raised ADA tactile copy, graphics and grade II braille, attached to walls with (4) screws each, at ADA compliant height. Provide Lucent Series one-piece thermoformed acrylic by Best Sign Systems or equivalent by Mohawk Signs, with subsurface paint and suede texture finish. Mount with (4) recessed countersunk flat head screws.

Dedication Plaque (installed): Cast aluminum.

Digital School Sign: Design to be determined by Architect.

Wood Storage Shelving: Pre-Manufactured Wood Storage shelving for custodial and storage spaces, per Section 10445 Storage Shelving.

Art Room Kiln (installed): Installed in Kiln Room, provide: KilnMaster KM Series Scutt kiln – Model KM1227 3PK 208, exhaust downdraft vent kit – Skutt Model Envirovent 2, with EnviroLink electrical

switching auto controls module, and furniture accessories kit – Skutt Model 1227-3. Install EnviroLink control wiring in accordance with manufacturer's installation instructions.

PART 3: EXECUTION

PRODUCT HANDLING:

Working Areas: Provide suitable areas for storage of materials and equipment.

Delivery: Deliver products to site in original sealed containers or packages bearing Manufacturer's name and brand designation.

INSPECTION

Examine all surfaces to which products are scheduled to be installed. If unsatisfactory conditions exist, report to General Contractor and do not proceed with work until conditions have been satisfactorily corrected.

INSTALLATION:

Install signs in accordance with Manufacturer's printed instructions and Shop Drawings, with four (4) screws, approved by Architect. Signs to be located with leading edge 10" from pull edge of door, center 60" above floor.

All installations shall be performed by capable workmen under direction of foreman fully qualified by experience in each respective field of installation work.

Install all equipment per processed product submittals and written manufacturer's installation instructions.

END OF SECTION

RELATED DOCUMENTS:

The general provisions of the Contract, including General and Supplementary Conditions, General Requirements, and Division 1 specifications, that apply to the work specified in this section.

PART 1: GENERAL

DESCRIPTION OF WORK:

Work of this Section shall be to provide and install all pre-manufactured wood storage shelving, and other items not specifically described, as indicated on Drawings. Purchase and install shelving with Sections 01056 and 10440 Allowances

INDUSTRY STANDARDS:

For listing of names of industry standard agencies mentioned by abbreviation in this Section, refer to Section 01068.

SUBMITTALS:

Manufacturer's Product Data: Submit for approval three (3) copies of folder containing complete Manufacturer's detailed product data and installation procedures for storage units to be used in work of this Section. Indicate unit construction including finishes.

Shop Drawings: Submit Shop Drawings in compliance with GENERAL CONDITIONS. These drawings shall be coordinated with adjacent work. Indicate locations, materials, thickness of parts, location and type of hardware, methods of assembly and jointing, and finishes.

Take measurements at the site for space where each item is to be placed.

PART 2: MATERIALS

PRODUCTS:

Pre-Manufactured Wood Storage Shelving:

Excalibur Shelving Systems by Palmetto Shelving Systems, Inc. (803) 781-9955; 84" high heavy duty wood shelving units (installed) – 16", 18" and 24" widths, lengths as indicated on Drawings, 750 lb. load capacity.

- A. Uprights: Hemlock or Douglas Fir (1-5/8" x 1-5/8")
 - 1. 3/8" x 5/8" deep plow entire length of stiles to receive shelf end channels with 3/16" drilled holes on 1" centers. Uprights to be sufficient height for shelving to be 7"-0" high
 - 2. Stiles are to be locked together with three or more cross members mortised glued and pinned into the stiles
 - 3. All components are to be machined smooth with all outside corners eased.

- A. Shelves: Not less than 3/4" pine shelf materials are to be machined to accept roll formed steel end channels shaped to fit over each end of the shelf and to rest on the shelf support pins. Finger joints are not acceptable.
 - 1. Seven (7) shelves per section

- C. Shelf Support Pins: Non rusting alloy, 3/16" diameter x 1-1/4" long, 5/16" diameter head.
- D. "X" Braces: Two 18 gauge galvanized 3/4" steel straps with holes punched at each end. Rivet straps at centers. One "X" brace required every three (3) sections.
- E. Back Panels: All back-to-back units for book storage to have 1/8" Abitibi S2S tempered hardboard back panels.
- F. Kickboard: Provide a 4" pine kickboard for each unit.
- F. Finish: Factory seal & lacquer (site finish is not acceptable)
- G. Shelving shall be manufactured for wall-to-wall fit, as indicated on Drawings. Gaps in excess of 2" are not accepted.
- H. Where dead corners are indicated on Drawings, solid end panels and closure panels will be required. Brace anchor all wall units.
- I. Shelves shall not exceed 36" in length, and no less than 3/4" thick.

DELIVERY, STORAGE AND PRODUCT HANDLING:

Working Areas: Provide suitable areas for storage of materials and equipment.

Delivery: Deliver products to site in original sealed containers or packages bearing Manufacturer's name and brand designation. Deliver storage units only after building is enclosed and wet operations in building are completed.

Protect finished surfaces from soiling and damage during handling and installation.

PART 3: EXECUTION

INSPECTION

Examine all surfaces to which products are scheduled to be installed. If unsatisfactory conditions exist, report to General Contractor and do not proceed with work until conditions have been satisfactorily corrected.

Field measure at site for space where each item is to be placed.

INSTALLATION:

Install shelving in accordance with Manufacturer's current printed instructions and Shop Drawings, approved by Architect.

All installations shall be performed by capable workmen under direction of foreman fully qualified by experience in each respective field of installation work.

Install all shelving per processed product submittals and current written manufacturer's installation instructions. Brace anchor all wall units.

END OF SECTION

RELATED DOCUMENTS:

Drawings and general provisions of Contract, including General and Supplementary Conditions and Division-1 Specification sections, apply to work of this section.

PART 1 - GENERAL

DESCRIPTION OF WORK

- A. Extent of metal lockers is shown on Drawings.
- B. Types of products in this section include the following:
 - 1. Kitchen lockers.
 - a. Single-tier lockers.
 - b. Accessories shall include:
 - 1) Metal filler panels.
 - 2) 20 gauge (min.) sloping tops
- C. Provide necessary quantity of Accessible lockers per the local accessibility codes having jurisdiction.
- D. Concrete base for lockers is specified in Division 3.
- E. And additional material not specifically mentioned but necessary to provide a completed installation shall also be included.

QUALITY ASSURANCE

- A. Uniformity: Provide each type of metal locker as produced by a single manufacturer, including necessary mounting accessories, fittings, and fastenings for a complete assembly.

SUBMITTALS

- A. Product Data: Submit manufacturer's technical data and installation instructions for metal locker units.
- B. Product Data: Submit manufacturer's technical data, product data, surface preparation and paint application instructions for refurbishing existing metal locker units.
- C. Samples: Submit color samples on squares of same metal to be used for fabrications of lockers.
- D. Shop Drawings: Submit shop drawings for metal lockers, verifying dimensions affecting locker installations. Show lockers in detail, method on installation, fillers, trim, base, and accessories. Include locker numbering sequence information. Shop drawings should clearly indicate the material being supplied and showing all gauges according to the enclosed specifications.
- E. Sample Lockers: Build mock-up sample locker of each type required, present sample for review and approval by Architect and Owner prior to fabrication.

JOB CONDITIONS

- A. Do not deliver metal lockers until building is enclosed and ready for locker installation. Protect from damage during delivery, handling, storage, and installation.

PART 2 - PRODUCTS

- A. Acceptable Manufacturers
 - 1. Manufacturer: subject to compliance with specified requirements, provide products of one of the following:
 - a. De Bourgh Mfg. Co. – Corridor Locker with "Sentry III" single point latching.
 - b. GSS (General Storage Systems) - Decor Tri-Lock Eclipse.
 - c. List Industries, Inc, - Superior Heavy Duty Corridor Premier
 - d. Other interested suppliers must have prior written approval.

B. Materials:

1. Size:
 - a. Kitchen: Single tier (60"), 12" wide, 12" depth.
2. Sheet Steel: Mild cold-rolled and leveled steel, free from buckle, scale, and surface imperfections.
3. Expanded Metal: $\frac{3}{4}$ " mesh flattened carbon steel, 13 gage minimum.
4. Fasteners: Cadmium, zinc, or nickel plated steel: exposed bolts heads, slotless type; self-locking nuts or locker washers for nuts on moving parts.
5. Equipment: Hooks and hang rods of cadmium-plated or zinc-plated steel or cast aluminum.
6. Kitchen locker bodies shall be fabricated from 24 gauge pre-painted steel. Sides to have stiffening ribs and backs flanged, formed and factory punched to provide necessary assembly holes. Top, bottoms and shelves shall be flanged on all four sides with a channel formation at the front of the shelves. Provide 20 gauge sloped tops all lockers.
7. Kitchen locker doors shall be all welded construction consisting of a 16 gauge outer panel and a 24 gauge full door size inner panel welded together to form a rigid box construction. The door shall close on a 16 gauge frame member with closure strike the full height of the door and shall fit flush with the outside of the frame. No parts shall be proud of frame.
8. All lockers shall be padlock latching with single point latch mechanism.
9. Frames shall be welded together from specially formed channel sections of prime cold rolled steel.
10. Provide two rubber door grommets on the lock side of the frame.
11. Hinges: Heavy-duty, not less than 0.050" thick steel, full-loop, tight pin, piano type hinge. Weld to inside of frame and secure to door completely concealed and tamperproof when door is closed.
12. Provide recessed number plates. Plates shall be numbered as directed by the Architect. Plates shall be mechanically fastened.
13. Single-Tier Locker shall have a shelf located approximately 14" below the top. Single-Tier and Double-Tier locker compartment shall have 3 zinc-plated round tipped metal coat hooks, attached to locker body.
14. Finish: all cold rolled surfaces shall be thoroughly cleaned before painting with a phosphoric, acid based cleaner. The parts shall be electrostatically sprayed with one coat of high-grade alkyd paint enamel and baked with the proper temperature/time relationship to ensure a tough, durable finish.
15. Colors: selected from Manufacturer's standard color choices. .
16. Acoustical Treatment: Provide construction treatment designed to significantly reduce noise of locker operation, including protected sound-absorbing material within door, nylon or plastic coatings on operating components to prevent metal-to-metal contact, and latching mechanism designed to operate without rattling.

C. FABRICATION, GENERAL

1. Construction: Fabricate lockers square, rigid, and without warp, with metal faces flat and free of dents or distortion. Make all exposed metal edges safe to touch. Weld frame members together to form rigid, one-piece structure. Weld, bolt, or rivet other joints and connections as standard with manufacturer. Grind exposed welds flush. Do not expose bolts or rivet heads on fronts of locker doors or frames.

D. WARRANTY

1. Provide warranty guaranteeing the work against product and workmanship defects for one year. Guarantee covers paint cracking, flaking, peeling, blistering and chipping not due to normal wear and tear.

END OF SECTION

RELATED DOCUMENTS:

Drawings and general provisions of Contract, including General and Supplementary Conditions and Division-1 Specification sections, apply to work of this section.

PART 1: GENERAL

DESCRIPTION OF WORK:

Provide fire extinguisher cabinets and extinguishers as shown on drawings and specified herein. Provide cabinets for all extinguishers except as otherwise noted.

QUALITY ASSURANCE:

Manufacturers: Fire extinguisher cabinets and extinguishers of following manufacturers, which meet all requirements of these Specifications and approved equal products by other manufacturers, will be acceptable for use on this Project:

- Norris Industries
- J. L. Industries
- Larsen's Mfg. Co.

SUBMITTALS:

Shop Drawings: Submit to Architect in quadruplicate Shop Drawings for approval of all items specified herein in accordance with General Conditions.

PART 2: PRODUCTS

Fire Extinguisher cabinets shall be "Clear Vu Series" model 1536G25, semi-recessed, with full clear acrylic bubble door and SAF-T-LOK feature, Fire Rated at fire-rated walls, white powder coated steel tub, stainless steel door and trim finish, as manufactured by JL Industries or approved equal. Cabinet shall accommodate and include a 10 pound, Class ABC extinguisher unless otherwise noted.

Furnish 10 pound, Class ABC extinguishers with wall mount bracket in each Custodian Room, equivalent to Cosmic 10E extinguisher.

Furnish 10 pound, Class ABC extinguishers with wall mount bracket on each Equipment Platform where indicated.

Furnish 1.8 gallon Class K extinguishers in cabinets in Kitchen, equivalent to Saturn 15 extinguisher in model 2536G25 cabinet.

Furnish one (1) 5 pound, Halon extinguisher in each Computer Lab and/or each Electronics Lab, equivalent to Mercury 5 extinguisher.

Furnish one (1) each 10 pound, Class BC extinguishers with wall mount bracket in Electrical and Boiler/Mechanical Rooms, no cabinet, equivalent to Galaxy 10 extinguisher.

PART 3: EXECUTION

INSTALLATION:

Install fire extinguisher cabinets in accordance with Manufacturer's written instructions, Catalog Cuts approved by Architect, and location pre-approved by local fire official.

END OF SECTION

RELATED DOCUMENTS:

The general provisions of the Contract, including General and Supplementary Conditions, and General Requirements, and Division 1 specifications that apply to the work specified in this Section.

PART 1 GENERAL

1.1 SUMMARY

- A. Section includes: Pre-engineered and pre-finished extruded aluminum walkway covers, canopies, and sun shade awnings.
- B. Related Sections:
 - 1. 03100-Concrete Forms and Accessories
 - 2. 03300-Cast-in-Place Concrete

1.2 SYSTEM DESCRIPTION

- A. Design Requirements:
 - 1. Columns, beams, decking with flat soffits and trim shall be aluminum extrusions. Structural framing shall consist of heli-arc welded, one-piece rigid bents and bolt connected members] with interlocking deck sections secured by screws.
 - 2. Walkway canopies shall be self-draining from decks through bents and down column downspouts to discharge points at ground level as shown on Drawings.
 - 3. Wall supported sun shade awnings shall be self-draining from deck out a built-in outer corner side discharge scupper.
 - 4. Building Code: IBC and North Carolina Building code current editions.
 - 5. Design Loads:
 - a. Comply with Building Code for site location.
 - b. Collateral Loads: Additional loads imposed by other materials or systems identified in contract documents.
 - 4. Structural Design: Prepare complete structural design calculations and detailed design for canopy members and foundations. Provide to Architect within 45 days of Contract Award to General Contractor and coordinate structural work as required with Architect.

1.3 SUBMITTALS

- A. Reference Section 01330-Submittal Procedures; submit following items:
 - 1. Product data.
 - 2. Shop Drawings: Layout and erection drawings showing roof framing, deck panels, cross sections and trim details clearly indicating proper assembly, with foundation design, with Sealed Structural Design Calculations.
 - 3. Samples: Color selection samples consisting of actual coating material or anodizing process on aluminum extrusions.
 - 4. North Carolina regulatory review approval: Structural design and calculations sealed by a structural engineer registered to practice in the state of North Carolina.
 - 5. Quality Assurance/Control Submittals:
 - a. Qualifications: Letter certifying manufacturer's required qualifications.
 - b. Structural Design: Calculations sealed by a structural engineer registered to practice in the state of North Carolina.
 - c. Complete design and detail drawings for canopy and foundations.
 - d. Manufacturer's Installation Instructions.

1.4 QUALITY ASSURANCE

- A. Overall Standards: Structural engineering design documents shall be certified and sealed by a structural engineer registered to practice in the state of North Carolina.
- B. Qualifications:
 - 1. Manufacturer Qualifications: Minimum ten years experience in producing covers/canopies with welded bents and of the type specified.
 - 2. Installer Qualifications: Minimum five years experience in erecting covers/canopies of the type specified. Installations shall be in accordance with manufacturer's shop drawings.

1.5 DELIVERY STORAGE AND HANDLING

- A. Reference Section 01660-Product Storage and Handling Requirements.
- B. Follow manufacturer's instructions.

PART 2 PRODUCTS

2.1 MANUFACTURERS

- A. Manufacturer / Basis of Design: Mapes Company (Super Lumideck with Flat Soffit system for canopies)

Equivalent products from the following manufacturers are acceptable. Reference AIA A701 Instructions To Bidders - Product Substitution Procedures.

Perfection Architectural Systems, Inc.
E.L. Burns Co., Inc.
Superior Metal Products
Peachtree Protective Covers

2.2 MATERIALS

- A. Aluminum Extrusions: 6063 alloy, T-6 temper.
- B. Grout: 1 part portland cement, 3 parts masonry sand; 2,000 psi (13.8 MPa) compressive strength.
- C. Foam Block-Outs: Rigid foam blocks sized as required for column embedment depth and shape.

2.3 COMPONENTS

- A. Columns:
 - 1. Radius-cornered aluminum tubular extrusions [of size shown on Drawings] [as required by structural engineering design].
 - 2. Grout Key: Provide two 1 ½ inch (38 mm) diameter holes in column base, one each in opposite sides.
 - 3. Provide clear acrylic protection coat on surfaces in contact with grout.
- B. Beams: Open top aluminum tubular extrusions as required by structural engineering design.
- C. Flat Soffit Deck: Rigid-Roll-Lock extruded aluminum, 2 ¾" extruded .018" self-flashing, interlocking sections with flat soffit panels, as required by structural engineering design.
 - 1. Provide welded endplate water dams where sections terminate at other than drainage channels.

- D. Hanger Rods: Powder coated to match canopy awning. Sized and attached as shown in drawings and as required by structural engineering design.
- E. Fascia: Provide manufacturer's standard extruded aluminum fascia and gutter sections as shown on Drawings and as required to complete the installation resulting in a neat finished appearance.
- F. Flashing: Aluminum sheet, thickness as recommended by manufacturer for specific condition.
- G. Conduit Cover: Extruded aluminum pre-finished continuous cap. Anchored down to the roof deck upper section to provide a continuous watertight enclosure for routing of electrical conduits and concealed weather protected roof deck penetrations.

2.4 ACCESSORIES

- A. Fasteners:
 - 1. Deck Screws: No. 14 x 1 inch (25 mm), self tapping, Type 18-8 stainless steel with neoprene washer.
 - 2. Trim Screws: No. 10 x ½ inch (13 mm), self tapping, Type 18-8 stainless steel.

2.5 FABRICATION

- A. Shop Assembly: Fabricate cross beams and columns for field assembled bolted connections.

2.6 FINISH

- A. Finish on all exposed components shall be a Fluoropolymer Coating: 70 percent PVDF resin based fluoropolymer, AA-C-12C-42R-1, equivalent to two-coat Kynar, in compliance with AAMA 2605.
- B. Color: Architect will select colors from full range of manufacturer's two-coat Kynar fluoropolymer colors.

PART 3 EXECUTION

3.1 EXAMINATION

- A. Examine footings in which bents will be set and building surfaces to which canopy will connect. Verify footing locations, details and elevations comply with shop drawings.
- B. Coordinate with responsible entity to perform corrective work on unsatisfactory footings or surfaces.
- C. Commencement of work by installer is acceptance of existing conditions.

3.2 ERECTION

- A. Erect canopy in accordance with manufacturer's installation instructions.
- B. Set bents plumb, straight and true to line, adequately braced to maintain position until grout has cured.

3.3 CLEANING

- A. Clean surfaces soiled by work as recommended by manufacturer.
- B. Remove surplus materials and debris from the site.

3.4 PROTECTION

- A. Protect finished aluminum surfaces from damage due to subsequent operations through final acceptance by the Owner.

END OF SECTION

PART 1: GENERAL

1.01 RELATED DOCUMENTS:

- A. Drawings and general provisions of the Contract, including General and Supplementary Conditions and Division 1 Specification Sections, apply to this Section.

1.02 SUMMARY:

- A. This section shall include the furnishing of all tools, equipment, and labor necessary for the following systems:
 - 1. Manually operated, hinged paired panels, operable wall system – MULTIPURPOSE 132, RESOURCE 203, RESOURCE 403.
- B. Manufacturer shall furnish operable walls complete with hardware, tracks, hanger rods, stack jamb, soffits, soffit guide rails and all necessary mechanisms to provide complete operation.

1.03 WORK BY OTHERS:

- A. All supporting structures and members at head and jambs; track enclosures including sound insulation, sound baffles, trim and finishing of same.
- B. Any preparing of and/or punching of the support structures.
- C. Preparation of the opening shall be by the General Contractor. Any changes to the project site condition, contrary to the reviewed shop drawings, shall be brought to the attention of the Architect.

1.04 SYSTEM PERFORMANCE REQUIREMENTS:

- A. Acoustical Performance: Operable panel systems shall have been tested by a qualified independent testing agency in a full scale opening (14 feet by 9 feet) for laboratory sound transmission loss performance according to ASTM E90-81, determined by ASTM E413 and shall be rated:
 - 1. Operable Partition – not less than STC 52
- B. Field sound performance shall have been tested on an actual field installation by an independent certified acoustical consultant in accordance with ASTM E336 and shall have achieved no less than a 42 NIC. A written test report by the acoustical consultant shall be furnished to the Architect upon request.

1.05 SUBMITTALS:

- A. General: Submit the following according to the Conditions of the Contract and Division 1 Specification Sections.

Product Data on physical characteristics, durability and surface burning characteristics for each type of operable panel partitions system specified.

Shop Drawings showing location and extent of all operable panel partitions systems. Include plans, elevations, method of attachment to building structure, conditions at openings with wall thickness and materials, typical and special details of construction, location and installation requirements for hardware and operators, and all accessory items.

Template drawings prepared by the operable partition manufacturer showing location of items supported by or anchored into the building structure and wherever attachment occurs.

- B. Samples for initial selection purposes in the form of manufacturers color charts showing a full range of colors, textures and patterns available for each type of panel finish indicated on the shop drawings.
- C. Acoustical test report certificates indicating that the operable panel partition systems have been tested by an independent acoustical testing agency and comply with the specified minimum STC ratings.

1.06 QUALITY ASSURANCE:

- A. Installer Qualifications: Engage an experienced Installer who is certified in writing by the operable panel partition manufacturer as qualified to install the manufacturer's partition systems specified herein.
- B. Surface Burning Characteristics: Provide panel finish faced with the following surface burning characteristics as determined by testing identical products per ASTM E84 by UL or other testing and inspecting agencies acceptable to authorities having jurisdiction.

Flame Spread: 25 or less

Smoke Developed: 450 or less

1.07 DELIVERY, STORAGE, AND HANDLING:

- A. Deliver materials to project site in original factory wrappings and containers.
- B. Store panels on edge, blocked off ground to prevent sagging and warping, in original undamaged packages. Store panels in an enclosed, climatized environment. Panels shall be protected from weather, moisture, soiling, extreme temperatures and humidity.
- C. Comply with instructions and recommendations of manufacturer for special delivery, storage, and handling requirements.

1:08 WARRANTY:

Partitions system shall be guaranteed against defects in materials and workmanship for three years. Suspension system shall be guaranteed against defects in materials and workmanship for five years.

PART 2: PRODUCTS

2.01 ACCEPTABLE MANUFACTURERS:

The operable panel partition systems are subject to complete and total compliance with this specification, the following manufacturers are acceptable:

- A. Hinged Panel System:
 - 1. Kwik-Wall "Series Model 3030, Manually Operated, Hinged Paired Panels".
 - 2. Modernfold. Acousti-Seal Encore Paired Panel System
 - 3. Equivalent products from Hufcor.

2.02: OPERABLE PANEL PARTITION SYSTEMS:

- A. Operable Walls shall be installed by an authorized representative of the manufacturer in openings prepared by others to the approved operable wall product requirements.
- B. PANELS shall be nominal 4" thick and nominally 49" wide. Steel panel faces shall be welded to minimum 14-gauge frames. Panels shall have appropriate internal insulation to achieve specified STC. The tops of the panels shall be reinforced to support suspension components. The vertical edges of the panels shall not require trim thus minimizing the appearance of the vertical joining of the panels.
- C. Panel Weights: Maximum panel weight per square foot shall be 12 pounds per square foot.
- D. Operation shall consist of a series of manually operated flat panels, top supported. Top and bottom seals shall be as specified in Part 2.07.

2.03 OPERABLE PARTITION SYSTEM CONFIGURATION:

- A. Operable panel partition system shall have all of the features and operational characteristics specified and noted herein, end-of-wall stack operation. Panel configuration shall be comprised of panels hinged in pairs and end-of-wall stacking. Final closure shall be affected by expandable panels.

2.04 HARDWARE:

- A. Manufacturer's standard finished to match exposed hardware on the partitions.
- B. Panels that are hinged together shall be hinged with manufacturer's standard butt-type hinges.
- C. Single Pass Doors, where indicated on Drawings, shall be nominally 3'-0" wide by 7'-0" high. Doors shall be manufactured of the same materials and thickness as the panels and be equipped with butt-type hinges and positive latches with drop cup and ring pulls.

2.05 SUSPENSION SYSTEMS:

- A. Panels shall be supported by trolley assemblies of radial type steel or carbon fiber fill tired, steel ball-bearing wheels. Trolleys shall be attached to the panels with adjustable steel pendant bolts with locks to prevent panel misalignment
- B. Track shall consist of heavy-duty aluminum alloy or steel. Track system shall be complete with overhead support features and brackets facilitating secure attachment to the building structure by means of adjustable steel hangar rods or by direct mount. The assembly shall be designed for the type, size, and weight of the partition selected and shall, in conjunction with the complementary trolley system, provide ease of operation.

2:06 SOUND SEALS:

- A. Vertical seals between panels shall consist of deep nesting, universal interlocking bronze steel astragals incorporating continuous, vinyl acoustical seals. Vertical astragal vinyl seals shall be installed on the outboard edges of the panel skins in a double row with an acoustical labyrinth.
- B. Horizontal TOP seals shall be continuous contact extruded vinyl shapes.

- C. Horizontal BOTTOM seals shall be 2 ½" clearance-type manually actuated at waist height on panel edges. Downward pressure of all clearance-type seal mechanisms shall assure an acoustical seal and resist panel movement

2.07 FINAL CLOSURE:

Final closure shall be as indicated on the project drawings and shall be accomplished by expandable panels.

2.08 FINISHES:

Vinyl Coated Factory Fabric Finish: FS CCC-W-408A, heavy-duty Type KK, 30 oz. Per linear yard, Class A flammability per ASTM-E84, color as selected from manufacturer's available range.

PART 3: EXECUTION

3.01 EXAMINATION:

- A. Examine flooring, structural support, and opening for compliance with requirements for installation tolerances and other conditions affecting performance of operable partition walls. Surfaces shall be clean and dry. Concrete surfaces shall be free of excess mortar and lumps. Wood surfaces shall be well nailed and/or glued, nail head driven flush, and wood free of voids. Metal surfaces shall be free of grease, oil, dirt, rust, corrosion and welding slag, without sharp edges. Do not proceed with installation until unsatisfactory conditions have been corrected.
- B. Verify that rough opening is correct and has been prepared by others to conform to ASTM E557-75 Standard.

3.02 INSTALLATION:

- A. Install operable panel partitions and accessories complying with ASTM E557 after other finishing operations, including painting, have been completed. Install operable panel partitions that conform to Architectural Drawings & Specifications, approved shop drawings and in strict compliance with manufacturer's written installation instructions.
- B. Match operable panel partitions for color and pattern by installing partitions from cartons in the same sequence as manufactured and packaged if so numbered. Broken, cracked, chipped or deformed panels are not acceptable.
- C. Apply perimeter caulking and trim and required.

3.03 ADJUSTING:

- A. Lubricate all system components, bearings and sliding parts, adjust to ensure smooth easy operation.
- B. Adjust locking hardware for accurate fit.

3.04 CLEANING

- A. Clean all wood, metal, vinyl, and plastic laminate surfaces to remove soil without using abrasive cleaners or solutions containing corrosive solvents.
- B. Remove debris from worksite.

3.05 DEMONSTRATION:

- A. Provide the services of factory-authorized service representative to demonstrate and train Owner's representatives. Test operation and safeties. Replace damaged equipment. Train Owner's representative on procedures and schedules related to operation, troubleshooting, servicing and preventative maintenance.
- B. Deliver all operation and maintenance manuals to the owner.

END OF SECTION

RELATED DOCUMENTS:

Drawings and general provisions of Contract, including General and Supplementary Conditions and Division-1 Specification sections, apply to work of this section.

PART 1: GENERAL

DESCRIPTION OF WORK:

Provide toilet and bath accessories as shown on drawings and as specified herein.

Provide blocking for Owner furnished/Owner installed items.

INDUSTRY STANDARDS:

For listing of names of industry standard agencies mentioned by abbreviation in this section refer to Section 01068.

QUALITY ASSURANCE:

Manufacturers:

For purpose of designating type and quality for work under this Section, Specifications are based on products manufactured by the Bobrick Co. and catalog numbers scheduled are Bobrick numbers. Equal items by McKinney/Parker, American Specialties, Inc. or Bradley will be acceptable.

SUBMITTALS:

Shop Drawings: Submit shop drawings or catalog cuts of each item required by this Section in accordance with General Conditions.

PART 2: PRODUCTS

Refer to Drawings Schedule for toilet accessory product descriptions.

PART 3: EXECUTION

INSTALLATION:

Items shall be securely anchored in place at heights and locations shown on drawings. In some areas heights and locations are not shown and accessories shall be located as directed by Architect.

Upon completion of work under this Section accessories shall be cleaned and polished in accordance with manufacturer's written instructions.

END OF SECTION

RELATED DOCUMENTS:

The general provisions of the Contract, including General and Supplementary Conditions, and General Requirements, and Division 1 specifications that apply to the work specified in this Section.

PART 1 - GENERAL

DESCRIPTION OF WORK:

Furnish and install the following:

1. PVC Corner Guards
2. Frameless Sliding Translucent Panel Door

RELATED SECTIONS

Section 05400 - Cold-Formed Metal Framing System
Section 09250 – Gypsum Drywall Systems
Section 09260 – Gypsum Drywall Framing
Section 09300 - Tile

QUALITY ASSURANCE:

Manufacturers:

Standard: For purposes of designating type and quality for work under this Section, Drawings and Specifications are based on products manufactured or furnished by Manufacturers listed with products.

SUBMITTALS:

Manufacturer's Data: Submit for approval three (3) copies of folder containing complete Manufacturer's data and installation procedures for all items to be furnished in work of this Section of Specifications.

Shop Drawings: Submit for each specialty item specified in accordance with General Conditions.

PART 2 - PRODUCTS

MATERIALS:

1. Corner Guards: InPro Corporation 160F (2") x 90 degree and 130F (3") x 135 degree (for all 45 degree corners) Flush Mount Corner Guard Systems or equivalent for all outside drywall corners, including one pair for each end wing wall condition, full height of wall, and also for each outside drywall corner of door frame conditions that expose an outside drywall corner, for the full height of the wall or door opening.
 - a. Provide full wall height corner guard systems that conform to the following requirements of regulatory agencies and the quality control of IPC Door and Wall Protection Systems, InPro Corporation.
 - b. Fire Performance Characteristics: Provide UL Classified corner guards conforming with NFPA Class A fire rating. Surface burning characteristics, as determined by UL-723 (ASTM E-84), shall be flame spread of 10 and smoke development of 350 - 450. Provide ULC (Canada) listed corner guards conforming to the requirements of the National Building Code of Canada 2010, Subsection 3.1.13. Surface burning characteristics, as determined by CAN/ULC-S102.2, shall be flame spread of 15 and smoke developed of 35.

- c. Self Extinguishing: Provide corner guards with a CC1 classification, as tested in accordance with the procedures specified in ASTM D-635-74, Standard Test Method for Rate of Burning and/or Extent and Time of Burning of Self-Supporting Plastics in a Horizontal Position, as referenced in UBC 52-4-1988. thickness as tested in accordance with the procedures specified in ASTM D-256-90b
- d. Detail Drawings: Mounting details with the appropriate adhesives for specific project substrates.
- e. Samples: Verification samples of corner guard, 8" (203mm) long, in full size profiles of each type and color indicated.
- f. Vinyl: Snap on cover of .080" (2mm) thickness shall be extruded from chemical and stain resistant polyvinyl chloride with the addition of impact modifiers.
- g. Aluminum: Continuous aluminum retainer of .070" (1.8mm) thickness shall be fabricated from 6063-T5 aluminum, with a mill finish.

COMPONENTS

- a. Cove Base Retainer: Cove base retainer shall be fabricated from 6063-T5 aluminum with a mill finish.
- b. Closure Cap: Closure cap shall be fabricated from .032"(.8mm) thick aluminum.
- c. Fasteners: All mounting system accessories appropriate for substrates indicated on the drawings shall be provided.

FINISHES

- a. Vinyl Cover: Color of corner guard to be selected by the Architect from the IPC finish selection standard colors. Surface shall have a pebblette texture.
2. Frameless Translucent Sliding Door/Panel: Provide 3-Form Model "Slide 01" frameless wall-mounted sliding panel door, with all required hardware for complete assembly. Featuring top track, roller with bearings assembly, floor tracks, floor guides, lower floor stop, upper wall stop, and stiffener handle. Varia Ecoresin translucent resin, selected by Architect from manufacturer's standard patterns, colors and textures. Satin anodized finish on track and the roller assemblies.

PART 3 - EXECUTION

INSTALLATION:

Install products in strict accordance with manufacturer's printed installation instructions. General Contractor shall coordinate requirements by other prime contractors.

END OF SECTION

RELATED DOCUMENTS:

Drawings and general provisions of Contract, including General and Supplementary Conditions and Division-1 Specification sections, apply to work of this section.

PART 1: GENERAL

1.1 SECTION INCLUDES

- A. Solid high density polyethylene (HDPE) toilet compartments, consisting of:
 - 1. HDPE Floor mounted overhead braced toilet compartments.
 - 2. HDPE Floor mounted overhead braced urinal screens.
- B. Compartment installation hardware.
- C. Compartment door hardware.

1.2 RELATED SECTIONS

- A. Section 10800 - Toilet and Bath Accessories.

1.3 SUBMITTALS

- A. Submit under provisions of Section 01050.
- B. Product Data: Manufacturer's printed literature indicating typical panel, pilaster, door, hardware and fastening.
- C. Shop Drawings: Submit five sets of the following:
 - 1. Dimensioned plans indicating layout of toilet compartments.
 - 2. Dimensioned elevations indicating heights of doors, pilasters, separation partitions, and other components; indicate locations and sizes of openings in compartment separation partitions for toilet and bath accessories to be installed in partitions; indicate floor and ceiling clearances.
 - 3. Details indicating anchoring components and methods for project conditions; indicate components required for installation, but not supplied by toilet compartment manufacturer.
- D. Samples: Two manufacturer's color cards representing manufacturer's full color palette.

1.4 DELIVERY, STORAGE AND HANDLING

- A. Store compartment components until installation in unopened cartons laid flat, with adequate support to ensure flatness and to prevent damage to prefinished surfaces.

1.5 ENVIRONMENTAL REQUIREMENTS

- A. Do not deliver materials or begin construction activities of this section until building is enclosed, with complete protection from outside weather, and building temperature maintained at a minimum of 60 degrees Fahrenheit.

1.6 SEQUENCING

- A. Obtain accessory manufacturer's installation instructions and installation templates for toilet and bath accessories to be installed in compartment separation partitions; supply instructions and templates to installer before beginning construction activities of this Section.

1.7 WARRANTY

Provide manufacturer standard 15 year warranty.

PART 2: PRODUCTS

2.1 MANUFACTURERS

- A. Acceptable Manufacturers: ASI Accurate, Global Partitions, equivalent products by Scranton
- B. Other manufacturers meeting the requirements of these specifications.

2.2 HDPE TOILET COMPARTMENTS

- A. Shall meet NFPA 286 Criteria Test results, and ASTM E-84 / UL 723 CLASS C flame spread rating.
- B. Panel:
 - 1. Nominal thickness: 1".
 - 2. Core: Panels shall be solid polymer resin, High Density Polyethylene (HDPE), which is waterproof, non-absorbent and resists marking, in colors that extend throughout the surface.
 - 3. Edges: Finished smooth.
- C. Floor Mounted Overhead Braced Pilasters:
 - 1. Nominal thickness: 1".
 - 2. Core: Pilasters shall be solid polymer resin, High Density Polyethylene (HDPE), which is waterproof, non-absorbent and resists marking, in colors that extend throughout the surface.
 - 3. Edges: Finished smooth.
 - 4. Pilaster installation hardware preparation: Two holes, diameter to accept 3/8 inch threaded rod, drilled into core at pilaster base end, parallel to pilaster vertical axis, intersecting centerlines of two holes, diameter to accept Plug-Loc® installation hardware, drilled through pilaster perpendicular to pilaster face and 1 inch from pilaster base end.
- D. Doors:
 - 1. Nominal thickness: 1".
 - 2. Core: Doors shall be solid polymer resin, High Density Polyethylene (HDPE), which is waterproof, non-absorbent and resists marking, in colors that extend throughout the surface.
 - 3. Edges: Finished smooth.

- E. Finish / Texture: Vandal resistant anti-graffiti texture, equivalent to Tough Texture (TT) raised dimple texture by ASI Accurate.
- F. Colors: Black

2.3 ACCESSORIES

- A. Pilaster Shoes: Heavy-Duty stainless steel pilaster shoes. Furnish shoes at each pilaster.
- B. Pilaster Anchors: Manufacturer's standard floor anchor with leveling adjustment assembly, concealed by pilaster shoe after installation.
- C. Pilaster, Wall Panel and Urinal Screen Brackets: All wall terminations and intersections are to be manufacturer's heavy duty, bright finish anodized aluminum continuous bracket, T profile with double anchoring flanges, pre-drilled at minimum 12" o.c. and prepared for exposed tamper-resistant fastening hardware. Bracket to be full height, length equal to the total length of partition, screen and pilaster less pilaster shoe height.
- D. Overhead Bracing: Continuous heavy duty .125" thick extruded aluminum head rail with anti-grip device profile, with integral reinforcing channel and curtain track. Bright anodized finish and 2" minimum height.

Provide head rail double eared female corner brackets, wall brackets, and head rail end caps, in bright polished finish.

- E. Door Hardware: (Heavy-Duty Cast Stainless Steel, unless otherwise noted)
 - 1. Door hinge: Heavy-duty 14 gauge stainless steel continuous hinge, self closing gravity type. All hinges shall be mounted a 1" thick stile member.
 - 2. Slide Latch: Heavy-duty, non-ferrous, cast stainless steel slide latch, satin finish, through-bolted.
 - 3. Strike and Keeper: Permitting emergency access by lifting the door until latch is clear of keeper; heavy-duty cast stainless steel, satin finish; through-bolted.
 - 4. Pull Handles: Heavy duty cast stainless steel with satin finish.
 - 5. Door Stops: Heavy duty cast stainless steel with satin finish.
 - 6. Coat Hook and Bumper: Non-ferrous, heavy-duty cast stainless steel, with black rubber tip for doorstop.
 - 7. Fastening Hardware: Manufacturer's heavy-duty, No.304 stainless steel, No.4 satin finish, through-bolts and attachment fasteners with tamper-resistant heads.
 - 8. Hardware of chrome-plated "Zamac" is unacceptable.
- F. Toilet and Bath Accessories for Installation in Compartment Separation Partitions: Specified Section 10800.

PART 3: EXECUTION

3.1 EXAMINATION

A. Verification of Conditions:

1. Measure areas to receive compartments; verify area dimensions are in accordance with shop drawings.
2. Verify built-in framing, anchorage, bracing, and plumbing fixtures are in correct location.

B. Installer's Examination:

1. Have installer of this section examine conditions under which construction activities of this section are to be performed, then submit written notification if such conditions are unacceptable.
2. Transmit two copies of installer's report to Architect within 24 hr of receipt.
3. Beginning construction activities of this section before unacceptable conditions have been corrected is prohibited.
4. Beginning construction activities of this section indicates installer's acceptance of conditions.

3.2 PREPARATION

A. Surface Preparation:

1. Prepare openings in compartment separation partitions for toilet and bath accessories to be installed in partitions; marring of partition finish is prohibited.
2. Locate openings in accordance with shop drawings and accessory manufacturer's installation instructions and templates.

3.3 INSTALLATION

- A. Install compartments to specified tolerances in accordance with shop drawings and manufacturer's printed installation instructions.
- B. Attach components to adjacent materials and to other components using purpose-designed fastening devices.
- C. Adjust pilaster anchors for floor variations; conceal anchors with pilaster shoes.
- D. Equip each compartment door with top and bottom hinges, and door latch.
- E. Install door strike keeper on pilasters in alignment with door latch.
- F. Equip each compartment door with one coat hook and bumper.
- G. Installation Tolerances:
 1. Maximum variation from plumb or level: 1/8 inch.
 2. Maximum displacement from indicated position: 1/8 inch.
 3. Clearance between wall surface and panels or pilasters: 1-1/2 inch maximum.

3.4 ADJUSTING

- A. Adjust door hardware for uniform clearance between doors and pilasters.
- B. Adjust door hinges to attain free movement, to locate in-swinging doors in partial open position when unlatched; and to return out-swinging doors to closed position.
- C. Adjust door hardware to align door strike keeper on each pilaster with door latch.

3.5 PROTECTION OF INSTALLED PRODUCTS

- A. Prevent damage to product finishes by subsequent construction activities.
- B. Replace components having damaged finish.
- C. Remove factory protective coverings and clean finish surfaces in accordance with manufacturer's instructions before final inspection.

END OF SECTION

RELATED DOCUMENTS:

Drawings and general provisions of Contract, including General and Supplementary Conditions and Division-1 Specification sections, apply to work of this section.

GENERAL

Provide projection screens as indicated, with all necessary accessories and mounting hardware for providing complete and operational assemblies.

Product Data: Submit manufacturer's product data, for each type of screen indicated.

Electrically-Operated REAR Projection Screen

(1 REQUIRED; Multi-Purpose 518 Platform): 120" (H) x 240" (W).

Provide product equivalent to Da-Lite "Tensioned Large Advantage Deluxe Electrol" (for rear screen projection). Mounted within Prosceniums.

The Tensioned Advantage® Deluxe screen shall have two motors, one to operate door and one to operate screen. Door motor electrically operated 120 volt (60 Hz) not more than 1.2 amp. Shall have motor mounted inside the roller, to be three wire with ground, quick reversal type, oiled for life, with automatic thermal overload cutout, integral gears, capacitor and an electric brake to prevent coasting. To have pre-set but adjustable limit switches to automatically stop fabric door in the "down" position. The door will lift to the closed position where a micro switch shall cut off the electrical current to the door motor. The roller to be of 1.6" diameter aluminum. Screen motor is electrically operated 120 volt (60 Hz) not more than 2.4 amp. Shall have motor mounted inside the roller, to be three wire with ground quick reversal type, oiled for life, with automatic thermal overload cutout, integral gears, capacitor and an electric brake to prevent coasting. To have pre-set but adjustable limit switches to automatically stop picture surface in the "up" and "down" positions. The fabric roller to be of 4½" diameter (5¾" if 270" diagonal, 275" diagonal, or 298" diagonal) metal. Screen fabric to be seamless, flame retardant and mildew resistant vinyl, with black masking borders standard. Each side of the fabric to have tab guide cable system to maintain even lateral tension and hold surface flat. Custom slat bar with added weight maintains vertical tension on the screen surface. The ends of the slat to be protected by heavy duty plastic caps enclosing a preset adjustable mechanism for screen tensioning. Case shall be a white powder coated extruded aluminum. Bottom of case to be self-trimming with a built-in flange around the bottom of the case. A section of the bottom of the case shall be a retractable aluminum door that opens and closes automatically with the lowering and raising of the picture surface. The balance of the bottom of the case shall be a second hinged aluminum door with manual opening to provide access. Hinges shall be mounted in a concealed way. Junction box shall be internally integrated into the housing making it possible to install the housing and wire to the building's electrical system during construction. The junction box shall contain a quick connect connector that is mounted in the housing for easy plug-in connection to the motorized fabric and roller assembly. The motorized fabric and roller assembly to be installed in the case at the factory or at a later time at the job site. To be complete with integrated low voltage control unit and three position control switch with cover plate. Suitable for use in environmental air space in accordance with section 300-22 (c) of the National Electric Code, and sections 2-128, 12-010 (3) and 12-100 of the Canadian Electrical Code, part 1, CSA C22.1. Screen to be listed by Underwriters' Laboratories.

Viewing Surface: Equivalent to Da-Lite "Dual-Vision" (for rear screen and front projection).

Options: 24" extra drop.

Mounting: Type 1. Offset mounting (CENTER THE SCREEN, NOT THE UNIT, INSIDE PROSCENIUM).

Provide hangers, blocking, and all necessary items for rigid installation to building.

Installation:

General: Install projection screens at locations indicated in compliance with screen manufacturer's instructions.

Install projection screens with screen cases in position and relationship to adjoining work indicated, anchored to supporting substrate, to produce an operating screen with plumb and straight vertical edges and plumb and flat viewing surfaces when lowered.

Protect projection screens during and after installation from damage during construction.

END OF SECTION

RELATED DOCUMENTS:

The general provisions of the Contract, including General and Supplementary Conditions, and General Requirements, apply to the work specified in this section.

PART 1: GENERAL

DESCRIPTION OF WORK:

Work of this Section shall be to provide stage curtains complete assembly shown on the Drawings and as specified herein, at PLATFORM 134.

SUBMITTALS:

Manufacturer's Data: Submit for approval three (3) copies of folder containing complete Manufacturer's data and installation procedures for all products to be used in work of this Section.

Shop Drawings: Submit Shop Drawings in compliance with GENERAL CONDITIONS. These drawings shall be coordinated with adjacent work.

PRODUCT HANDLING:

Working Areas: Provide suitable areas for storage of materials and equipment.

Delivery: Deliver products to site in original sealed containers or packages bearing Manufacturer's name and brand designation.

PART 2: PRODUCTS

See Drawings for Stage Curtain requirements or Schedule. Provide complete assembly.

Stage curtains shall be selected by Owner; colors to be selected by Architect from manufacturer's standard colors. All stage curtain material shall be 100% flame resistant, Class A rated. Provide manufacturers' certification for Class A rating sewn into bottom of curtain.

PART 3: EXECUTION

INSPECTION

Examine all surfaces to which products are scheduled to be installed. If unsatisfactory conditions exist, report to General Contractor and do not proceed with work until conditions have been satisfactorily corrected.

INSTALLATION:

Install stage curtains in accordance with Manufacturer's printed instructions and approved Shop Drawings.

All installations shall be performed by capable workmen under direction of foreman fully qualified by experience in each respective field of installation work.

END OF SECTION

RELATED DOCUMENTS:

The general provisions of the Contract, including General and Supplementary Conditions, and General Requirements, and Division 1 specifications that apply to the work specified in this Section.

PART 1 - GENERAL

DESCRIPTION OF WORK:

Work of this Section shall be to provide new interior scoreboards, basketball goals, and athletic equipment as shown on Drawings and specified in this Section.

INDUSTRY STANDARDS:

For listing of names of industry standard agencies mentioned by abbreviation in this Section, refer to Section 01068.

QUALITY ASSURANCE:

Manufacturers Standard: For purpose of designating type and quality for work under this Section, Drawings and Specifications are based on products manufactured by Fair-Play, Performance Sports Systems, Inc. Other Manufacturers who can furnish equivalent products or systems of same materials specified will also be acceptable.

SUBMITTALS:

Manufacturer's Data: Submit for approval three (3) copies of folder containing complete Manufacturer's data and installation procedures for all products to be used in work of this Section.

Shop Drawings: Submit Shop Drawings in compliance with GENERAL CONDITIONS. These drawings shall be coordinated with adjacent work.

PRODUCT HANDLING:

Working Areas: Provide suitable areas for storage of materials and equipment.

Delivery: Deliver products to site in original sealed containers or packages bearing Manufacturer's name and brand designation.

PART 2 – PRODUCTS

BASKETBALL GOALS

Interior Side-Folding Goals: Provide wall mounted side-folding goals where indicated, Performance Sports Systems, Inc. Model 2500 Wall Mount Adjustable Side Folding, goal with tempered glass backboards Model 942. Backboards to have painted targets and bolt-on safety cushion edges Model 1330. Provide breakaway goals Model 2000+. Provide each with manual height adjuster Model 1130, Adjust-A-Goal Series, featuring height adjustment from 8'-0" to 10'-0" with hand held removable crank.

Wall mount structure consists of four 1 7/8" O.D. tubes telescoped inside 2 1/8" O.D. tubes, spaced at 63" centers for standard application and 35" centers for fan-shaped backboards. The bottom horizontal tubing shall be braced with diagonal telescoping pipes that lock in playing position. All pivot points are offset to allow for maximum fold. All critical fittings shall be malleable iron castings, heavy gauge steel

stampings, or weldments. Backstop manufactured in accordance with all NCAA, NFHS, NBA requirements.

Wall attachment Unit shall be attached to 2 x 8 (1.5" x 7.25") clear coated #2 Southern Yellow Pine wood pads. Units will be additionally supported by 5/0 chain fastened at the front of the unit and attached to wood pad mounted on wall. Wood pads to be mounted to minimum 8" solid core concrete block wall or wall of similar integrity. All critical fittings shall be heavy gauge steel stampings or weldments. Through bolting of the wood pads to the wall are recommended or anchored with anchors rated for minimum of 5 times the loads shown for the unit being installed.

Finish: Backstop units and framing shall be factory prime coated and factory pre-finished in manufacturer's top coats of powder coated **WHITE** enamel. Manufacturer to provide necessary matching touch-up paint supplies.

Exterior Fixed Height Basketball Goal and Backstop (installed / complete assembly):

Model: PK3535 Economy 3-1/2" O.D. Gooseneck Basketball Package; includes Model GN35 Gooseneck Pipe Post, Model 1750B Backboard, Model 39WO Rim, by Performance Sports Systems, Inc.

Gooseneck design to extend backboard 48" out from the post. 3 1/2" O.D. galvanized steel pipe. Goal is direct attached to post with mounting plate, double-arm braced. Two braces extend from upper mounting points on backboard to the gooseneck for rigidity.

Post mast for direct bury shall extend into a concrete footing 36" minimum deep embedment. Concrete footing provided by the installer. Pipe shall meet or exceed ASTM A513 structural steel specifications.

36" fan shaped aluminum backboard.

Institutional economy fixed single rim goal with no-tie net attachment. Orange powder coat finish, complete with chain net and hardware.

Finishes: Backstop post shall be galvanized. Aluminum backboard shall be factory prime coated and factory pre-finished in manufacturer's top coat of powder coated **WHITE** enamel, with silk-screened target striping. Manufacturer to provide necessary matching touch-up paint supplies.

Wall Mats: Provide Porter 2" thick Model 00350-300 2' x 6' with "Vonar" fire retardant, "zee" clip attachment. Provide sections 6' high x total width shown and in configurations indicated on Drawings, including corner pad conditions.

PART 3 - EXECUTION

INSPECTION

Examine all surfaces to which products are scheduled to be installed. If unsatisfactory conditions exist, report to General Contractor and do not proceed with work until conditions have been satisfactorily corrected.

All wall mounted and overhead mounted equipment locations shall be fully coordinated with all adjacent systems, including mechanical, electrical, lighting and flooring, prior to installations.

INSTALLATION:

Install all specified systems in accordance with Manufacturer's printed instructions and Shop Drawings, approved by Architect.

All installations shall be performed by capable workmen under direction of foreman fully qualified by experience in this field of installation work.

Provide Owner with training sessions and demonstrations, performed by fully qualified manufacturers representatives certified in this field of installation work.

END OF SECTION

RELATED DOCUMENTS:

Drawings and general provisions of Contract, including General and Supplementary Conditions and Division-1 Specification sections, apply to work of this section.

WORK REQUIRED:

- A. The work to be done under this contract shall include the furnishing of all labor, materials, equipment, and services necessary for and reasonably incidental to the proper completion of all Kitchen Equipment Construction, as shown on the plans and herein specified, excepting only work or materials specified or noted as being done or furnished by others.
- B. The attention of this contractor is directed especially to the section herein referring to "CONNECTIONS TO EQUIPMENT FURNISHED AND INSTALLED BY THE CONTRACTOR".

GENERAL:

- A. The General Conditions, Supplementary General Conditions, Instructions to Bidders, Drawings, and these specifications constitute the necessary documents for this part of the work, a copy of same being bound herewith. The contractor shall be bound by these, and, wherever the word "Architect" shall appear, it shall be understood that this shall include the duly accredited representative of the Architect. It should be understood that the mechanical plans are diagrammatic in character but should be adhered to as closely as possible, consistent with construction of the building. Mechanical plans should not be scaled. Secure dimensions from Architectural Drawings.
- B. All work shall be executed in a workmanlike manner by skilled mechanics and shall present a neat appearance when completed.
- C. The plans and these specifications are intended to completely describe, imply, and convey the materials and equipment, as well as necessary labor, required for the installation as hereinafter specified.
- D. It shall be understood that, where the words "furnish" and/or "install" are used, it is intended that this Contractor shall purchase and install completely all materials required. All materials shall be new.
- E. It shall be the duty of the Contractor to submit, to the Architect, within twenty (20) days following award of the contract, a complete list of materials proposed for the project, as hereinafter outlined. Where the name of a particular manufacturer is mentioned in connection with materials, this shall be construed to be for descriptive rather than restrictive purposes.
- F. If substitutes are equal in every respect to those as specified, in the opinion of the Architect, they will be approved according to procedure, as outlined hereinafter. Contractor will be allowed to submit, for approval, one (1) submission of a substitute item. If the substitute items are not in compliance with the plans and specifications and are disapproved, the contractor will be required to furnish and install specified materials.
- G. All materials and submittal data must be reviewed, processed and coordinated with all other Contractors, before any Contractor proceeds with installing kitchen equipment associated materials or items in the Project.
- H. In some cases, it may be required that samples of materials be submitted for approval. Any such samples submitted will be returned to the Contractor or manufacturer on request.

- I. This Contractor shall obtain and pay for all permits and/or fees required, give required legal notices, and notify inspection departments.
- J. The drawings, which accompany these specifications, are not intended to show, in complete detail, every fitting which may be required; however, wherever reasonably implied by the nature of the work, such materials or equipment shall be installed by this contractor as a part of his contract price. Contractor shall be responsible for all drawings and all specifications, which shall include those for each allied trade involved in the construction of the project.
- K. In no case will any extra charge be allowed unless authorized, in writing, by the Architect.
- L. All plumbing shall be done in strict accordance with the sanitary laws and other laws of the State of North Carolina. Each fixture shall be properly trapped and vented as shown or required by Codes.
- M. Piping shall be supported in place to the satisfaction of the Architect. Use approved hangers as hereinafter specified.
- N. Should these specifications or the plans, which accompany them, not be entirely clear to the Contractor as to the intent or scope of work, the contractor shall request clarification, in writing, to the Architect, before the bid opening date.
- O. All electrical work shall be done in strict accordance with the laws of the North Carolina State Building Code, which includes the current Edition of the National Electrical Code and the Division of this specification entitled "ELECTRICAL".

CONTIGUOUS WORK:

- A. If any part of this contractor's work is dependent for its proper execution or for its subsequent efficiency or appearance, on the character or conditions of contiguous work not executed by him, the Contractor shall examine and measure such contiguous work and report to the Architect, in writing, any imperfection therein, or conditions that render it unsuitable for the reception of this work. Should the Contractor proceed without making such written report, he shall be held to have accepted such work and the existing conditions, and he shall be responsible for any defects in this work consequent thereon and will not be relieved of the obligation of any guarantee because of any such imperfection or condition.

PROTECTION OF EQUIPMENT:

- A. The Contractor shall be responsible for all work damaged by him in executing the contract. Any work damaged will be replaced by him and placed in perfect working condition without extra cost. The Contractor shall, at all times, be responsible for any damaged equipment or work in conjunction with executing contract. All fixtures and fittings shall be adequately protected before and after installation.

BOILER INSPECTION:

- A. It shall be the responsibility of the contractor to complete the installation of the fired and unfired pressure vessels and their safety devices, in accordance with the requirements of the latest Edition of the North Carolina Boiler Inspection Law, Rules, and Regulations. This Contractor shall have the equipment, which is installed under this contract, inspected and approved by the State of North Carolina, Department of Boiler Inspections. This contractor shall be responsible for

notifying the State Boiler Inspector, in writing, at least two (2) weeks prior to the date of completion, of all equipment requiring inspection.

- B. Furnish and install a suitable metal frame, having a removable glass cover, for posting the certificates of inspection furnished by the North Carolina Department of Labor, Boiler Bureau. Certificates are to be installed in frames by this contractor before requesting final inspection of the completed job by the Owner and Engineer.
- C. Final payment will not be made until such a certificate has been duly posted. All fees and expenditures, necessary for this requirement, will be paid by the Contractor.

CHASES, CUTTING, AND PATCHING:

- A. In new construction, chases in walls, for any work to be installed by this contractor, will be provided by the general contractor, provided full information as to the location and size of such chases and the necessary frames for openings is given to him by this contractor in such time as to cause no delay in the General Contractor's work.
- B. If this Contractor should neglect to furnish the required information and, by reason of his neglect, chases and openings are not provided, this contractor shall, at his own expense, cut the required chases and openings and make such repairs as shall be necessary to restore the work to its original finish.
- C. The cutting of chases, openings, or holes, in floors and ceilings, shall be done in a manner as not to endanger the stability of the structure or any part thereof. The Contractor shall not, in any case, cut or alter the work of any other contractor without the approval and under the direction of the Architect or Engineer. All repairs, resulting from cutting, shall be done under the supervision of the Superintendent of the General Contractor.

SCOPE OF WORK:

- A. This Contractor shall be required to perform all work specified and shown on drawings to provide systems as shown. Kitchen Equipment Contractor shall set all equipment in place and provide all required and necessary accessories for complete assemblies. Final and terminal connections to rough-ins will be the responsibility of the Plumbing, Mechanical and Electrical Contractors. The work will consist of the following items in general:
 - 1. **SUBMITTALS:** Complete a kitchen equipment submittal phase of all proposed kitchen equipment work. Submittal data shall include individual equipment product data and shop drawings clearly indicating compliance by description of properties, features, accessories, with plan drawings of equipment layout and plan drawings of equipment individual utility rough-in locations. Submit utilities schedules showing utility requirements and required connections for each kitchen equipment item; to include but not necessarily limited to: electrical service requirements, breaker and circuit sizes, water supply data, waste drain data, gas supply data with working gas pressure requirements.

COORDINATION: Upon completion of submittals processing, Kitchen Equipment Contractor shall provide coordination copies of all processed submittals with General, Electrical, Plumbing and Mechanical Contractors. Claims from any party for additional costs, that are attributed to or due to inadequate coordination with processed submittals will not be considered.

- 2. Furnish and install all purchased items of kitchen equipment, with Connections to electrical and plumbing services provided by the Electrical and Plumbing Contractors.

3. Fabricate and install all items of fabricated equipment as shown on plans, with all plumbing connections to both plumbing and electrical work provided by the Electrical and Plumbing Contractors, to provide service for the equipment.
4. Plumbing Contractor shall furnish all water and waste piping terminal connections to the equipment from roughed piping, which is furnished, installed and capped or plugged at the wall or floor by the Plumbing Contractor.
5. Kitchen Equipment Contractor shall furnish all electrical control devices, and safety equipment for the kitchen equipment.
6. The Kitchen Equipment Contractor is to refer to plumbing plans, heating and air conditioning plans and electrical plans for portions of the work that are furnished and installed by the above referred Contractors. All terminal connections from the facilities and provisions described shall be provided by the Plumbing, Heating and Air Conditioning and Electrical Contractors.
7. Kitchen Equipment Contractor is to furnish and install all necessary plumbing trim including faucets and waste traps assemblies as indicated on drawings, and as specified herein.
8. Heating and Air Conditioning Contractor is to furnish and install all necessary local gas regulators necessary for maintaining required working gas pressure for gas fired kitchen equipment.
9. Prior to acceptance and use, Kitchen Equipment Contractor is to perform testing of each piece of equipment, confirming its proper operation. Kitchen Equipment Contractor shall be the responsible party to coordinate any work necessary to bring any non-compliant equipment into compliance.

TRAINING:

- A. Kitchen Equipment Contractor shall have factory trained and certified product representatives provide equipment and system training sessions for the Owner for each individual kitchen equipment product and system. Sufficient training shall be provided to the extent that each Owner attendee is fully versed on the product and/or system and can be a designated "trained" participant, and that each participant can demonstrate the ability to operate each product and system in total variety of operations. Provide multiple training sessions if such is required to be certified as fully trained personnel. An Owner Training Certification is to be provided. Submit an affidavit that each required Owner training session has been performed. Submitted affidavit to include sign-up log of attendees/trainees and description of system or product, cross referenced to the specific contract document.

WASTE PIPING:

- A. Unless otherwise specified or shown on plans, all below floor waste piping shall be service weight, coated, cast iron soil pipe, conforming to CISP Std. 301-68T, no-hub above grade only, Charlotte Seal below grade. Standard galvanized steel pipe shall be used instead of cast iron, in places where under 2" is needed.
- B. All exposed soil pipe, lines and fittings to be brushed finish stainless steel. To include indirect waste piping to floor sinks or floor drains. Support from equipment or floor with stainless supports per manufacturer written instructions

- C. Exposed soil pipe connections to sinks, individual bowls or basins, hot water discharging fixtures, shall be individually piped to floor sinks and floor drains with not less than 2" O.D. brushed finish stainless steel pipe. Support from equipment or floor with stainless supports per manufacturer written instructions.
- D. Joints shall be made in accordance with requirements of the State Plumbing Code.
- E. Fittings for galvanized waste lines shall be recessed drainage iron fittings, galvanized, interior shoulder type, providing a smooth waterway of the same diameter as inside of pipe. The tappings shall be chamfered, permitting easy entrance of pipe threads. Fittings shall be tapped to pitch, 1/4" per foot. All threads shall be clear-cut and full. Fittings shall be free from rust, scale, and holes, or other imperfections. All fittings, for vent pipelines, shall be Standard, galvanized, malleable iron fittings.
- F. Contractor should note that all fittings for cast iron waste piping shall be sanitary drainage type fittings. Tapped tees or tapped crosses will not be permitted for connections of waste to vertical risers or any connection to vertical risers to horizontal line.

JOINTS AND FITTINGS:

- A. All changes in horizontal direction of soil and waste lines shall be made with long radius fittings or with "Y" branches and 1/8 or 1/16 bends.
- B. Unions to be used in erection of all piping so that piping may be taken down without breaking fittings. Concentric reducing fittings shall be used to make reductions in all sizes of piping.
- C. All cast iron pipe shall be made up with oakum and hot lead, using a minimum of one pound of lead per inch of pipe diameter, and in sufficient quantity to completely fill bell in one pouring.
- D. All screw piping and shall be made up by applying pipe dope to male thread of pipe.
- E. All copper piping shall be made up, using 95-5 solder.
- F. 50-50 solder will not be allowed on the job for any use.
- G. All connections from valves or stop valves to fixtures to be armor braided flexible connector hose type.

WATER PIPING:

- A. General:
 - 1. The Contractor shall perform all work and supply all materials required to produce an adequate supply of water to all fixtures requiring same. Distribution lines shall be installed as shown on plans.
 - 2. All water piping, unless otherwise noted or specified hereinafter, shall be thin-walled copper water tubing, Type "K", soft, below ground; and Type "K" hard, above grade, conforming to ASTM Specifications B-88. The fittings shall be wrought copper of the same composition as the tubing, conforming to ASA Specifications B-1 6-22. Fittings shall be marked with manufacturer's name or trademark. Solder, used for fittings 1-1/2" and larger, shall be Silphos, Easy-Flo Phos-Copper, or approved equal. Use 95-5 solder for fittings, 1-1 /4" and smaller. 50-50 solder will not be allowed on the job for any use. One-half inch (1 /2") tubing shall be the smallest size allowed. In making soldered joints,

all surfaces must be clean and shiny and coated with flux; this applies to ends of tubing and inside of fittings. After fluxing the surfaces, the tubing shall be pushed into the fittings as far as the fitting shoulder and held there. Apply heat to joint until the flux begins to boil. After heating the fitting, apply solder to the edge of the fitting or to the solder feed hole (if fitting is furnished with one), until the solder melts and flows into the joint, continuing to feed the solder until it has penetrated to the shoulder of the fitting. Quickly, wipe off the excess solder with a brush or cloth and let fitting cool without being disturbed.

3. All exposed water piping to plumbing fixtures and kitchen equipment items, shall be IPS chrome-plated yellow brass pipe with polished chrome-plated 125-pound screwed brass fittings. Any joints leaking shall be reconstructed with new materials. Flexible pipe or hose is not acceptable for final connection to any fixture on this project.
4. Pipe and fittings shall be marked with manufacturer's name or trademark.

VALVES:

- A. Valves shall be installed at all points noted on drawings by Standard symbols or as required by best general practice for proper control and operation of the system.
- B. Valves furnished and installed shall be the following or equal as approved in writing by the Architect/Engineer. All valves furnished shall be of the same manufacturer.

SCREWED ENDS, UNION BONNETS (Globes with Composition or Teflon, as Specified):

	<u>Gates 125# WSP</u>	<u>Globes 150#WSP</u>	<u>Checks 125# WSP</u>
Jenkins	62-U	106-A	92-A
WalWorth	3	95	406
Nibco	T-I 25	T-235-Y	T-413-B

SOLDER ENDS, SCREWED BONNET GATES, UNION BONNET GLOBES (Globes with Teflon Discs).

	<u>Gates 125# WS</u>	<u>Globes 150# WSP</u>	<u>Checks 125# WSP</u>
Lunkenheimer	2132	126	2145
Nibco	S-121	S-235-Y	S-413-B
Walworth	55 SJ	95 SJ	406 SJ

- C. All valves shall be the product of one manufacturer and shall be identified by catalog number with a metal disc under the handle.

UNIONS:

- A. This Contractor shall furnish and install, at necessary locations throughout the water piping system, a sufficient number of unions required to facilitate removal of pipe, equipment, or valves.

HANGERS, ETC:

- A. All piping, around walls, shall be supported in a satisfactory manner, using pipe clamps as directed.

- B. Hanger rods shall have sufficient threads to insure proper adjustment of pipe grades, etc. Hangers shall be installed no more than 18" from point where piping changes direction.

PLACING IN SERVICE:

- A. Upon completion of the entire installation, the complete system and equipment shall be tested by actual operation to prove that same will function as intended.
- B. This Contractor shall place the entire system in a satisfactory operating condition and shall furnish all assistance and instruction required by the Owner's representative during initial operating period.

CLEANING:

- A. It is the kitchen equipment contractor's responsibility to turn over to the Owner all equipment in clean condition. It is the kitchen equipment contractor's responsibility to see that all pipelines are free from debris when job is turned over to the Owner. Any damage, to kitchen equipment, before final acceptance, regardless of by whom caused, shall be repaired or replaced by the Kitchen Equipment Contractor without additional cost to the Owner.
- B. The Kitchen Equipment Contractor shall acquaint the Owner's representative with the special parts required for the operation of the flush valves, furnished and installed for the project.

ELECTRIC WIRING:

- A. The Electrical Contractor shall furnish service, as indicated on plans, at appropriate location, for connection to all kitchen equipment furnished by this contractor. This Contractor will furnish all materials, equipment, disconnects, safety devices, contactors, etc., necessary for operation of the equipment. All wiring will be in accordance with the electrical specifications and in general, all wiring from the outlet furnished by the Electrical Contractor to the equipment furnished by this Contractor will be the same size as the wire installed by the electrical contractor. All wiring from outlets furnished by the Electrical Contractor to the equipment in wet locations and in the center aisle under the range hood will be in weathertight Greenfield conduit with appropriate weathertight fittings.

WATER AND WASTE CONNECTIONS:

- A. In general, the Plumbing Contractor will furnish and install capped or plugged waste connections of appropriate size and at appropriate locations for connections of waste from all kitchen equipment furnished by this Contractor. This Contractor will furnish all waste lever fittings, all traps, all waste piping, etc., necessary for complete connections of waste from the equipment.
- B. In general, the Plumbing Contractor, when necessary, will furnish gate valve stops on water piping at the appropriate location for connection to the equipment furnished by this contractor. Where gate valves are not deemed necessary, capped copper pipe will be provided for connections to the equipment. The Kitchen Equipment Contractor will furnish all water piping from the outlet provided by the Plumbing Contractor to the equipment with final terminal connection to the equipment including all necessary faucets, trim, etc., for operation of the equipment.

KITCHEN EQUIPMENT:

- A. General:

1. The Kitchen Equipment Contractor is to furnish and install all items of kitchen equipment indicated on the plans. The kitchen equipment is to be furnished and completely connected as required and ready for operation at time of final inspection. The kitchen equipment contractor will make arrangements with the kitchen equipment manufacturers' including dishwasher to supply the necessary on-site demonstrations, instructions and operating manuals to the Owner regarding operation of the equipment.

B. Materials & Connections:

1. All equipment shall meet National Sanitation Foundation Standards and must be UL approved and must be labeled.
2. All custom-built equipment shall be designed for extra heavy use equal to make and/or details and specification hereinafter noted.
3. Description of materials herein specified are to be understood to be the minimum standards.
4. Stainless Steel: Type #302, AISI finish; to match the #3 mill finish or #100 emery grit finish.
5. White Metal: Not less than 21 % nickel with a corrosive-resisting quality similar to that of polish and buffed to a bright luster.
6. The Plumbing Contractor is to include all roughing of water and waste for kitchen equipment as required. His water connections will be roughed and equipped with globe valve stops. Waste connections will be include water and waste connections to the equipment in satisfactory operating condition.
7. The Electrical Contractor will furnish all necessary roughing of electrical services at the location indicated on the electrical plans for the kitchen equipment. In some instances the electrical contractor will rough conduit through the floor with outlet boxes or conduit through the floor for connections to the equipment. In some cases, the Electrical Contractor will rough wall outlets or wall receptacles for service to the kitchen equipment. Where conduit or outlet box connections are necessary they will be extended from the outlet furnished by the Electrical Contractor utilizing watertight Greenfield connections with complete electrical connections ready for operation to the kitchen equipment.
8. Galvanized Iron: ASTM A 93 latest edition
9. Structural Steel Shapes: As shown and/or noted.

C. Fabrication:

1. All welding done with welding rods of same composition as sheets or parts being welded. All exposed welded joints to be of same color as adjoining metal surfaces.
2. No field joints accepted.
3. All welded joints ground and polished to match adjoining surfaces.

D. Construction Methods:

1. Sink and Table Legs:

- a. Legs 1 5/8" O.D. x 14 gauge stainless steel tubing with 1" O.D. x 16 ga. stainless steel tubing cross bracing located 10" above the floor.
- b. Joints closely mitered and completely welded all around.
- c. Bottom of legs fitted with stainless steel sanitary shape adjustable feet. Industrial Foundry No. 638. Provide not less than 1" adjustment.

E. Sink and Sink Tops:

1. 14 ga. stainless steel
2. Reinforced on underside with 14 ga. 1 " x 4" x 14 galvanized iron channel battens placed not greater than 36" o.c. short dimension. No rivet heads in top or sides.
3. Drain boards integrally welded with splash and front rim and sink. 10" high back splash with 2 holes of proper size, 8" O. C. centered above each sink. Located at proper height to receive faucet to be furnished and installed by this contractor.
4. Front edge and ends to turn up 3" high except at sink area which shall drop to level of sink portion (14").
5. Front ends and back splash to be formed over 1 1/2" diameter die.
6. Sinks 14" deep. Each compartment to have 2" IPS threaded waste outlet of chromium plated brass with built-in 2" lever operated waste valve and removable stainless steel strainers held in place by at least two stainless steel flat head screws. Sink shall be integral part of adjacent units.

Coordinate necessary sink depth adjustments at disposal installation locations.

7. Drain boards 1 1/2" rolled spillage type edges with splash back to match sink back.
8. Corners of sinks drain boards and dish tables shall be square with fillet beads in all welded corners.

F. Lower Shelves:

1. 16 ga. stainless steel, snap-on type, removable.

SERVING LINE:

Furnish and install the below listed food service equipment. Fiberglass body colors to be selected by Architect. Submit Shop Drawings for approval. Approved serving line manufacturer is and basis of design is: LOW TEMP INDUSTRIES LTI/SPECLINE (formerly Colorpoint). Equivalent products by DELFIELD, RANDELL and VOLLRATH are acceptable.

Tops to be 30" wide and fabricated from 14-gauge stainless steel with square turn downs on all sides and corners fully welded, ground and polished. Tops to have #4 satin finish and all edges having #7 hi-lite finish.

Body to be seamless molded fiberglass (F.R.P.) with smooth exterior surfaces and rounded corners. All fiberglass to be flame retardant per specification ASTM-E162. All bodies are to be constructed by hand lay-up process with four layers of 1.5 oz. continuous strand fiberglass matt, plus 24 oz. layer of woven roving on the bottom for added strength. All bodies are to be open base construction with stainless steel interior seamless liners and stainless steel doors, unless otherwise specified. Open base spaces are to be available for localized capture of daily condensate or waste draining. Provide 12 gauge "U" channels to reinforce shape of fiberglass bodies. The use of the full internal channel is to insure that load stresses are placed on the channel and not on the fiberglass body. An additional external channel is to be placed between the casters and the bottom of the counter to further relieve any other purposes. Tray slides are to be constructed so not to sag as a result of the reinforced "U" channel application.

Fiberglass body colors to be selected by Architect, from manufacturer's RAL color choices, minimum of 180 color choices. Color of the fiberglass is to be confirmed by the Architect at the time of the submittal drawing presentation by awarded dealer.

Tray slides are to be 10" flat surface with parallel inverted "V" type pencil ribs, stainless steel with ends and sides turned down square and all corners fully welded, ground and polished. Support brackets are to be stainless steel fold down type and field adjustable with a screwdriver.

Casters are to be 5" diameter, ball bearing, swivel type casters, non-marking and with locking brakes on all wheels. Casters to be mounted with exterior and interior bracing for maximum stress relief.

All tables are to be furnished with line up locks. Locks to be barrel bolt and key slot design with cam locking action. Locks to be placed on opposing corners for maximum locking capability.

Hot food tables, as required, furnished with dry/moist hot food wells to be bottom mounted and have 12" x 20" die-stamped openings with 1/4" raised beaded edge. Hot wells to be recessed 1" for serving. All hot food wells are to have energy saving 500 watt heat blanket wrap pans, with double poled thermostat for temperature control. Each hot food well to have a copper drain line with drain screen cover plates, plumbed to a common drain manifold with a drain cock shut-off valve for directed daily flow into a localized capture device stored within the open base space. All switches and controls are to be fully accessible. All wells are wired to a circuit breaker for current overload protection and on/off controls. All sneeze guards are to be furnished with factory installed LED lighting fixtures and wired to the central control panels to meet NSF and UL standards.

Cold Food Table, as required, to be Mechanically cooled and in compliance with NSF-7 standards for Mechanical cold pans. Pan to have removable fans that circulate cold air. Pan shall be 18-gauge stainless steel and be 9" deep, with food pans flush with counter tops. The welded watertight pan shall have Temp-est Air refrigeration system. The system to include low velocity axial fans and advanced design cold wall. Pan to be fully insulated with urethane insulation and the top shall be separated from the pan by a full perimeter breaker strip. The cold pan to have a 1" open brass drain with copper drain line to a drain cock shut-off valve for directed daily flow into a localized capture device stored within the open base space.

A cross flow ventilated compressor compartment to have two (2) stainless steel exterior frames complete with removable stainless steel louvers for service and cleaning. Interior of housing to have easy access slide-out channels to accommodate the condensing unit.

Provide countertop cutouts and case body flush-mounted convenience power outlets for countertop mounted equipment power cords or pigtails.

Tables furnished with SpecLine Quick Switch hot/cold/freeze wells are to comply with following specifications. Top perimeter of each unit is to be constructed of 14 gauge stainless steel, welded, ground and polished with a thermal break provided between the top and refrigerated interior. Interior pan

is to be 18 gauge stainless steel, fully welded, ground and polished with a 3/3" open drain. To be fully insulated with 1-1/2" to 2" urethane insulation. The exterior jacket is to be constructed of heavy gauge galvanized steel.

The refrigeration system is to be 1/3 H.P. hermetically sealed compressor operating on R-507 (HFC) refrigerant, and will include controls. New energy efficient hot food wells to use digitally controlled, 500 watt heat source. All switches and controls are fully accessible and are provided with cord and plug. Units shall bear the UL classified EPH label for sanitation meeting all NSF4 and NSF 7 requirements. Wells are to be fully capable of maintaining hot temperature, cold temperature, and frozen temperature with the turn of a switch.

Cashier's Table body interior to be lined with 18-gauge stainless steel with covered vertical and horizontal corners. Provide a removable stainless steel locking cash drawer, a 110 flush-mounted convenience outlet, a slide out stainless steel storage shelf.

Buffet shields, as required, for self-service operation, to be Plexiglas sneeze guard along side with Plexiglas end closures. A removable top cap shelf mounted over the edge of the guards to be fabricated from 16-gauge stainless steel with all sides turned down square and all corners fully welded, ground and polished. Shield to have adjustable height from 6" to 12" at 1" increment without the use of tools. All buffet shields to have factory mounted and wired fluorescent lights that are wired internally to an on-off switch located in the control panel of the table.

Food protector, as required, to be curved front food protector and shall have an 18 gauge stainless steel top serving shelf with all edges turned down square and all corners fully welded, ground and polished. Edges to have #7 H9-lite finish. Ends and curved front glass to be 1/4" Plexiglas having air space at top and bottom. All Plexiglas to be bound in stainless steel channel to prevent chipping. All food protectors to have factory mounted and wired fluorescent lights that are wired internally to an on-off switch located in the control panel of the table.

Two tier display, as required, with curved front stand shall have uprights constructed of 1-1/4" square stainless steel tubing with stainless steel cop and base. Shelves to be 1/4" polished plate glass resting on a horizontal stainless steel framework welded to the uprights. The display stand is to be enclosed on the ends with 1/4" polished plate glass curved Plexiglas on the front. Front sneeze guard to be mounted on adjustable stainless steel brackets. All tow tier display units to have factory mounted and wired fluorescent lights that are wired internally to an on off switch on the control panel of the table.

Warranty is to be five years on fiberglass bodies, two years on controllers, and one year parts and labor on all other features, by the manufacturer. Warranty period to begin after school start up and Owner demonstration training has been satisfactorily completed.

All equipment shall be listed by Underwriter's Sanitation Inc. and U.L. Sanitation Inc. and shall bear each symbol. Equipment is to be UL listed and UL certified to current ANSI/NSF sanitation standards.

Water valves and accessories shall be lead free in accordance with NSF/ANSI 372 standards.

SERVING LINE EQUIPMENT

K-1 Tray Stand:

Provide tray stand furnished in accordance with plans and specifications. 14 gauge stainless steel top, molded fiberglass body. Supply Napkin Pan, 8 silverware holders, with slanted top and line up locks. (Similar to LTI SpecLine 28-RTS-F).

K-2 Milk Cooler / Dispenser:

Provide forced air refrigerated milk cabinet having the following features: 18 gauge white coated steel exterior body panels, with stainless steel fold down door and flip-top lid, and 304 stainless steel interior.

Capacity: 12 milk crates. Electrical characteristics as scheduled, cord and plug. Self-contained, R290 cold-wall refrigeration system, with auto defrost function. Self-leveling system with each milk crate held at proper height with self-leveling mechanisms. To have 5 inch swivel casters, with locking devices, and non-marking bumpers. Exterior dial adjustable thermometer, with digital readout, lid locking assembly, and line up locks. (Similar to Avantco MC49-HC 49" School Milk Cooler).

K-3 5 Pan Unit with Counter Protector:

Provide 5 well hot food serving counter, furnished in accordance with plans and specification. Manufacturer shall provide electric hot food cabinets having the following features: Electrical characteristics as scheduled, cord and plug; unit to have solid 14 gauge stainless steel top and molded fiberglass body; unit to have bottom open storage base on servers side; color selection by Architect; unit shall individually heated wells with thermostatic controls, wired to a master switch; unit to have 1 inch copper drain with ¼ turn drain cut-off valve; unit to have an adjustable single sided buffet type sneeze guard with LED lights equal to (CCCP) CrystalClear Counter Protector; unit to be 28 inch high; unit to have a 10 inch wide beaded shelf on each side at 28 inch height. Provide 5" locking swivel castors. Unit to bank and fasten to adjacent unit (similar to LTI SpecLine SPC-D/DW-MF-20-05-74).

K-4 Cold Serving Counter with 2 tier Display DBL Service:

Provide electric frost top cold food cabinet, with the following features: Electrical characteristics as scheduled, cord and plug; unit to have solid 14 gauge stainless steel top and molded fiberglass body. One inch copper drain pipe with ¼ turn drain cut-off valve; unit to have an 2-tier display shelf, double service with LED lights; unit to be 36 inch high, with 10" wide beaded stainless steel tray slide at 28 inch height, each side; unit to have open storage base on server's side, 4-pan mechanically refrigerated cold well with thermostatic controls, wired to a master switch; 5 inch locking swivel castors; unit to bank and fasten to adjacent equipment (similar to LTI SpecLine SPC-FT-MF-25-82-84).

K-6 Solid Top Solid Top Serving Counter with 2-Tier Display, DBL Service:

Provide solid top serving counter, with 2-tier display. Unit to have 30" 14 gauge stainless steel top, 2-tier display shelf – double service, molded fiberglass FRP body, servers side open storage base, with beaded stainless steel tray slide each side at 28", with key slots to accept adjacent equipment, and 5" locking swivel castors (similar to by LTI SpecLine 50-ST-F)

K-7 Cashier Station:

Provide reinforced molded fiberglass cashier station having the following features: basic counter section with molded fiberglass counter; continuous 14 gauge stainless steel top; reinforced for rigidity, TUBULAR FOOTREST; unit to be 36 inch high, with 10" wide x 16 gauge beaded stainless steel tray slide each side at 28 inch height; 5 inch castors with locks on all wheels; table mounted 120 /1 phase outlets, pre-wired to a single junction box; locking cashier drawer, line up locks (similar to LTI SpecLine 36-CSE-F).

GENERAL KITCHEN EQUIPMENT

K-5 96 Inch Worktable with Backsplash:

Table as per specified model, 96" x 30" x 36" 14 gauge stainless steel top with 1 5/8" rolled rim front side, 1 5/8" square side edges, and 5" rear splash with 1" return, (1) 20"x20"x5" stainless steel drawer, 18 gauge stainless steel removable under shelf with adjustable leg clamps, 1 5/8" O.D. 16 ga. stainless steel legs with adjustable bullet feet (ADVANCE TABCO KSS-308).

K-8 84 Inch Worktable with Backsplash:

Table as per specified model, 84" x 30" x 36" 14 gauge stainless steel top with 1 5/8" rolled rim front side, 1 5/8" square side edges, and 5" rear splash with 1" return, 18 gauge stainless steel removable under

shelf with adjustable leg clamps, 1 5/8" O.D. 16 ga. stainless steel legs with adjustable bullet feet (ADVANCE TABCO KSS-307).

K-9 Refrigerated Cabinet Pass Through:

Provide refrigerator with top mounted air-cooled condensing unit; exterior dial thermometer, cylinder locks and top mounted condensate evaporator, R-290 refrigerant, having following features: electrical characteristics as scheduled; 2 Low E glass full-height front doors; 2 solid stainless steel rear doors, left and right hand hinges; stainless steel interior and exterior, stainless steel doors; with 5" locking castors. Provide (2) Shelving Kits #1: (9) sets of #1 type tray slides and pilasters, (1) 18"x26" pan, (2) 14"x18" pans. (similar to TRUE STR2RPT-2G-2S-HC)

K-10 Heated Cabinet Pass Through:

Provide enclosed pass-through heater cabinet having following features: electrical characteristics as scheduled, cord and plug; all welded polished stainless steel cabinet – interior and exterior, insulated; heavy-duty adjustable stainless steel wire racks – 4-pack PS2938-4; U.L. Listed, touch control temperature and humidifier control assembly; stainless steel / glass hinged pass-through dutch doors with positive latching; corner bumpers (similar to WINSTON HOV5-14UV).

K-11 Ice Machine / Bin Storage:

Provide an air cooled, modular ice cube machine with a 24 hour production capacity of 665 pounds of ice at 90°F air temperature. Machine shall utilize R-404A refrigerant. Machine shall deliver individually produced and harvested crescent shaped cubes. There shall be no moving parts under refrigeration. Evaporator shall be of stainless steel construction and produce ice on both sides of the plate. Machine is storage bin top mounted unit. UL, CUL, NSF and USDA listed. Factory stainless steel (similar to HOSHIZAKI KMD-860MAJ with Bin B-250SF).

K-12 2-Compartment Prep Sink:

Sink model as specified, 14-gauge 304 stainless steel 101" long with two 24"x24"x 14" deep compartments and drain board on each end, with 11" backsplash. Sink to be equipped with 2" lever waste on each compartment. Coordinate with K-13. (ADVANCE TABCO REGALINE 93-42-48-24RL)

K-13 Pre-Rinse Faucet Splash/Wall Mount:

Provide splash-mounted wall-braced faucet/spray hose, having following features: 12" swing spout splash-mount faucet, 44" flexible stainless steel hose, self-closing spray valve, mixing valve with integral check valves and vacuum breaker, wall bracket braced. (Similar to T&S BRASS, B-0133-A12B-TEE).

K-14 Food Waste Disposer:

Provide disposer having following features: electrical characteristics as scheduled; manual starter, waterproof start/stop switch with thermal overload, solenoid and vacuum breaker; short throat housing (similar to SALVAJOR 200-SA-ARSS).

K-15 Wire Stainless Steel Shelf / Wall Mount Brackets:

Provide 18"x72" wall mounted stainless steel wire shelving having following features: heavy duty construction; Type 304 stainless steel finish; with Super Erecta Wall Brackets - 800 lb. weight capacity; arrange as shown on plan drawings, using quantities and sizes shown. (similar to METRO SUPER ERECTA DIRECT WALL MOUNT 1872NS STAINLESS STEEL)

K-16 2 Compartment Prep Table:

Sink model as specified, 85"x24" x 16 gauge 304 stainless steel top with 8" backsplash back, front and sides rolled edges, 18 gauge stainless steel drawers, 18" wide x 12" deep sink with K-13 faucet/rinse hose (ADVANCE TABCO REGALINE 93-2-36-24RL).

K-17 Hose Reel:

Furnish and install at location shown on plans, 35' blue hot water reinforced rubber hose on stainless steel hose reel with EB-107 high flow spray valve and faucet control. Unit to be T & S No. 7132-01 wall mounted, with B-0513 concealed body mixing valve and B-0963 pressure vacuum breaker.

K-18 Work Table:

Table as per specified model, 72" x 30" x 18 gauge stainless steel top with rolled rim all sides, (2) 20"x20"x5"x 18 gauge stainless steel drawers, 18 gauge stainless steel removable under shelf, edges rolled to contour of cross rails, 1 5/8" O.D. 16 ga. stainless steel legs with adjustable bullet feet (ADVANCE TABCO US-30-72).

K-19 NOT USED

K-20 Electric Reels: BY ELECTRICAL CONTRACTOR

K-21 Trench Drain and Grate:

Fabricate per Drawing details; quartz epoxy lined concrete floor trough, covered with stainless steel grating, with FD floor drain fixture in bottom (Coordinate with Plumbing Drawings/Fixture Schedule), 3/16" x 1" flat bars set on edge with 13/16" clearance between bars; two 1/2" diameter rods wedged through bars full length, and welded to each bar.

K-22 Gas Braising Pan:

Provide open cabinet base, Natural Gas heated tilting braising pan having following features: gas and electrical characteristics as scheduled; thermostatically controlled, 10" deep pan, capacity of approximately 40 gallons; 5/8" thick stainless steel clad plate cooking surface with welded heat transfer fins, heated by gas burner/combustion chamber, electronic ignition, stainless steel finish, stainless steel open tubular adjustable legs with bullet feet; front-hinged tilt mechanism, manual tilt; furnish with T&S B-270 dual pantry water fill faucet (similar to GROEN BPM-40G / A / C2T).

K-23 6 Burner Gas Range:

Provide 33,000 BTU 6-burner gas range with 45,000 BTU oven; having following features: electrical and gas characteristics as scheduled; one-piece non-clog cast iron burners (lifetime clog free) with removable cast iron grate tops, and removable drip tray, 26" wide x 26 1/2" deep standard ovens with snap-action thermostat 175 – 550 degrees range, all oven parts enameled, 2 rack guides with one rack; stainless steel front, sides and removable shelf, set of 6" adjustable stainless steel legs; with factory installed pressure regulator. (similar to SOUTHBEND 4361D).

K-24 Equipment Table with Plate Shelf:

Provide table as per specified model, 36" x 30" x 14 gauge stainless steel top with 1" turned rims (3) sides, 18 gauge stainless steel adjustable under shelf, attached with adjustable leg clamps, with 18 gauge stainless steel plate shelf TA-963, 1 5/8" O.D. 16 ga. stainless steel legs with adjustable bullet feet (similar to ADVANCE TABCO ES-303)

K-25 Gas Double Combination Oven / Steamer:

Provide a stacked double unit, with 6" adjustable legs, gas combination oven / steamer, having the following features: gas and electrical characteristics as scheduled; ability to cook with pressureless steam, hot air, or combination of steam and hot air; low temperature convection steam; low temp cook and hold feature; unit with memory programming; variable steam exhaust condensation control; half-size stainless steel doors with no view glass, butterfly valve to regulate humidity exhaust; retractable hose reel; provide unit with stacking kit (similar to BLODGETT MODEL BCX-14G).

K-26 Kitchen Exhaust Hood:

THIS ITEM PROVIDED BY HVAC CONTRACTOR. REFER TO MECHANICAL DRAWINGS.

K-27 Wet Chemical Kitchen Fire Suppression System:

THIS ITEM PROVIDED BY HVAC CONTRACTOR. REFER TO MECHANICAL DRAWINGS.

K-28 / K-29 Combination Walk - In Cooler / Freezer:

Provide a combination walk-in cooler and walk-in freezer, combined nominal exterior size 22'-8" x 21'-6" x 8'-6 1/4" high. (Similar to KOL_PAK)

Ceiling and wall panels to entrance doors shall be in-fitting, flush design. Walk-in cooler and freezer walls, roof, and floor panels shall be modular, 4" thick, insulated with UL Class I rigid foamed-in-place rigid urethane, expanded with HCFC-22.

Insulation: Shall be 100% rigid urethane with an at temperature conductivity factor (K factor) not to exceed 0.135 BTU/HR. Overall coefficient of heat transfer (U factor) not to exceed 0.033. The R value shall be 30. Urethane is to be poured in place with a density of 2.25 pounds per cubic foot. The insulation shall be a listed urethane with a rating of no more than 25 for flame spread and 400 for smoke development. Each section shall have affixed to it a label stating the above ratings

Modular Panel Construction. All panels shall consist of interior and exterior metal skins precisely formed with steel dies and roll-form equipment. The insulation shall be "Foamed in Place" rigid urethane and when completely heat cured, shall bind tenaciously to the metal skins and form a ridged four (4) inch thick insulated panel. Panels are to have no internal wood, metal or high density urethane structural members. A flexible vinyl gasket which is also formed in place shall extend around the interior and exterior perimeter of each male edge. This gasket shall not be glued or stapled in place. Standard panels shall be manufactured in 11.5", 23" or 46" widths. Corners are to be 11.75" x 11.75" x 11.75" x 23.5" or 23.5" x 23.5" and be precisely 90 degree angles. All standard panels shall be interchangeable for ease of assembly.

Cam Locks. Can action locking devices shall be accurately and precisely positioned in the panels to assure a positive joint. Where wall panels are joined together there shall be a minimum of three (3) locking devices. A steel hexagonal wrench shall be provided to tighten panel fasteners. Stainless steel snap-in caps over the wrench holes are to be provided.

Finish: Interior and exterior wall panels are to be stucco embossed aluminum. Interior ceiling panels are to be stucco embossed white finish. Exposed exterior front is to have a 34" high Diamond Tread Aluminum kick plate, including the fronts of each door.

Floor Panels: Floor panels shall be made to support a uniformly disturbed load of 2500 lbs. per square foot, prepared for quartz epoxy flooring, matching and continuous from adjacent Kitchen quartz epoxy flooring.

Doors and Sections: The door size to be 34" x 78". Doors shall be flush mounted, and both door and leaf shall be of similar construction and finish as wall panels. A heavy duty 14 gauge "C" channel of Addison Power H Brace style construction shall be foamed in place around the entire door opening to secure hardware and prevent racking and warping. Door sections shall have a frame made of FRP material that provides both strength and durability. Freezer door shall have a single anti-condensate heater and shall be concealed behind the stainless steel edge of the door jamb on all sides to prevent condensation and frost formation. This heater shall be easily accessible for replacement or service. Door section to be field wired to surface mounted junction box on the interior door panel. Threshold plate is to be constructed of 12 gauge stainless steel and must be an integral part of the door section. A heated vent shall be provided in or adjacent to the freezer door section. Doors are to feature a vinyl gasket with a magnetic core using "Christmas Tree Type Construction" shall mate with the top edge and along both sides of the door. Each door is to have a 34" high diamond aluminum kick plate interior and exterior.

The door shall be constructed to incorporate heavy duty, molded ABS breaker strips, permanently foamed-in-place. Bottom of the door shall seal with an adjustable double sweep gasket, designed to

provide a complete seal between door, threshold, and door jamb. Door hardware to be highly polished chromium plated steel, and include a hydraulic piston driven door closer equal to Kason Performer 1345, an interior safety release, (3) heavy-duty cam lift hinges, keyed / padlock handle with bumpers. All hardware shall be attached to an extra large 1/2" thick non-conduction synthetic tapping plates. Provide door locking bars.

Each door section is to have a 2" dial thermometer, flush mounted in each door section, with a temperature range of -40 to +60 degrees F.

Equip cooler and freezer with interior temperature sensors connectivity capable to send a low temperature alarm that emits a signal to the Security System Control Panel via the Building Security System, and a data readout logger.

Each entrance door is to be provided with an incandescent vapor-proof light on the interior of the door section. The light shall have a coated shatterproof globe.

Interior side of door openings shall be fitted with a Clear-Vu clear stripless swinging door, as manufactured by CCI Industries, Inc.

A neon pilot light and toggle switch shall be flush mounted on the exterior of the door section and shall have a stainless steel cover.

The freezer compartment is to be furnished with four (4) High Efficiency Kason Model 1810ES quick-start light fixtures with fluorescent lights. The cooler compartment is to be furnished with three (3) High Efficiency Kason Model 1810 ES quick-start light fixtures with fluorescent lights. Each with low temp ballasts.

Common partition walls shall be attached to adjacent wall panels by the use of cam-action locks secured within special sections formed by those panels.

Refrigeration systems are to be provided by the walk-in manufacturer and will be designed to operate a cooler compartment 1 1/2 H.P. medium temperature system at +35 degrees F, and the freezer compartment with a 3 H.P. low temperature system at -10 degrees F. Refrigeration systems are to be pre-assembled remote complete with outdoor controls and housing and scheduled to operate on 208/60/3 voltage. The system shall be air cooled, semi-hermetic as manufactured by Copeland equivalent and be complete with outdoor controls and housings. Refrigeration systems to have R-404A refrigerant.

WARRANTY: Manufacturer shall provide a written warranty to the Owner stating that the product is free from defects of workmanship under normal use and service. All panels are to be warranted for 15 years on the panel against delamination or insulation separation. All hardware is to be warranted for a period of five (5) years. Refrigeration warranty is to be one full year with an extended refrigeration components warranty of five (5) years.

Drain Lines: Installing contractor shall provide suitable drain lines from all evaporators. Drains shall be trapped outside the walk-in. Freezer drain lines shall be heated and insulated to prevent freeze-up. All plumbing to be in accordance with local codes.

Closure Panels: Provide closure panels above the cooler/freezer to seal to the building as well as trim strips to seal to each adjoining wall. Panels and trim strips to be constructed of same material as walk-in cooler / freezer. All wall penetrations for conduit, refrigeration lines to be sealed by the installing dealer / contractor.

Sprinkler System: Where cooler or freezer is within a building protected by a sprinkler system, both the cooler or freezer and that part of the building in which it is located shall be sprinklered.

Approvals: Walk-in construction is approved by the NSF and shall have the NSF seal on the door section. Walk-in panels shall have a UL flame spread rating of 25. The door section shall be UL and CSA listed as an electrically approved assembly. Additional approval to be ISO 9001 as registered by UL.

Installation: All installation work to be conducted by a licensed Refrigeration Technician. All labor, materials, power tools, transportation, services and equipment necessary to complete the installation of a refrigerated building as shown on the drawing and specifications herein, including refrigeration, final connections, factory authorized start up with service warranty and the removal of all debris from the job site. All work to be performed in accordance to all STATE, COUNTY, and CITY Building Codes and regulations in conjunction with properly licensed Contractors.

WALK IN COMBINATION COOLER / FREEZER - KOLPAK

Compartments:

Freezer

Interior Dimensions: 20'-10" x 16'-8" x 7'-10 5/8"

Walls: 4" Class 1 - Foamed

in place Urethane **Exterior:**

Aluminum - Natural Embossed

- .040 **Interior:** Aluminum -

Natural Embossed - .040

Ceiling: 4" Class 1 - Foamed in place Urethane

Type: Standard

Attachment: Lock Down

Exterior: Galvalume - Embossed 26 Ga

Interior: Aluminum - Embossed White .040

Floor Application: 4" Class 1 - Foamed in place Urethane

Type: Standard 1000# ERA

Finish: Aluminum - Smooth Aluminum .100

Compartment Accessories:

<u>Qty</u>	<u>UoM</u>	<u>Description</u>
4	ea	Light - LED 48IN 120/230V 50/60HZ

Doors/Openings:

Door: 34" x 78" Right Swing Out
Recessed 4" with 0" Leveling Sand and 0" Tile & Grout.

Frame: **Exterior:** Aluminum - Natural Embossed - .040 Kickplate, Alum
.063 Diamond Tread 36" High

Interior: Aluminum - Natural Embossed - .040 Kickplate, Alum
.063 Diamond Tread 36" High

Plug: **Exterior:** Aluminum - Natural Embossed - .040 Kickplate, Alum

.063 Diamond Tread 36" High
Interior: Aluminum - Natural Embossed - .040 Kickplate, Alum
 .063 Diamond Tread 36" High

Door/Opening Accessories:

<u>Qty</u>	<u>UoM</u>	<u>Description</u>
1	ea	Locking Bar - Concealed (with Padlock)
1	ea	Strip Door - (Bi-Parting) 34 x 78
1	ea	Alarm - Modularm 75LC 120V 60Hz, Dry Contacts
1	ea	Vent - Pressure Relief, Heated 120V 50/60Hz 4/5/6" Thick (STD)
1	ea	Light Centered Over Door Opening
2.83	lf	Threshold, Stainless Steel 14 ga
1	ea	Heater Wire, 5 Watt / FT
3	ea	Hinge - Kason 1346 Polished Chrome Adjustable / Spring Assisted
1	ea	Door Closer - Kason 1094
1	ea	Light Fixture - Kason 1803 LED w/Bulb, Globe & Nightlight 120V 50/60Hz (STD)
1	ea	Handle – Kason 27C Polished Chrome, 1/4 Turn ISR Lockable (4" Thick)

Cooler

Interior Dimensions: 16'-8" x 16'-8" x 7'-10 5/8"

Walls: 4" Class 1 - Foamed

in place Urethane **Exterior:**

Aluminum - Natural Embossed

- .040 **Interior:** Aluminum -

Natural Embossed - .040

Ceiling: 4" Class 1 - Foamed in place Urethane

Type: Standard

Attachment: Lock Down

Exterior: Galvalume - Embossed 26 Ga

Interior: Aluminum - Embossed White .040

Floor Application: 4" Class 1 - Foamed in place Urethane

Type: Standard 1000# ERA

Finish: Aluminum - Smooth Aluminum .100

Compartment Accessories:

<u>Qty</u>	<u>UoM</u>	<u>Description</u>
------------	------------	--------------------

1	ea	Vent - Pressure Relief, Heated Kason 1832 - ALLOWED IN WALLS OR SCIENTIFIC DOORS (Ensure not behind a Masonry Wall)
99	sf	Wainscot Aluminum Diamond Tread .063 * For 36" high on exposed exterior.
3	ea	Light - LED 48IN 120/230V 50/60HZ

Refrigeration:

<u>Qty</u>	<u>UoM</u>	<u>Description</u>
1	ea	KPC99MOP-3E PC99MOP-3E, 208/230/60/3, 1 HP, R404A, Medium Temp Standard Pre-Charged Air-Cooled Hermetic Condensing Unit, Amps: 6.5, Ambient Temperature: 100 Includes Fan Cycle Controls, Amps: 6.5, Ambient Temperature: 100
1	ea	KAM26-117-1EC-PR-4 AM26-117-1EC-PR-4, 115/60/1, R404A, Medium Temp, Air Defrost, Standard Unit Cooler, Amps: 1.6 One year parts and labor included

Refrigeration Accessories:

<u>Qty</u>	<u>UoM</u>	<u>Description</u>
------------	------------	--------------------

Doors/Openings:

Door:	34" x 78" Right Swing Out Recessed 4" with 0" Leveling Sand and 0" Tile & Grout.	
Frame:	Exterior: Aluminum - Natural Embossed - .040 .063 Diamond Tread 36" High	Kickplate, Alum
	Interior: Aluminum - Natural Embossed - .040 .063 Diamond Tread 36" High	Kickplate, Alum
Plug:	Exterior: Aluminum - Natural Embossed - .040 .063 Diamond Tread 36" High	Kickplate, Alum
	Interior: Aluminum - Natural Embossed - .040 .063 Diamond Tread 36" High	Kickplate, Alum

Door/Opening Accessories:

<u>Qty</u>	<u>UoM</u>	<u>Description</u>
1	ea	Locking Bar - Concealed (with Padlock)
1	ea	Strip Door - (Bi-Parting) 34 x 78
1	ea	Alarm - Modularm 75LC 120V 60Hz, Dry Contacts
1	ea	Light Centered Over Door Opening
2.83	lf	Threshold, Stainless Steel 14 ga
3	ea	Hinge - Kason 1346 Polished Chrome Adjustable / Spring Assisted
1	ea	Door Closer - Kason 1094

1	ea	Light Fixture - Kason 1803 LED w/Bulb, Globe & Nightlight 120V 50/60Hz (STD)
1	ea	Handle – Kason 27C Polished Chrome, 1/4 Turn ISR Lockable (4" Thick)

K-30 Epoxy Wire Shelving:

Provide dark green epoxy-coated wire shelving having following features: heavy-duty construction; epoxy-coated finish; each unit has four uprights with adjustable feet; two-shelf clips per unit for rigidity; uprights shall not exceed 75 inch high, including adjustable feet, four tier shelving; arrange as shown on plan drawings, using quantities and sizes shown. (similar to METRO SUPER ERECTA - METROSEAL 3, EZ2448NK3-4)

K-31 Dunnage Flats:

Provide bow-tie dunnage racks, 22" wide x 48" long x 12" high, fabricated with rust and corrosion proof polymer material, racks joined together with bowtie key, 3,000 lb. capacity; count (LOT) as shown on drawings (similar to METRO BOW-TIE POLYMER DUNNAGE RACKS HP2248PD).

K-32 Aluminum Can Rack:

Provide aluminum frame can storage rack for #10 cans storage, 1 1/2" tubular aluminum frame, with angled can guides, holds (162) #10 cans or (216) #5 cans. Count (LOT) as shown on drawings (similar to STEELTON CNRK162KD).

K-33 Residential Clothes Washer:

THIS ITEM PROVIDED UNDER RESIDENTIAL APPLIANCES ALLOWANCE. See specification 11450 AND 01056 for more information.

K-34 Residential Clothes Dryer:

THIS ITEM PROVIDED UNDER RESIDENTIAL APPLIANCES ALLOWANCE. See specification 11450 AND 01056 for more information.

K-35 Refrigerator:

Provide reach-in solid half swing door refrigerator with self-contained refrigeration and polyurethane insulation; exterior dial thermometer, cylinder locks and bottom mounted epoxy coated condensate evaporator, R-290 refrigerant, having following features: electrical characteristics as scheduled; 4 solid half-height front doors; left and right hand hinges; stainless steel and aluminum interior and exterior, 6 adjustable heavy-duty PVC coated wire shelves, stainless steel exterior door with aluminum interior liners; with 5" locking castors. (similar to TRUE T-49-4-HC)

K-36 Utility Cart:

Provide heavy duty molded polyethylene exterior, 500 lb. capacity, manufactured in accordance with plans and specifications; 5" castors, 2 fixed, 2 swivel, 1 with brake (similar to CAMBRO BC235).

K-37 Three Compartment Sink / Dish Table:

Table and sink as per specified model; 151" x 32". Provide stainless steel clean and dirty dish tables, with integral 3-compartment sink, and 9" backsplash. Provide slatted stainless steel shelving below clean table. Sink to be furnished with (2) K-39 chrome plated backsplash mounted mixing faucets with aerators for 8" center set, 12" swing spouts, T&S B-0231. Sink to be equipped with K-38 booster heater as shown on plans. Sink bowls to be equipped with 2" lever waste on each compartment. (ADVANCE TABCO REGALINE 93-43-72-36RL)

K-38 Soup Kettle Warmer:

Provide black soup kettle warmer, 16"x16"x 120 V, dishwasher safe removable lid and inset. Stew and soup labels. (similar to AVANTCO S600 14 QT)

K-39 Swing Spout Splash Mount:

Provide chrome plated backsplash mounted mixing faucet with aerator for 8" center set, 12" swing spout. (similar to T&S B-0231)

K-40 Caster Cart 4 Shelf with Cover:

Provide Stem Caster cart with 4 adjustable shelves, in chrome finish, (4) rubber casters, (2) castors with brakes. Provide Metro ESD Cart Cover with slip resistant texture, flame retardant, flap and zipper closure, and paperwork document pouch. (similar to METRO 4-TIER STEM CASTER CART A536BC)

K-41 Dishwasher with Extended Stainless Steel Vents to Ceiling:

Provide high temperature rack conveyor dishwashing machine, electric tank heat model, Energy Star Certified, having the following features: electrical characteristics as scheduled; 90-gallons per hour pumped final rinse, manufacturer's stainless steel finish, stainless steel base and frame, and stainless steel adjustable bullet feet; stainless steel closure panels; built-in internal booster heater, auto tank fill, anti-clog wash/rinse arms, extended stainless steel vent hoods, touchscreen controls with WIFI connectivity. (similar to HOBART CL66-ADV)

K-42 Dish Return Table with Pre-Wash:

Provide stainless steel dish return table fabricated per drawing details, with pre-rinse sink / K-14 Disposal and K-13 faucet/rinse hose, as per drawings.

K-43 Tray Return Window:

Provide stainless steel shutter with push up operation, all stainless steel construction (similar to Cookson CD10-1SS).

K-44 One Compartment Sink: (ONE FOR MAKERSPACE)

Provide 60" long x 28" x 34" high, 16 gauge 304 stainless steel all TIG welded sink with integral 36" drainboard, with 12" deep bowl and 8" backsplash, adjustable side cross braces featuring leg clamps, with splash mounted K-39 swing spout faucet. Featuring adjustable bullet feet, drainboard right and left configurations as per drawings. (similar to ADVANCE TABCO REGALINE 93-41-24-36L)

K-45 2-Compartment Sink: (ONE FOR ART CLASSROOM)

Sink to be fabricated per drawing details. Provide 16 gauge stainless steel sink, 101" long x 30" x 34" high, with two 24"x24"x 12" deep compartments and integral drain boards configured as per drawings, with 8" backsplash. Sink to be equipped with K-39 chrome plated splash mounted 12" swing spout mixing faucets, and plaster traps as per Plumbing requirements. Provide slatted stainless steel shelving below table. Sink bowls to be equipped with 2" lever waste on each compartment. Coordinate locations with drawings and Plumbing requirements. (similar to ADVANCE TABCO REGALINE 93-42-48-24L)

END OF SECTION

RELATED DOCUMENTS:

Drawings and general provisions of Contract, including General and Supplementary Conditions and Division-1 Specification sections, apply to work of this section.

GENERAL:

The Contractor shall provide residential kitchen appliances with Cash Allowance specified Section 01056 including tax, for the purchase and installation of residential kitchen appliances for those areas indicated. These items are in addition and not related to the residential kitchen appliances scheduled for the Foods Lab 523.

Types of residential equipment required may include, but are not necessarily limited to the following:

- Upright Refrigerator/Freezers
- Undercounter Refrigerators
- NSF Rated Commercial Microwaves
- Stack Washer / Dryers
- Clothes Washers
- Electric Clothes Dryers; provide clothes dryer model with a "Long Vent" LV option for dryer vent system as a required feature, with minimum of 120 ft. to 160 ft. allowable length of dryer vent.

Color: Stainless Steel

Certification Labels: Provide residential equipment, which complies with standards and bears certification labels as follows:

Energy Ratings: Energy Star rated. Provide energy guide labels with energy cost analysis (annual operating costs) and energy information as required by Federal Trade Commission.

UL Standards: Provide residential equipment with UL Labels.

PRODUCT WARRANTIES:

Submit manufacturer's standard written warranty for each item of residential equipment.

END OF SECTION

RELATED DOCUMENTS:

The general provisions of the Contract, including General and Supplementary Conditions, and General Requirements, apply to the work specified in this section.

PART 1: GENERAL

DESCRIPTION OF WORK:

Projection systems, flat screen video display monitors and mounting brackets/hardware shall be provided under the cash allowance listed in Section 01056. Provide mechanical mounting brackets designed to support the video display monitors, where indicated on Drawings and specified in this Section.

Projection Systems (installed): Provide where indicated in the Drawings. After final purchase approval from Owner, purchase projection systems with hardware and mounting brackets, installed with the cash allowance under Section 01056 Allowances.

Video Display Monitors (installed): Provide where indicated in the Drawings. After final purchase approval from Owner, purchase video monitors with mounting brackets and install with the cash allowance under Section 01056 Allowances.

INDUSTRY STANDARDS:

For listing of names of industry standard agencies mentioned by abbreviation in this Section, refer to Section 01068.

QUALITY ASSURANCE:

Manufacturers:

Video Display Mounting Brackets Standard: For purpose of designating type and quality for work under this Section, Drawings and Specifications are based on Sanus VisionMount products manufactured by Sanus Systems (800) 359-5520. Other Manufacturers who can furnish products or systems of same materials specified and equal in all respects will also be acceptable, such as Da-Lite, and Peerless.

WARRANTY:

The mounting bracket used shall be supplied with a warranty against defects in workmanship and materials for five (5) years.

SUBMITTALS:

Manufacturer's Data: Submit five (5) copies of folder containing complete Manufacturer's data and installation procedures for all products to be used in work of this Section.

Shop Drawings: Submit Shop Drawings in compliance with GENERAL CONDITIONS. These drawings shall be coordinated with adjacent work.

PRODUCT HANDLING:

Working Areas: Provide suitable areas for storage of materials and equipment.

Delivery: Deliver products to site in original sealed containers or packages bearing Manufacturer's name and brand designation.

PART 2: PRODUCTS (final total list of equipment to be final approved by the Owner)

FLAT SCREEN VIDEO DISPLAY MONITOR MOUNTING BRACKETS: (provide under 01056 allowance)

The flat screen video display monitor wall bracket shall be Sanus Systems Premium Series Tilt-Mount Wall Mount, Model VLT5 (for 42" to 90" flat screens), or equivalent. Model shall be coordinated with the VDM video display monitors. Load capacity: 175 lbs. Tilt-mount screen adjustment capable. UL listed. Provide with security device: horizontal lock bar mechanism for padlock. Provide a universal fastener pack of all necessary screen attachment hardware, with mounting capabilities to wood studs/gypsum wallboard, concrete, CMU block, or metal studs/gypsum wallboard. Provide all necessary accessories for a complete installation and operable assembly.

The TV/Monitor wall bracket assemblies shall be of sufficient strength to support the weight of the flat screen Video Display Monitor for which is designed, with an adequate safety factor. It shall be installed with a wall attachment device capable of supporting the weight of the Video Display Monitor, the bracket itself. Confirm and coordinate bracket capabilities with the video display monitor size and weight. The video display monitor bracket shall wall mount and hold flat screen TV 1.25" from wall. Bracket shall be adjustable in both height and width to ensure proper fit. A locking mechanism shall hold TV securely in position.

Materials: Construction of the bracket shall be of heavy gauge steel with MIG welds, in scratch-resistant Satin Black powder coated finish.

PART 3: EXECUTION

INSPECTION

Examine all surfaces to which products are scheduled to be installed. If unsatisfactory conditions exist, report to General Contractor and do not proceed with work until conditions have been satisfactorily corrected.

INSTALLATION

Brackets for Video Display Monitors shall be installed where indicated on the plans. All fasteners and components for complete assembly of the bracket shall be furnished by the manufacturers.

Provide wood wall blocking for drywall wall mounted brackets. Reference Section 06100 Rough Carpentry for wall blocking requirements.

All CMU wall brackets to be through bolted through walls with plates, nuts and washers.

Install in accordance with Manufacturer's printed instructions and Shop Drawings, approved by Architect.

All installations shall be performed by capable workmen under direction of foreman fully qualified by experience in each respective field of installation work.

END OF SECTION

SECTION 13900 - WET PIPE SPRINKLER SYSTEMS

PART I - GENERAL

1.1 RELATED DOCUMENTS

- A. Drawings and General Provisions of the Contract, including General and Supplementary Conditions and Division 1 Specification Sections, and North Carolina for Automatic Sprinkler Systems, apply to this Section.

1.2 SUMMARY

- A. This Section provides the basic information needed to design and install a Wet-Pipe Sprinkler System for the project building.

1.3 SYSTEM DESCRIPTION

- A. System to provide coverage for the entire new addition or building. See plans for areas as indicated to be sprinkled.
- B. Coordinate with Elec. Contractor for sprinkler system interface requirements with building 120V power, and fire/smoke alarm system.
- C. Provide system to NFPA 13 Light or Ordinary hazard, Group 1 occupancy or as required for the type occupancy if other than Light/Ordinary hazard. See architectural plans for occupancy and construction types.
- D. Provide Fire Department connections as indicated. See Civil – Site plans and coordinate with local Fire Official for proper FDC type (Siamese or Storz) and preferred location prior to bid.

1.4 SYSTEM PERFORMANCE AND DESIGN REQUIREMENTS

- A. Wet pipe sprinkler subcontractor is fully responsible for the design of a complete and compliant system, certified by an North Carolina Professional Engineer or registered NICET Level III Sprinkler Designer, and responsible to obtain approval from authorities having jurisdiction for the Fire Protection Systems specified. Storage tank size, pump size, and main line sizes are indicated as basis of bid only. Subsequent to award of contract, Sprinkler contractor shall perform all necessary investigative hydraulic work and final costs / sizes of the aforementioned will be adjusted with cost credits or adds in accordance with the general and supplemental conditions of the contracts.

The Sprinkler contractor is responsible for providing the main line piping to the site contractor for installation. The Site Contractor shall install the main line piping. All parts, pieces, assemblies, and items for a complete and compliant system shall be provided.

- B. Contact local utilities for fire hydrant flow tests results, as required to prepare design for hydraulically calculated systems.
- C. Design installation to conform to NFPA 13, N.C. State Building Codes, and the latest issue of the "Requirements for Automatic Sprinkler Systems" and all subsequent Amendments to date, as published by the North Carolina Department of Insurance.
- D. Designer is responsible for reviewing information on the plans and verifying, adjusting, or

correcting sizes as necessary to meet NFPA 13 requirements and flow rates at the actual pressures available from the local utility lines at no additional cost to the contract.

1.5 SPECIAL CONDITIONS

- A. Horizontal sprinkler mains and branches shall be located as high as possible above the ceiling and heads dropped down into ceiling where ceilings are indicated on architectural reflected ceiling plans..
- B. All horizontal sprinkler pipes shall be located above the finished ceiling. If the ceiling is higher than the specified mounting height then provide the required risers and offsets to locate the pipe above the ceiling.

1.6 QUALITY ASSURANCE

- A. Manufacturer Qualifications: Firms whose equipment, specialties, and accessories are listed by product name and manufacturer in UL Fire Protection Equipment Directory and FM Approval Guide and that conform to other requirements indicated.
- B. Listing/Approval Stamp, Label, or Other Marking: On equipment, specialties, and accessories made to specified standards.
- C. Comply with requirements of authority having jurisdiction for submittals, approvals, materials, hose threads, installation, inspections and testing.
- D. Installer's Qualifications: Firms qualified to install and alter fire protection piping, equipment, specialties, and accessories, and repair and service equipment. A qualified firm is one that is experienced (minimum of 10 previous projects similar in size and scope to this Project) in such work, familiar with precautions required, and in compliance with the requirements of the authority having jurisdiction. Submit evidence of qualifications to the Architect upon request.

1.7 SUBMITTALS

- A. Submit shop drawings and product data that includes detailed pipe layout, hangers and supports, components and accessories.
- B. Submit shop drawings and hydraulic calculations to authority having jurisdiction and Architect/Engineer for approval. Submit Proof of Approval to Architect/Engineer.

1.8 OPERATION AND MAINTENANCE DATA

- A. Submit manufacturer's Operation and Maintenance Data.
- B. Include written Maintenance Data on components of system, Servicing requirements and Record Drawings.

1.9 DELIVERY, STORAGE AND HANDLING

- A. Provide temporary inlet and outlet caps.
- B. Maintain caps in place until installation.

1.10 EXTRA STOCK

- A. Provide extra sprinkler heads under provisions of NFPA 13.

- B. Provide suitable wrenches for each head type.
- C. Provide metal storage cabinet in location designated.

PART II - PRODUCTS

2.1 ACCEPTABLE MANUFACTURERS

- A. Central Sprinkler Corporation
- B. Star Sprinkler Corporation
- C. Viking Corporation

2.2 PIPING MATERIALS

- A. Buried Piping: Ductile iron, Class 50
- B. Above Ground Inside Building Piping: Steel, Schedule 10 black. Schedule 5 or thin wall threadable pipe is not acceptable.
- C. Woven mesh stainless steel flexible hose is acceptable for drops to individual sprinkler heads.

2.3 PIPING SPECIALTIES

- A. Automatic Sprinkler Valve: Flow detector with alarm circuits, pressure switch, pressure retard chamber.
- B. Alarm Gong: Electric type, see Fire Alarm plans.
- C. Fire Department Connection: Wall type; chrome plated finish; thread size to suit fire department hardware; two way threaded dust cap and chain of same material and finish, identification plate to match finish, indicating "AUTO SPKR".

2.4 SPRINKLER HEADS

- A. Suspended Ceiling Type: Standard recessed pendant type with chrome plated finish and the matching escutcheon.
- B. Exposed Area Type: Standard upright type
- C. Sidewall Type: Recessed chrome plated finish with matching escutcheon.
- D. Fusible Link: Temperature rated for specific area hazard.

PART III - EXECUTION

3.1 WATER SUPPLY CONNECTION

- A. Connect fire protection piping to water service piping of size and in location indicated on drawings.

3.2 PREPARATION

- A. Coordinate all work with other trades.
- B. Refer to Architectural Plans for ceiling heights and types.

3.3 INSTALLATION

- A. Install sprinkler piping in accordance NFPA 13.
- B. Install sprinkler piping with drains for complete system drainage.
- C. Provide hangers and supports in accordance with NFPA 13.
- D. Install specialty sprinkler fittings according to manufacturer's written instructions.
- E. Provide alarm devices for connection, by others, to fire alarm system.
- F. Locate Fire Department connection as indicated on Drawing. Provide sufficient clearance from walls, obstructions, or adjacent Siamese connectors to allow full swing of Fire Department wrench handle.
- G. Locate outside alarm gong on building wall.
- H. Place pipe runs to minimize obstruction to other work.
- I. Place piping in concealed spaces above finished ceilings.
- J. Center heads in two directions in ceiling tile and provide piping offsets as required.

3.4 SYSTEM TESTS

- A. Hydrostatically test entire System.
- B. Test shall be witnessed by authority having jurisdiction.

3.5 FIELD QUALITY CONTROL

- A. Flush, test and inspect sprinkler piping systems according to NFPA 13 Chapter "System Acceptance".
- B. Replace piping system components that do not pass test procedures specified, then re-test to demonstrate compliance. Repeat procedure until satisfactory results are obtained.

3.6 CLEANING

- A. Clean dirt and debris from sprinklers.

3.7 DEMONSTRATION

- A. Demonstrate equipment, specialties and accessories. Review Operating and Maintenance information.

END OF SECTION 13900